



ZYGGOT ONLINE THERMOGRAPHY

ONLINE THERMOGRAPHY - CONTINUOUS TEMPERATURE MONITORING

ETHERNET

ZYGGOT V5F ONLINE THERMOGRAPHY SYSTEM

CONTINUOUS TEMPERATURE MONITORING PROTECTION SYSTEM



CONTACTLESS ONLINE THERMOGRAPHY SYSTEM
FOR LOW AND MEDIUM VOLTAGE APPLICATIONS

MANUAL

World's First Online Thermography System (2004).
World Leader in Continuous Temperature Monitoring.
World's First UV Arc Protection System*.
Over 1 Million Sensors Installed Worldwide.
* Patent Letter No. PI 0903809-4

MANUAL ZYGGOT V5F V2.0 BUILD 158 ENGLISH May 2025

varixx

INDEX

DESCRIPTION	3
KEY POINTS	4
TECHNOLOGY AND TECHNICAL DETAILS	5
CAPTURING THE TEMPERATURE MEASUREMENT AND INFLUENCE OF EMISSIVITY	6
CAPTURING THE TEMPERATURE MEASUREMENT AND COMPOSITION OF THE PRODUCT	7
PRODUCT COMPOSITION	8
ACCESSORIES AND REPLACEMENTS	9
DETAIL OF THE INTERFACE V5CON	10
MEASUREMENT AREA, EMISSIVITY, MEASUREMENT ANGLES	11
ONE-WIRE DIAGRAM AND MAIN CHARACTERISTICS	12
PROTECTIONS AND EMISSIVITY COMPENSATION WITH UNIDEX TAPE	13
TYPICAL CONNECTIONS	14
CONNECTIONS	15
TYPICAL INTERLINKS	16
MECHANICS	18
TECHNICAL CHARACTERISTICS	19
TECHNICAL SPECIFICATIONS	20
MAIN SCREENS FOR OPERATION	21
PROGRAMMING	37
TESTING THE ETHERNET CONNECTION	57
OPERATION	58
SCREEN FLOW	60
REPORT	65
PROGRAMMING - PROGRAMMING MENU 1/2	68
PROGRAMMING - PROGRAMMING MENU 2/2	69
COMPUTER PARAMETERIZATION - ZYGGOT SUPERGER	70
SENSOR CONFIGURATION	74
FAIL SAFE SYSTEM	76
HOW TO MAKE	77
SUPERVISORY SOFTWARE	79
MODBUS	82
MODBUS - MEMORY MAP	92
THM SENSORS NETWORK MODBUS SPEC	96
MODBUS OVER ETHERNET TCP IP SERVER	97
BT SENSOR TEST REPORT	106
ABOUT VARIXX	108

Note: This manual is written in English and the same manual is also available on the website Varixx.com and Varixx.com.br in Portuguese (PT-BR). The Zyggot relay leaves the factory with 3 selectable languages, English, Portuguese and Spanish, and can also be supplied with other languages, upon request.

ZYGGOT THERMOGRAPHY TEMPERATURE MONITORING SYSTEM



VZX V5F Relay

Tubular Sensor



BT Sensor



DESCRIPTION

The low-cost ZYGGOT system was designed to allow “online” monitoring of temperatures of low and medium voltage components and internal connections, transformers, motors, etc. The ZYGGOT system introduces an important innovation in the market as the current new safety regulations prohibit the opening of energized electrical panels for any type of measurement, including temperature measurements with manual point measurement guns or thermography cameras.

The ZYGGOT system allows to monitor temperatures “On Line”, both selected targets and of the air surrounding the sensor.

An important feature is the measurement of both the target and the sensor body at the same time, which is equal to the temperature of the surrounding air.

This same characteristics also allows detecting the internal temperature rise of the panel, which can identify obstruction or ventilation failure or even temperature rise of equipment not directly monitored.

Sensors with opening angles of 7°, (other angles, on request) allow monitoring both well-defined points and areas of any dimension depending on the distance from the sensor to the area.

Each sensor has an LED that flashes on command from the relay to facilitate diagnosis and check the address. Different Alarm and Trip levels allow optimizing the protection system. Each relay can monitor up to 125 sensors. The Relay automatically indicates sensors not responding.

The data transmission method between sensors and relay uses RS-485 physical layer communication, with all sensors connected in parallel using shielded cables with mini-USB connectors that allow quick installation and operation without the need for any tools.

The Zyggot Temperature system relay can be connected to a communication network with a supervisory system or remote monitoring.

The ZYGGOT Relay has Ethernet communication with several protocols, and can be accessed from anywhere by mobile devices or not.

Note: Optionally available with Zyggot Arc Voltage protection system integrated in the same unit, saving space in the panel door and improving the interaction between the two protection systems.

APPLICATION

Temperature monitoring and “On Line” protection of electrical connections and components for low and medium voltage electrical panels, transformers, motors, brakes, processes, etc.

BENEFITS

- * Prevents opening of the energized panel.
- * Periodic thermography is not required.
- * Provides target and indoor air readings.
- * Non-contact measurement.
- * Indicates possible sensor failure.
- * Failure history.

System Features with Tubular or BT Sensors

- * Applicable in low (BT or Tubular) and medium voltage (Tubular).
- * RS485 network with mini USB connections.
- * Smart Sensors powered by the network itself.
- * Measuring angle of 7° (15° and 60° consult).
- * Continuous readings.
- * Relays with touch screen color graphic display with Modbus RTU and Ethernet communication.
- * Fault history with “Time Stamp”.
- * Reading and over- temperature protection of up to 125 points (targets) or areas.
- * Reading and over-temperature protection of up to 125 air temperature points (sensor body).
- * Reading and protection of up to 125 sensor supply voltage (network supplied).
- * Readings and protections related to 4 analog inputs.
- * External fault monitoring.
- * Monitoring of sensor states.
- * 4 + 8 programmable digital inputs.
- * 4 + 8 programmable digital outputs.
- * Each sensor has an LED that flashes and can be controlled by the relay to facilitate its location and address on the network.
- * «Fail Safe» mode operation.
- * Optionally with Zyggot Arco system integrated in the same unit (Model FTA THM+ARC).
- * **Protocols:**
- MODBUS RTU:** Modbus by serial communication.
- TCP/IP (Modbus Slave):** Modbus over Ethernet).
- FTP:** (File Server) File Transfer Protocol.
- NTP Protocol:** Network Time Protocol

MAIN ADVANTAGES

- TESTABLE WITH SYSTEM OFF
- WITH ETHERNET
- AVOID OPENING THE PANEL
- AVOID CONVENTIONAL THERMOGRAPHY
- EASY INSTALLATION-125 SENSORS P/ RELAY
- MEASUREMENT W/O ELECTRICAL CONTACT
- DOES NOT USE BATTERIES
- INDIRECTLY MEASURES THE WHOLE SYSTEM (AIR)
- PROVEN RELIABILITY
- EVENT HISTORY
- TEMPERATURE PLOT
- WORLD LEADING SYSTEM

The ZYGGOT system with tubular sensors was developed for low and medium voltage panels. The sensors measure temperature, without physical contact, by infrared detection and allow local and online reading and protection for up to 125 points per relay. Each sensor measures two levels of temperature: from the target and from the air surrounding the sensor (case) allowing detection of failures in unmeasured points, by indirect heating of the air. They are networked using mini USB cables, in sizes from 0.3 to 8.0 meters (supplied), allowing for quick, error-free and tool-free installation. The relay provides protection locally and also through a supervisory system. Alarm

KEY POINTS

- * Color Touch Screen.
- * Has Ethernet communication with several protocols.
- * Several built-in protections.
- * Real-time graphical recording (Plot).
- * History of failures and events.
- * Continuous readings of target and surrounding air temperatures.
- * Modbus RTU and Ethernet communication.
- * Each relay presents up to 375 continuous measurements, namely: Temperature of 125 targets, Temperature of 125 sensor bodies (surrounding air), voltage of 125 temperature sensors (allowing monitoring of network integrity).
- * Avoids opening of energized panel for possible thermography.
- * Indirectly monitors undefined points, by increasing the temperature of the surrounding air.

and trip levels are freely programmable for each point. An eventual failure in one of the sensors does not interrupt the operation of the other sensors. The BT Sensor is applied in low voltage MCCs, which require a high number of sensors in a small space, in addition to demanding a low cost. Its quick fixing base can be fixed by means of a screw or by means of a stainless steel fix tape directly on the bus to be monitored.

APPLICATIONS

- Internally to panels, to avoid opening for periodic thermographs.
- Supervision of Transformers.
- Engine Supervision.
- Brake supervision.
- Non-contact process supervision.

MAIN FEATURES

- Reads temperature of up to 125 targets per relay.
- Reads temperature of up to 125 sensors (body / surrounding air, allowing detection of temperature increase in points not directly monitored).
- Reads net supply voltage of up to 125 sensors.
- Configurable alarm and trip levels for temperature and analog inputs.
- Real-time graphic record for temperatures and analog inputs.
- Detection of differential temperature increase integrated into the relay and configurable by the user.
- Fault history and status.
- Continuous readings.
- 4 analog inputs with configurable alarm and trip levels.
- 4 + 8 digital inputs for external events or faults (ventilation, doors, etc.).
- 4 + 8 configurable digital outputs.
- Modbus RTU + Ethernet TCP IP. (All data accessible via Ethernet)

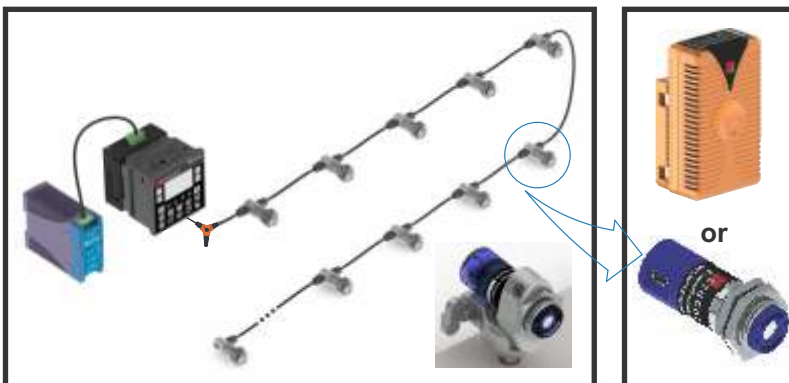

HOW TO ENSURE ACCURATE READINGS IN BODIES OF LOW OR UNKNOWN EMISSIVITY.

For low emissivity bodies, such as polished copper, which has an emissivity of 0.06, it would be very difficult to get an accurate reading. This is not a problem for the Zyggot system, as once the Unidex tape is pasted over the area to be measured, the emissivity of the area becomes constant at 0.95. This index, once introduced in the relay memory, becomes the correction index for the measured temperature, also avoiding variations with time, which could occur with oxidation, which would increase the emissivity index. Unidex tape on the other hand is stable, not changing over time.

If all areas of interest, whether material, copper, porcelain, PVC, etc., have the reading area covered with Unidex tape, it is easy to see that at the startup of the equipment, before putting it into operation, it is possible to leave it fully calibrated, it is enough to program all the emissivity indices for the value of the Unidex tape and it is not necessary to calibrate different indices for each material.

On the other hand, low cost portable meters or even some high cost ones do not have the possibility to calibrate the emissivity index, being it fixed at 0.95, leading to dubious measurements. As the Zyggot system allows calibration for each target, even without the use of Unidex tape you can have reliable measurements.

ZYGGOT VVX V5F.

- **Entradas Digitais:** 04 in the relay + 8 in the eBlock module.
- **Digital Outputs:** 04 in the relay + 8 in the eBlock module.
- **Programming of parameters and values:** "On line".
- **Reading of Values:** Temperature of each target, Temperature of each sensor body (surrounding air), Supply voltage of each THM sensor, Analog inputs.
- **Communication:** Serial RS232C and RS485 MODBUS RTU protocol for "Point to Point" connection, for use in network (Droop Out). CAN port with optional Devicenet protocol.
- **Protections and Indications:** Alarm due to target over-temperature, Trip due to target over-temperature, Alarm due to differential heating of targets, Communication failure with the THM sensor network, Modbus communication failure, THM sensors not responding, Alarm due to over-temperature of sensor body (surrounding air), Trip due to over-temperature of sensor body (surrounding air), Alarm and Trip for up to 5 groups of independent sensors, Alarm and Trip due to external failure, Alarm and trip due to analog input levels, Alarm due to memory card failure, Active alarm screens, History screen with "Time Stamp", Bargraph with sensors being read, Alarm and trip statistics, Digital input and digital output status, Analog input levels, Temperature plot for each sensor and analog input, Indication of Temperature Differential and Percentage of each sensor in relation to programmable time. Sensor voltage out of acceptable range.
- **Fault actions:** Programmable for each fault in "None", "Log", "Alarm", "Trip".
- **Real-time clock:** Included.
- **Fault history:** with date and time.
- **Event storage:** Unlimited events, stored indefinitely until cleared with a password, for security.
- **Fail Safe System:** Yes
- **Memory Card:** Automatic and manual recording of temperature reading data on the memory card for transfer to computers.
- **Active screens:** over 200 multiple screens.
- **Parameter programming:** By the relay itself, with passwords, by PC software (Free), by replication via the memory card (program one and replicate it in all relays in the system) or by Modbus (optional).
- **Multi System:** Also available in the THM+ARC version, which integrates monitoring and protection against ultraviolet arc flash and can work with up to 40 arc Gateways, each with up to 100 arc sensors.

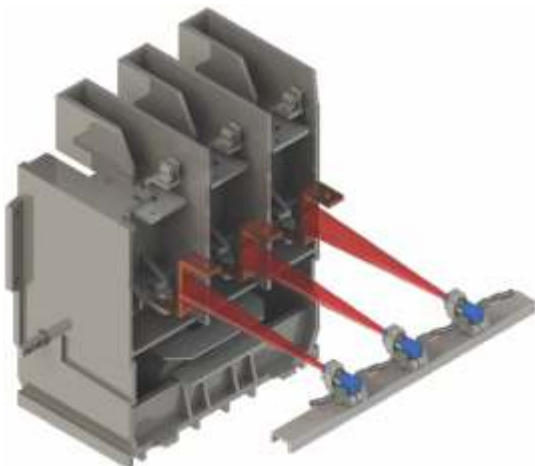

CAPTURING THE TEMPERATURE MEASUREMENT AND INFLUENCE OF EMISSIVITY

Every object with a temperature above absolute zero radiates electromagnetic energy. This radiation in the infrared range is not visible, as can be seen in the figure below.

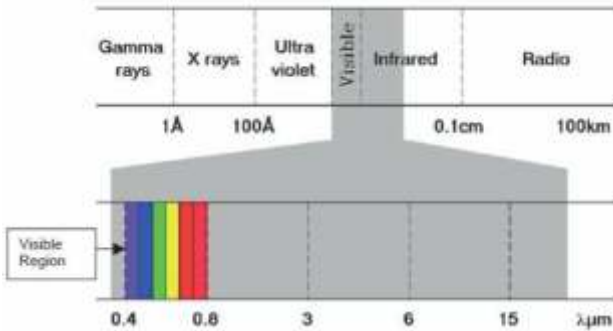

When radiation from one object reaches another object, some of the energy is absorbed, some is reflected, and if the body is not opaque, a portion is transmitted. The sum of the parts must always be equal to the total value that fell on the object. In view of these facts, in order to capture the temperature of desired targets, you must have sensors that capture such electromagnetic energy.

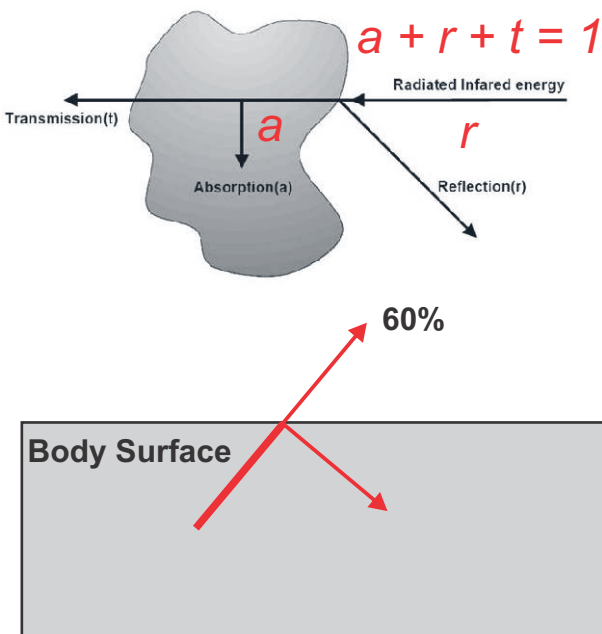

When a material is heated, its surface does not absorb all the energy and ends up emitting infrared energy. In practice, there is no material that is an ideal emitter of infrared radiation. The ideal emitter is called a black body. Objects tend to radiate less energy than black bodies even though they are at the same temperature.

The emissivity of an object is defined by: $\epsilon = t/b$

ϵ = Emissivity;

t = Radiation emitted at a certain temperature;

b = Radiation emitted by a black body at the same temperature

The table below shows the emissivity range for various materials.

MATERIAL	EMISSIVIDADE (1μm)
Iron and Steel	0,35
Iron and oxidized steel	0,85
Aluminum	0,13
Oxidized Aluminum	0,40
Polished copper	0,06
Oxidized copper	0,80
Brick	0,80
Asphalt	0,85
Asbestos	0,90

There are some portable meters that do not have the possibility of varying the emissivity index, which leads to erroneous measurements since this index is fixed at 0.95. Zyggot sensors allow emissivity index configuration, ensuring accurate measurements on any material

UNIDEX TAPE Solution for emissivity variations

Most metals have a change in emissivity due to oxidation. An example is copper, which under normal conditions has an emissivity of 0.06 and 0.80 when oxidized.

To avoid emissivity calibration readjustments of the sensors, the Zyggot System includes the supply of a special adhesive tape for temperatures up to 250°C, whose emissivity value of 0.95 is known and guaranteed by Varixx. With the Unidex tape glued over the measurement area of a target to be measured, we will always obtain the real temperature reading, without having to worry about the emissivity of the material.

Using the tape, it is not necessary to calibrate different indexes for each material.

The tape is supplied in dimensions of 50mm x 50mm or in a roll of 30m. For each sensor purchased by the customer, a tape drive is shipped.



UNIDEX TAPE ROLL (30 meters)



units de UNIDEX TAPE 50m x 50m (ref. Zu50)

TEMPERATURE MEASUREMENT AND PRODUCT COMPOSITION

POSITIONING OF SENSORS AND TEMPERATURE READING

Each sensor measures both the target's temperature and body (air) temperature at the same time.

For the correct positioning of the sensors in the pre-defined configuration area the laser is aimed at the front of the sensor and the laser light is directed to the center of the area, as shown in the figure.

A positioning area must be defined on the desired target, having the diameter of the area defined by the sensor distance. The distance between a setup area and the sensor is a maximum of 8 times the setup area diameter value for 7° sensors. The maximum indicated distance to the target must be less than 2 meters. With the distance between the sensor and the target defined, you must enter the distance parameter in the sensor using the configuration software, which is better explained later on.

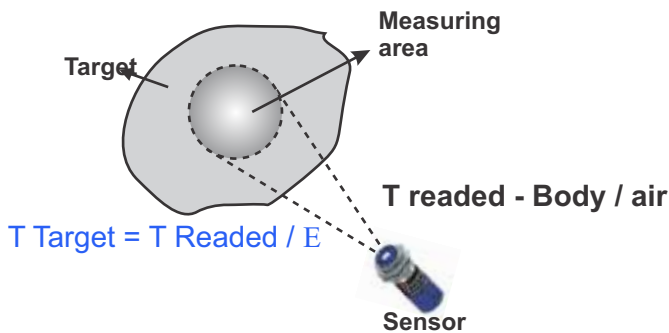

SIGHT ANGLE

Sight angle is the angle between the perpendicular of the target area and the axis that crosses the sensor longitudinally.

The curve below shows that the emissivity would only begin to decrease after an angle of 55° in relation to the perpendicular of the measured object. It is recommended to use a maximum viewing angle of 45°

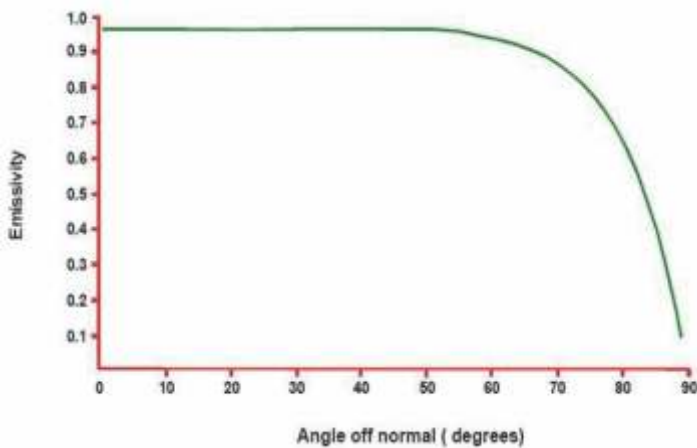

Power supply

The Zyggot Tube Temperature System must be powered from an external source. The VPS12024 source is capable of supplying the 24 VDC needed to power the relay and sensors.

Input: 90~132 / 180~264 VCA // 120~375 VCC

Output: 24VCC/5A- 120W

ZTA Derivator

The ZTA derivator (T connector) makes it possible to enable various types of topologies and layouts, facilitating the installation of the system. For more information, see pages 9, 10 and 11.

Mini USB Cables

mini USB cable

The mini USB cable performs the communication between sensors and sensors/relay.

Cables are available in the following sizes:

0,3m - ZCB/4/2U/030

0,5m - ZCB/4/2U/050

1,0m - ZCB/4/2U/100

2,0m - ZCB/4/2U/200

4,0m - ZCB/4/2U/400

6,0m - ZCB/4/2U/600

8,0m - ZCB/4/2U/800

INSTALLATION AND MAINTENANCE CASE

The Zyggot Temperature Installation and Maintenance Case (ref. VLP5) contains essential tools for installing and maintaining the sensors and relay.

Such tools are: laser sight (ref. VLP2) and USB configuration cable. It is important that this case is in the possession of the Zyggot Temperature System user, in order to carry out any maintenance properly.

Laser sight

The laser sight is an essential tool to direct the sensor to the desired target. The sight makes installation easy.

Configuration Cable (USB)

The USB configuration cable (ref. ZCC180) is used to connect the tubular sensor to the PC. Allows the configuration of each sensor by the Zyggot manager software

COD: VZX/V5F/N ou VZX/V5F/S

RELAY 96 X 125 Touch Screen

Technical information

V5F RELAY FEATURES

Power Supply	24 VDC
Moisture	5 to 95%
Sensores N.	up to 125 sensors
Resolution	1°C
Inputs	4 analogue 4 digital (24VDC)
Outputs	2 outputs for Alarme and Trip (N.O.) 2 programmable outputs (N.O.) 1 output for connection of the sensors
Communication	Modbus RTU Devicenet (optional) Ethernet TCP-IP (Included)
Screen	Color, Touch Screen WVGA

RELAY
Relays are available in 4 models

VZX/B1/U: with monochromatic liquid crystal display and keys (see specific manual).

VZX/V5L/N or VZX/V5L/S: with color touch screen, normal (end N) or Fail Safe (end S).

VZX/V5F/N or VZX/V5F/S: Same as VZX/V5L but with expansion modules for 12 digital inputs and 12 outputs (See Specific Manual).

COD: VST/M/7/300/24

TUBULAR SENSOR

Technical information

FEATURES: EBLOCK 88x (x=D or x=R)

Power Supply	24 VDC (10 - 30 VDC) 2W
Moisture	5 to 95%
Communication	CAN
Temperature	Oper: 0 to 60 °C /// Armaz: -10 to +60 °C
Inputs	8 Digital Inputs (12 - 24 VDC)
Outputs	Model 88D = 8 Digital Outputs (DC) Model 88R = 8 Digital Output (Relay)
Inputs	Imp.: 10K /// Treshold: 8 VDC / 3 VDC
Distance Max	1000 M
Output Current (Model 88D)	2,5 A Max per point /// 10A Total Max (model 88D)
Output (mod 88R)	3,0 A @ 250 VAC Res. Max (mod. 88R)

SENSORS
Sensors are available in two models.

VST/M/7/300/24: tubular sensor, for medium and low voltage applications.

VS/M/60/120/24: LV sensor, for low voltage bus applications.

Both with two mini USB connections for connecting cables.

COD: ZSB/M/60/120/24

BT SENSOR

Technical information

FEATURES: TUBULAR SENSOR

Measurement angle:	7°
Typical read error (*):	+/- 0,5°C (trg: 0-125°C)
Normal Distribution (125 s):	0.48°C at 80°C target
Emissivity:	Programmable (0,95 std)
Resolution:	1°C
Target reading:	0 to 300 °C
Environment reading:	0 to 75 °C
Power:	24 Vcc
Diameter:	19 mm
Length:	53 mm
Communication:	Modbus RTU
Material:	Stainless Steel / Polycarbonate

(* See test report at the end of this manual)

COD: ZA232-2

Y SPLIT DERIVATOR RS232

COD: VPS6024 ou VPS 12024

POWER SUPPLY 24 VDC

Included with each sensor

Quick Fix Support for the BT Sensor

Technical information

FEATURES: BT SENSOR

Measurement angle:	120°
Typical read error (*):	+/- 0,5°C (trg: 0-125°C)
Normal Distribution (125 s):	0.48°C at 80°C target
Emissivity:	Programmable (0,95 std)
Resolution:	1°C
Target reading:	0 to 120 °C
Environment reading:	0 to 75 °C
Power:	24 Vcc
Diameter:	54 mm
Length:	31 mm
Communication:	Modbus RTU
Material:	Polycarbonate

(* See test report at the end of this manual)

COD: V5CON (included with each Relay)

INTERFACE

COD: EB/88D ou EB/88R (Para ser utilizado com o relé V5F)

EBLOCK P/ MODELO V5F

Informações Técnicas

Connectors: EB/88D & EB 88R (*)

1:	Digital Outputs / Relay Outputs
2:	NET address selection switches
3:	LEDs de status
4:	Inputs
5:	CAN & Power Supply
6:	Ground
7:	CAN RJ45

ACCESSORIES AND SPARE PARTS

Accessory

COD: VPS6024 or VPS12024



POWER SOURCE

Accessory

COD: ZSF2



Support for fixing and sight for tubular

Accessory

COD: VZX/B1/U ou VZX/B1/U/P



SUITCASE WITH LASER SIGHT

Accessory



Y-split Derivator, USB cables and terminating resistor

Accessory

COD: VLP2



Laser sight attachable to tubular sensor for startup

Accessory

COD: ZA232-2



DERIVADOR RS232

Accessory

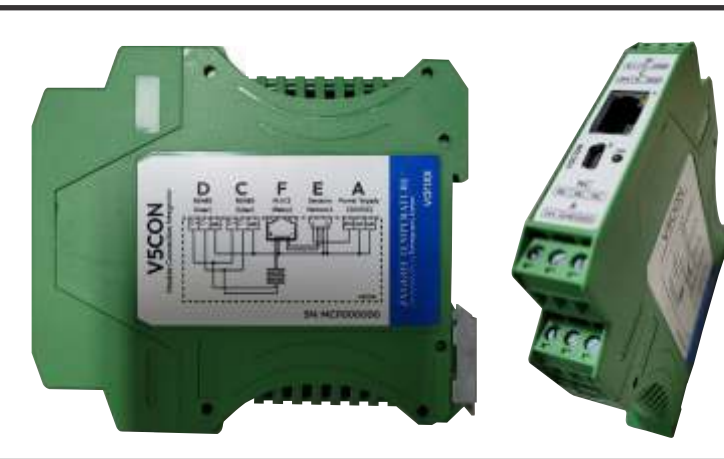

COD: V5CON (included in each Relay)

Interface

Acessório

COD: RJ45/C2 (Included in each module V5CON and each Eblock)



RJ45 CABLE

INTERFACE DETAILS

The V5CON Interface simplifies the connection of the Zyggot V5L relay with the sensor network, Power Supply and also integrates the sensor network termination resistor at the end of the relay and two RS232C to RS485 converters, more suitable for communication over long distances.

It must be installed on a quick fixing rail by the base in the same cubicle where the Zyggot relay is installed.

CONNECTIONS (All at the top)

Port A (Power): Connection to the system's 24 VDC Power Supply. VPS6024 or VPS 12024 sources.

Port F (Relay): Connection with RJ45 cable between the Interface and the Zyggot relay.

Port E (Sensor Network): Connection with mini USB cable and connector between the Interface and the sensor network.

Port C (RS485): RS485 serial connection between the relay and the user's SDCD system.

Port D (RS485): RS485 serial connection between the relay and the user's SDCD system.



Tag

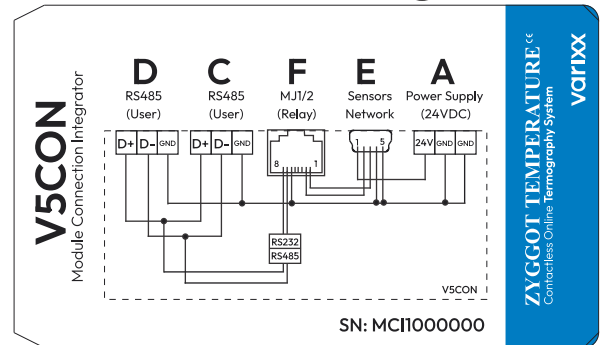

The EBLOCK 88D Module adds 8 digital outputs and 8 programmable digital inputs to the Zyggot V5F relay. The EBLOCK 88R Module adds 8 relay outputs (dry contacts) and 8 programmable digital inputs to the Zyggot V5F relay. These modules (one or the other) are only used in the V5F relay and are not used in the V5L relay.

Digital Outputs		
D. OUT. 1	ALARM	Q1 RELAY
D. OUT. 2	TRIP	Q2 RELAY
D. OUT. 3	D.O. 3	Q3 RELAY
D. OUT. 4	D.O. 4	Q4 RELAY
D. OUT. EB1	AUX 1	Q1 EBLOCK
D. OUT. EB2	AUX 2	Q2 EBLOCK
D. OUT. EB3	AUX 3	Q3 EBLOCK
D. OUT. EB4	AUX 4	Q4 EBLOCK
D. OUT. EB5	AUX 5	Q5 EBLOCK
D. OUT. EB6	AUX 6	Q6 EBLOCK
D. OUT. EB7	AUX 7	Q7 EBLOCK
D. OUT. EB8	AUX 8	Q8 EBLOCK

Digital Inputs		
D. INP. 1	EXT. F. 1	I1 RELAY
D. INP. 2	EXT. F. 2	I2 RELAY
D. INP. 3	MUTE	I3 RELAY
D. INP. 4	RESET	I4 RELAY
D. INP. EB1	AUX 1	I1 EBLOCK
D. INP. EB2	AUX 2	I2 EBLOCK
D. INP. EB3	AUX 3	I3 EBLOCK
D. INP. EB4	AUX 4	I4 EBLOCK
D. INP. EB5	AUX 5	I5 EBLOCK
D. INP. EB6	AUX 6	I6 EBLOCK
D. INP. EB7	AUX 7	I7 EBLOCK
D. INP. EB8	AUX 8	I8 EBLOCK



EBLOCK 88R



Detail of the RJ45 connector for communication with relay (CAN)

MEASUREMENT AREA, EMISSIVITY, MEASURING ANGLES.

Areas depending on distance for the 7 degree sensor

$$\text{Area diameter} = \text{Distance} / 8$$

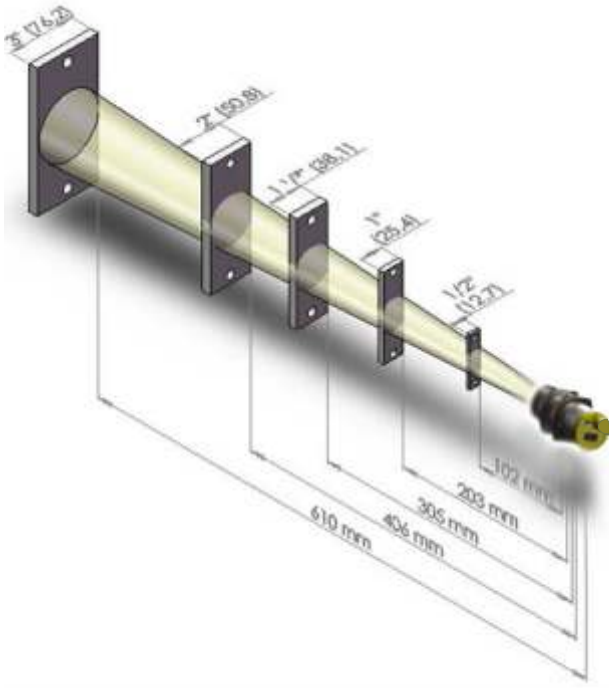

AVAILABLE READING ANGLES.

The Tubular Sensor is supplied with a standard reading angle of 7° (other angles can be provided on request).

The BT Sensor has a measurement angle of 120°

The perfect sight of the object is guaranteed with aim Removable laser.

You can measure objects up to 10 meters away with automatic compensation.

Reading errors, which may occur, and which normally go unnoticed, with measurements using manual guns or even thermographic cameras due to differences in emissivity of the materials.

With the Zyggot sensor pointing to a Unidex tape or even to a thermocontractile coated copper bus (which has an emissivity of 0.95 like the Unidex tape, the temperature reading is accurate, as the sensor is calibrated to 0.95

In short, it is not possible to rely on manual non-contact measurements when dealing with multiple materials without meter calibration for each type of emissivity.

The Zyggot system solves this problem and even provides real-time measurements.

SELECTION OF LENGTH OF CABLES FOR EACH SENSOR.

The tubular sensors are connected by a multiple shielded cable, with mini USB connectors at both ends and each sensor has 2 mini USB connectors making it easy to link one sensor to the next and so on until the relay. Connection cables are supplied in different lengths to facilitate installation. The use of ZTA shunts facilitates installation and can be used freely.

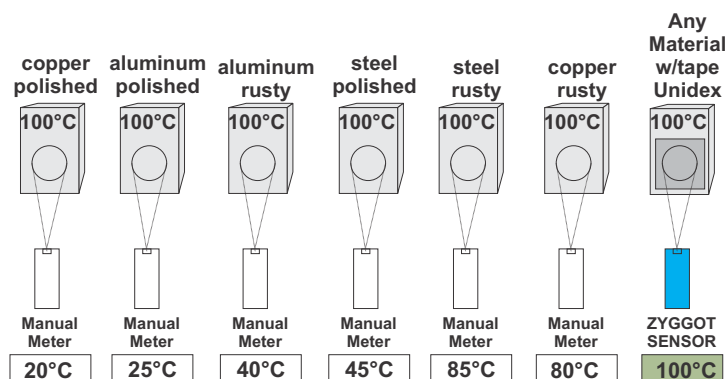

ONEWIRE DIAGRAM AND MAIN FEATURES

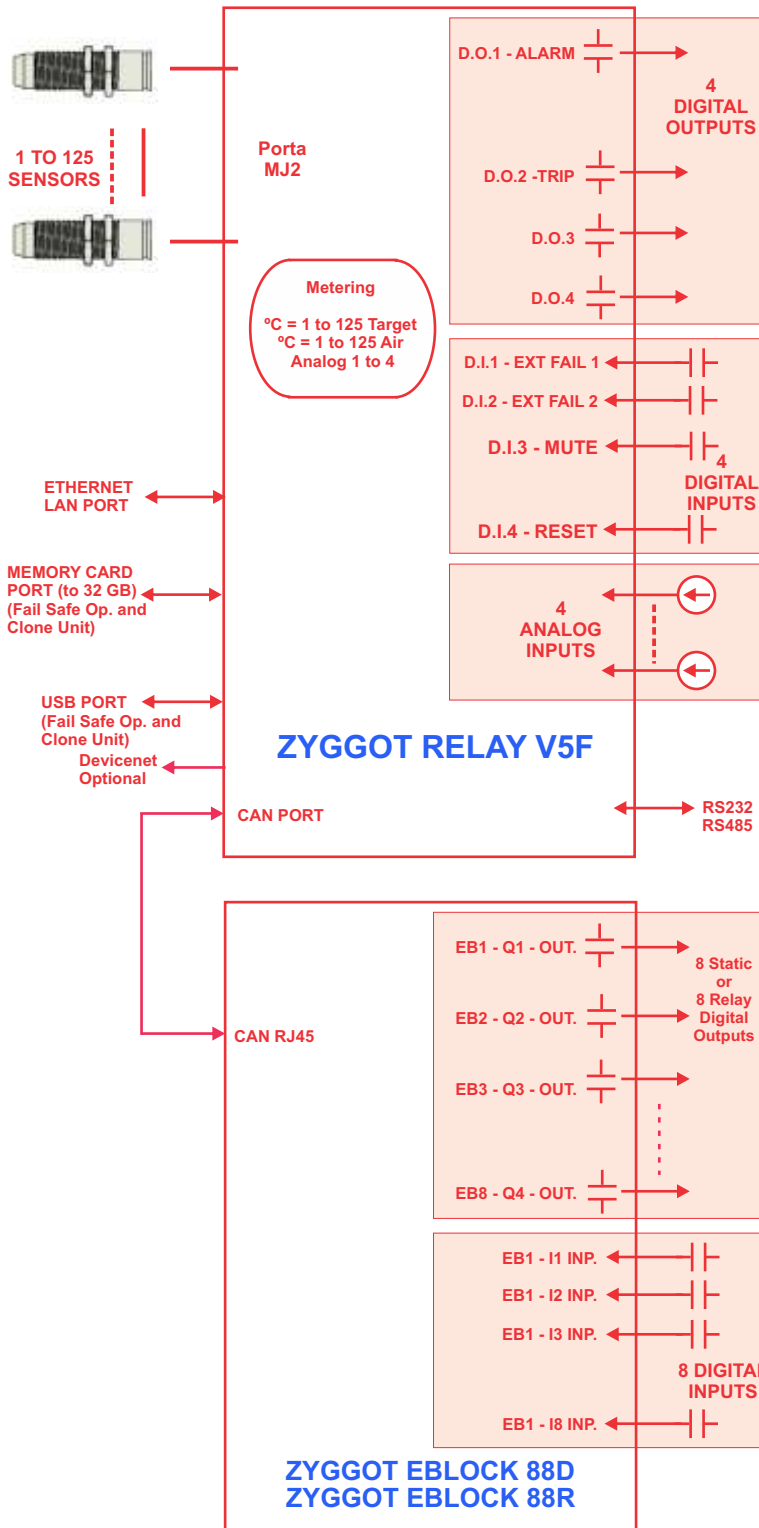

Measurement

- The Zyggot Relay provides accurate measurement of:
- * Up to 125 target or area temperatures.
 - * Up to 125 air temperatures surrounding the sensor.
 - * 4 12-bit analog inputs for measurement and protection of external variables, such as other temperatures acquired by thermocouples etc.
 - * Operating hours.
 - * Integrity of sensors on the network (Not Responding or OK).

Display

Touch Screen graphic display, with trending capability. Trending shows in real time in graphs of up to 3 sensors per screen the real behavior of any temperature or analog input. 64k colors.

Aiming tool

A laser pointer can be screwed onto the front of the sensor body only during installation, allowing quick and safe attachment of the sensors, then being removed. A single pointer is both necessary and sufficient.

Programming tools

A free program developed with graphical windows is provided free of charge by Varixx to further facilitate the parameterization of the relay. Even without this program, it is very easy to parameterize the relay via the HMI, with interactive and user-friendly menus. Another program tests and parameterizes each sensor (emissivity and address).

Event memory

The relays allow the memorization and indication of the last 120 faults with date and time of occurrence. These indications are not lost even if the relay is turned off.

Communication ports

The ZYGGOT V5F relay has 1 RS232 or RS485 programmable communication port with converter, which can be used for communication with supervisory systems or PLCs with Modbus RTU communication protocol. Another CAN port with CsCAN or Devicenet protocol (Optional) allows communication and expansion. There is a USB port and a Memory Card port up to 32 GB. An ETHERNET LAN port is also available.

Analog Inputs

The Zyggot V5F relay has 4 12-bit analog inputs that can be used for measurement and protection, linked to external temperature and other transducers.

Digital Inputs

Zyggot V5F relays have 4 configurable digital inputs, which can for example be connected to panel door micro switches or ventilation airflow sensors.

Digital outputs

4 digital static outputs are available on the relay and 8 digital static outputs (model Eblock 88D) or 8 relay outputs (dry contact) (model Eblock 88R), all configurable for alarm or trip, to indicate any of the faults. Digital outputs are available to indicate any of the faults.

Topology

Tubular sensors allow quick and easy installation and parameterization.

PROTECTIONS AND COMPENSATION OF EMISSIVITY WITH UNIDEX TAPE

FACTORS THAT INFLUENCE THE ACCURACY OF TEMPERATURE READINGS AND ZYGGOT SYSTEM

- * Wave-length → ✓ Sensor calibrated in the optimal range
- * object surface → ✓ Automatic emissivity correction
- * Sight angle → ✓ Up to 60° without error introduction
- * sensor temperature → ✓ Readed and corrected internally

FUNCTION TABLE

PROTECTIONS AND FUNCTIONS

ANSI	DESCRIPTION	TRIP	ALARM	Monitor
94	2 x Assignable External	✓	✓	
49	125 Target Overtemperature	✓	✓	
49	125 Case / Air Overtemp.	✓	✓	
30	Anunciator w/ Time Stamp	✓		
	Several Communication Options			✓
	Event Recorder			✓
	Readings 4 External Analog Signal	✓	✓	
	Readings - 125 Target °C			✓
	Readings - 125 Case / Air °C			✓
	Trendings - Real time curves			✓



Unidex adhesive tape

In the photo you can see a roll of Unidex adhesive tape, with known and constant emissivity, from room temperature to 250°C, which can be cut and glued in the areas of interest, guaranteeing accurate readings.

If the target material has low emissivity, stick the Unidex tape supplied with the sensor to cover the area to be measured. If you do not use Unidex tape, take into account the emissivity index of the target, according to table 1 or by comparison, when programming each emissivity index in the sensor. The use of Unidex tape is recommended for ease of calibration and better accuracy of readings.

The perfect sight of the object is guaranteed with aim Removable laser.

LASER SIGHT

Once the sensors are installed, the pointing direction must be checked, precisely at the target. For this, a laser sight is used, which is supplied as an accessory, in a case that contains the sight and battery power supplies.

The Laser sight must be screwed onto the front of the sensor. Once correctly aimed at the target (if using a special bracket supplied as an accessory, this adjustment is very easy). Once the correct sight has been checked, the screw support is removed. If the sensor is relatively close to the target this process can be dispensed with, if the support has been designed correctly to already have a correct position.

Briefcase with Laser Sight (used for the Tubular sensor)



TYPICAL CONNECTIONS

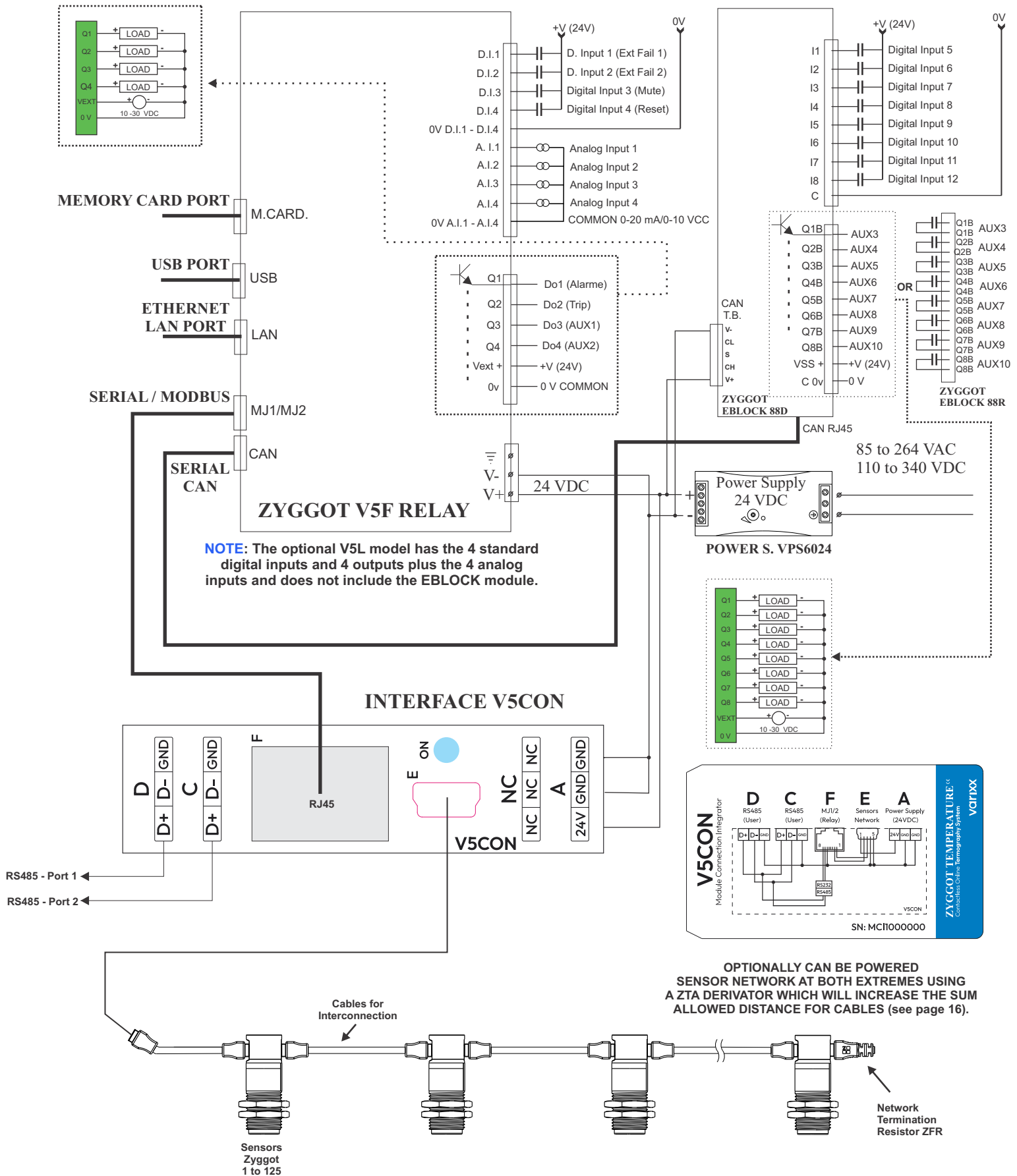

CONNECTIONS

External Fault Connection Usage Example

ZYGGOT THERMOGRAPHY



ZYGGOT VOLTAIC ARC



One or two Zyggot Arc Flash relays by Ultra-violet detection connected to External Fault 1 and/or 2 input for Real Time History purposes. Each Zyggot Arco Relay can monitor up to 50 sensors and as one sensor is normally used per cubicle, up to 50 cubicles can be protected per Zyggot Arc relay.

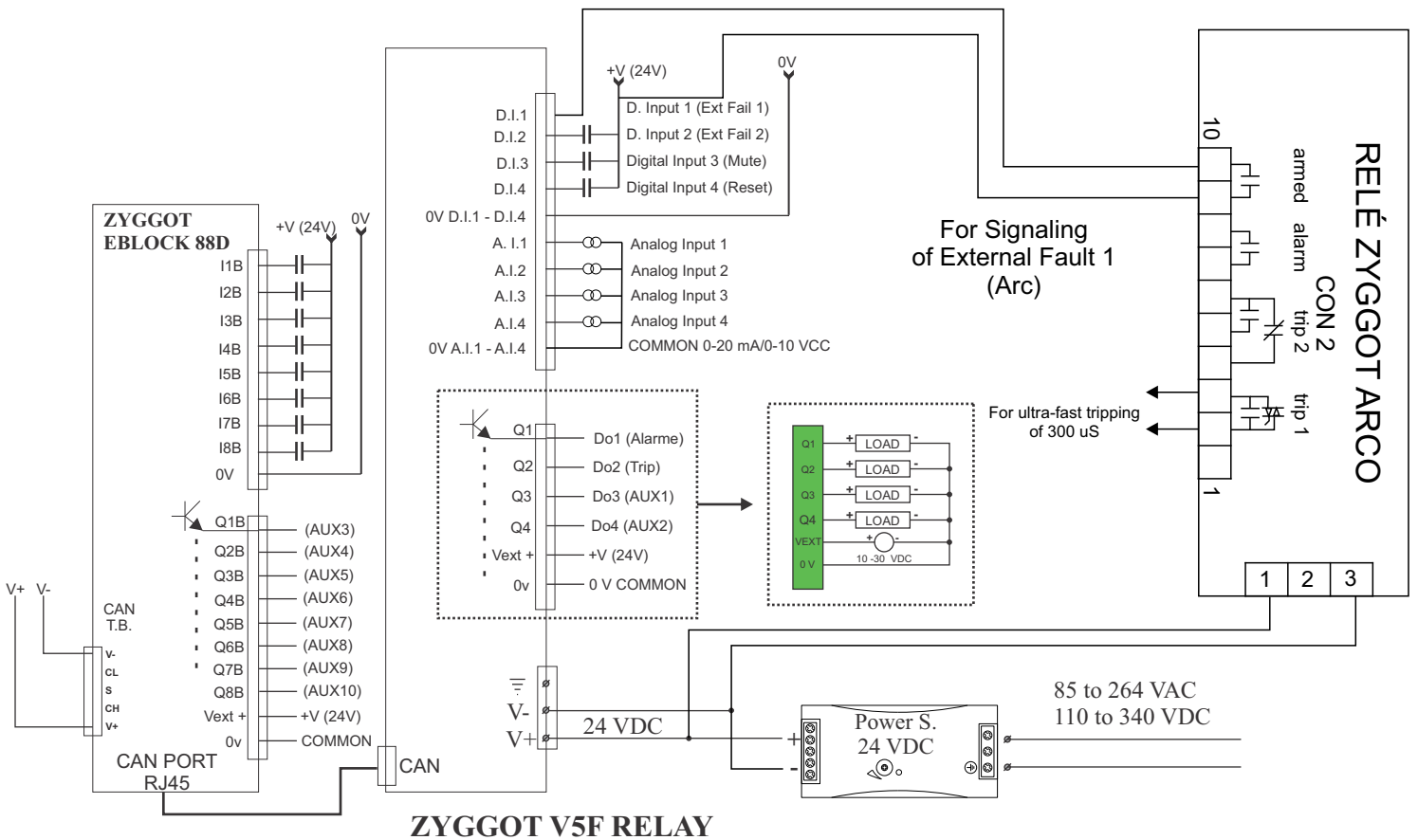

TYPICAL INTERCONNECTIONS

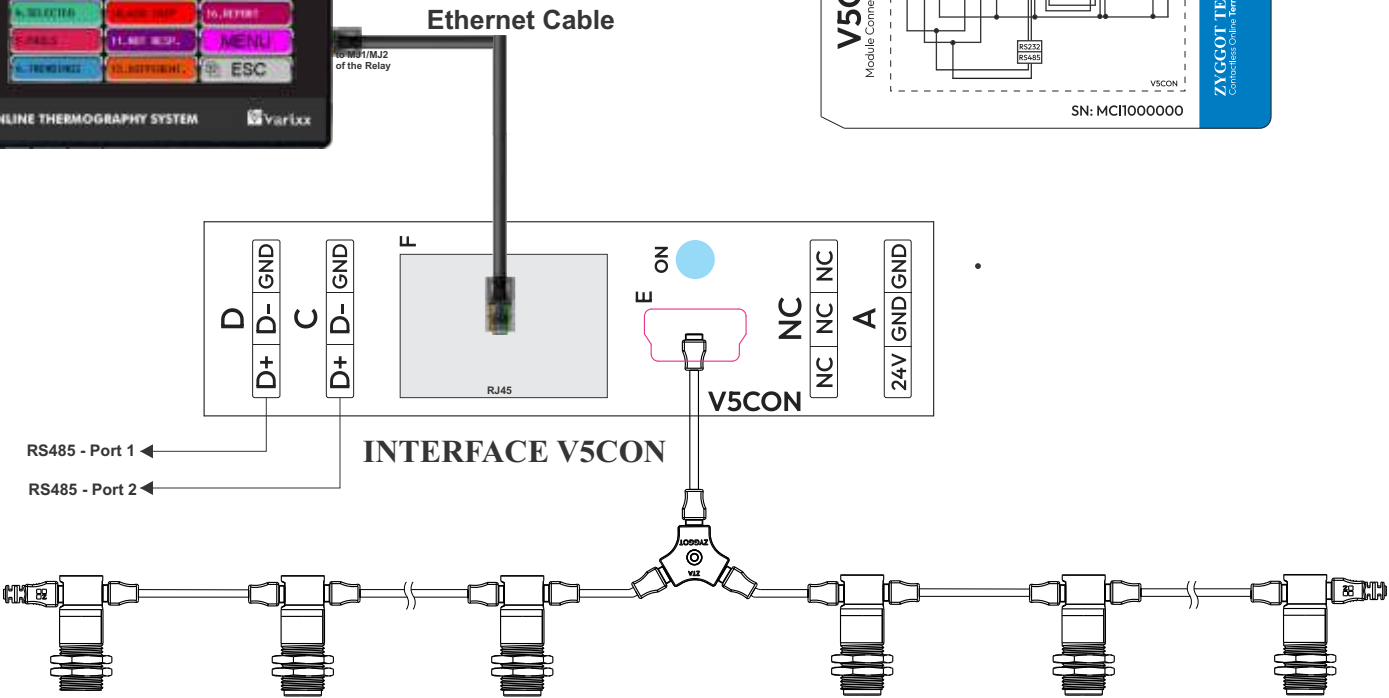
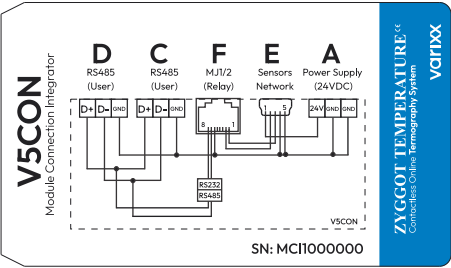

Note: The sum of the distances of the cables must not exceed 80 meters to Maximum 125 sensors or connect by both ends to double the distance (see example below).

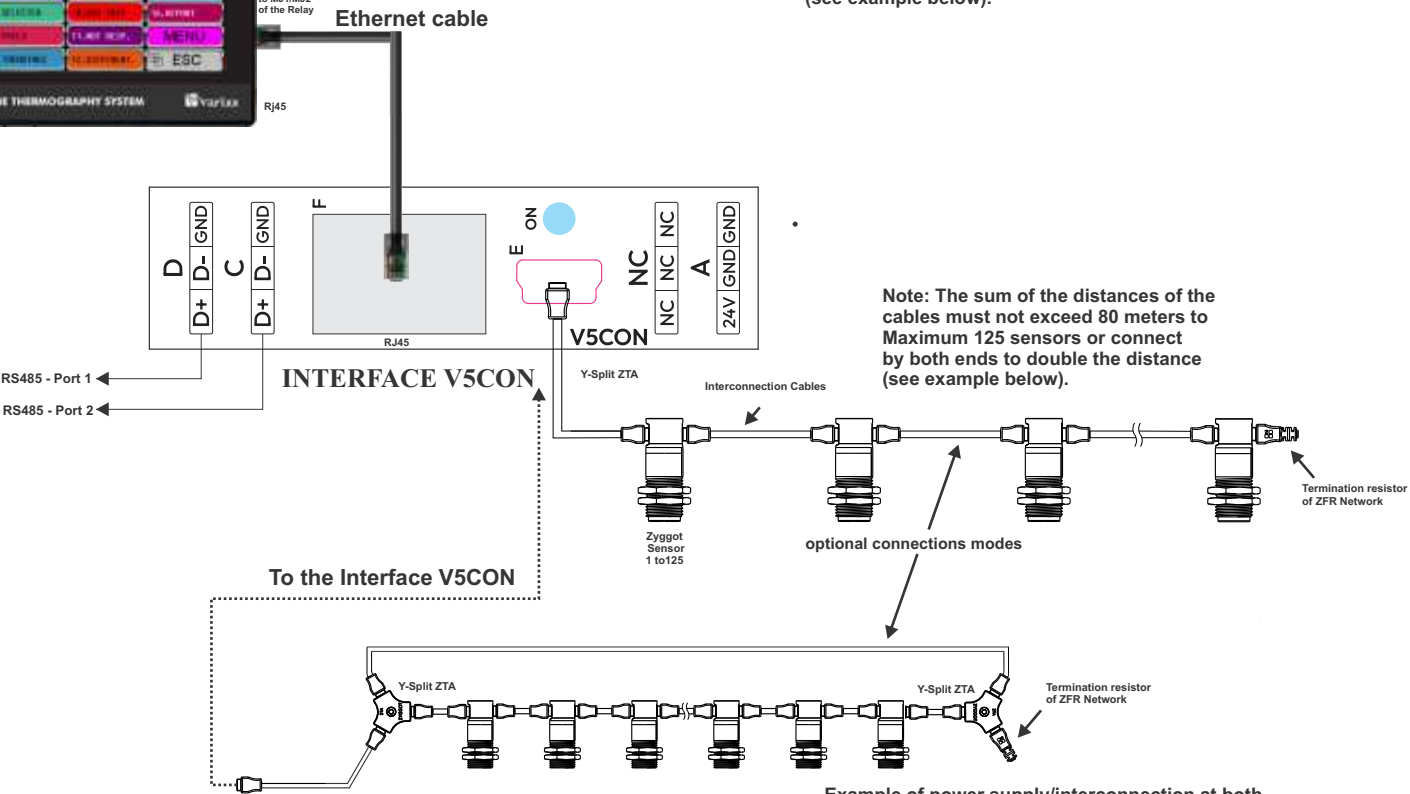

Note: The sum of the distances of the cables must not exceed 80 meters to Maximum 125 sensors or connect by both ends to double the distance (see example below).

Example of power supply/interconnection at both ends in order to increase the distance of the cables to twice what can normally be achieved.

TYPICAL INTERCONNECTIONS



To MJ1/MJ2 of the Relay
Ethernet Cable
RJ45

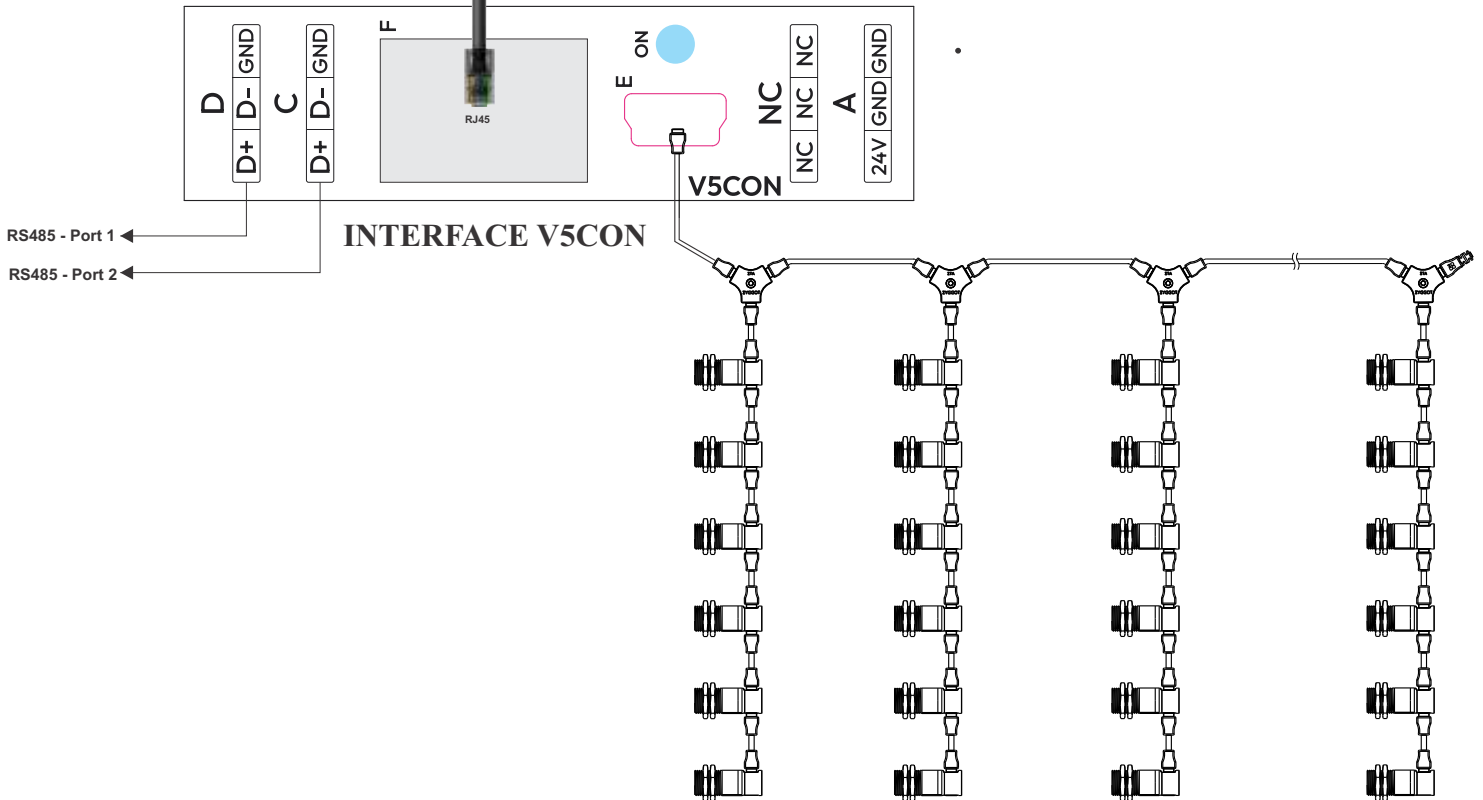
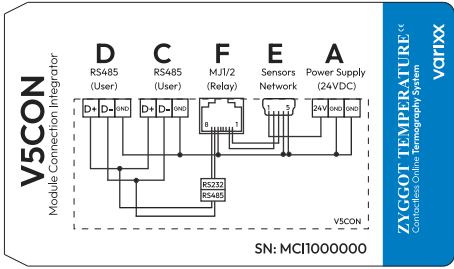

Note: The sum of the cable distances must not exceed 80 meters for a maximum of 125 sensors or supply/interconnect them at both ends using ZTA split to increase the distance (see example at page 16).

MECHANICS



- 1- POWER 24 VCC
- 2- D.I. / A.I. CONNECTOR
- 3- D.O. / AQO. CONNECTOR
- 4- CAN PORT
- 5- RS232/RS485 SERIAL PORTS
- 6- CONFIGURATION SWITCHES
- 7- ETHERNET LAN PORT
- 8- MICRO SD SLOT
- 9- USB PORT



PANEL CUT OUT

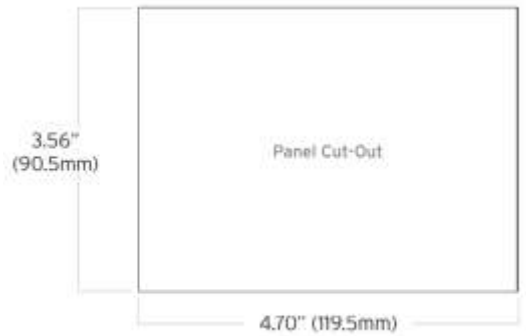

EBLOCK 88R

- 1- DIGITAL DC OUTPUTS
- 2- NETWORK ID SELECTOR SWITCHES
- 3- STATUS LEDs
- 4- DIGITAL DC INPUTS
- 5- CAN and POWER
- 6- EARTH GROUND
- 7- CAN PORT - RJ45

EBLOCK 88D or EBLOCK 88R

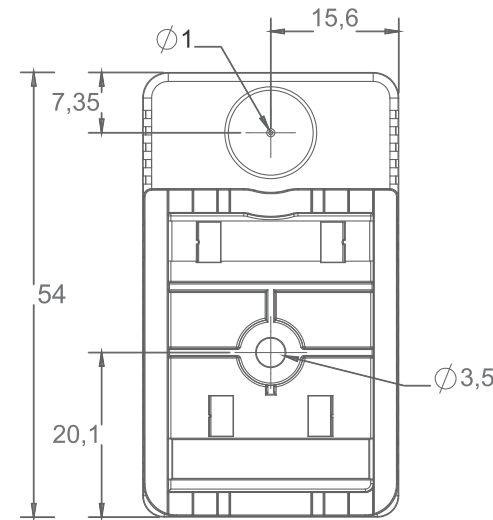
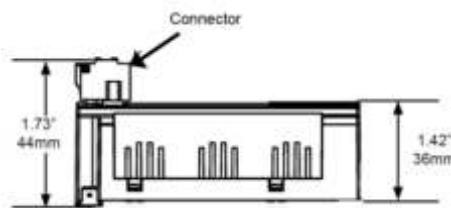
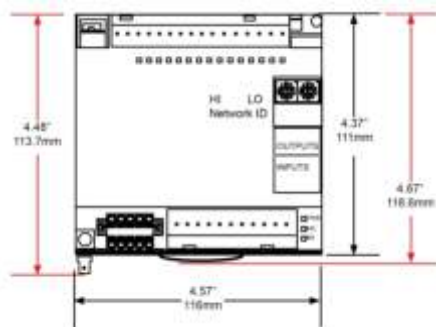

BT SENSOR

DIP SWITCHES			
PIN	NAME	FUNCTION	DEFAULT
1	RS-485 Termination	ON = Terminated	OFF
2	CAN Termination	ON = Terminated	OFF
3	Bootload	Always Off	OFF

DIP Switches at Relay

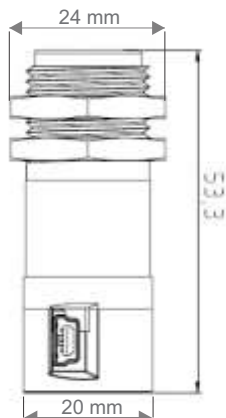

TUBULAR SENSOR

Address Rotary Switches for CAN at Eblock 88x fro 1 to 253 (decimal) or 01 to FD (Hexadecimal)



TECHNICAL CHARACTERISTICS

CHARACTERISTICS RELAY V5F + EBLOCK 88x

Power Supply	24 Vcc, 150 mA
Moisture	5 to 95%
Dimensions Relay	96 mm x 125 mm x 31 mm
Dimensions Eblock	
Connections Relay	1 x RS232 1 x RS485 1 x CAN (125 Kbps - 1 Mbps) 1 x Ethernet (1-10 Mbps/100 Mbps) 1 x USB Mini Program 1 x USB Flash 1 x Micro SD/SDHC
Inputs Relay + Eblock	4 analogue 0-20 mA (50 ohms) 12 Bits, Error: 1.5% FS Max 4 + 8 digital 0-24 VDC Min On= 8VDC. Max Off: 3VDC
Outputs Relay + Eblock	4 + 8 (10 Programmable), Half-Bridge 0.5A max, 10 to 30 VDC, C. Source + Protection: Short and Overvoltage. or 8 Relay 3A @ 250 VAC Resist. Load
Communication Relay	Modbus RTU, CsCAN Ethernet, Devicenet (Optional)
Communication Eblock	CAN
Relay Screen	Color Screen, WVGA (480 x 272) Colors = 64K Resistive Touch Screen 4,3" 450 cd/m ²
Certificates	CE / FCC Compliance - Part 15 of FCC
Connectors	3,5 mm - Pluggable
Weight	Relay: 270 g /// Eblock: 340 g
Temperature	Operation: -10°C to 60°C Stored: -30 °C to 70 °C
Battery RTC Relay	Operation: > 10 Years Stored: 5 to 10 years Clock Error: 8 s / month at 25 °C max

CONFIGURATION AND TESTING OF SENSORS

A sensor configuration program, free of charge, once installed on a PC, allows correctly configuring each sensor, before installing them in the panels or even after they are installed. The sensor can be reconfigured many times as necessary. More details in the chapter «Sensor Configuration» later in this manual.

RELAY VZX V5F:

- Ambient Operating Temperature: 0 to 45°C.
- Storage ambient temperature: -40 to 85°C.
- Relative Humidity: 5 to 95% N.C.
- NEMA Rating: NEMA 4X.
- Relay weight: 270 Grams.
- Dimensions: 125 x 96 x 31 mm.
- Noise immunity (EMC Immunity): EN61000-4-2 / EN61000-4-4 / EN61000-4-5 / EN61000-4-12 / ENV50140/50141
- Emissions: EN50081-2 / EN55022 / CISPR11. Class A.

CAN NETWORK:

- 1: V+
- 2: CAN H
- 3: SHIELD
- 4: CAN L
- 5: V -

CAN POWER RANGE:

12 to 25 VCC / 75 mA MAXIMUM.

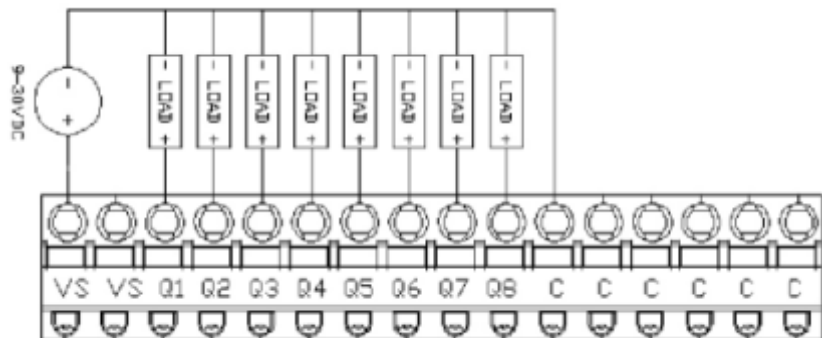

EBLOCK EB/88D OUTPUTS

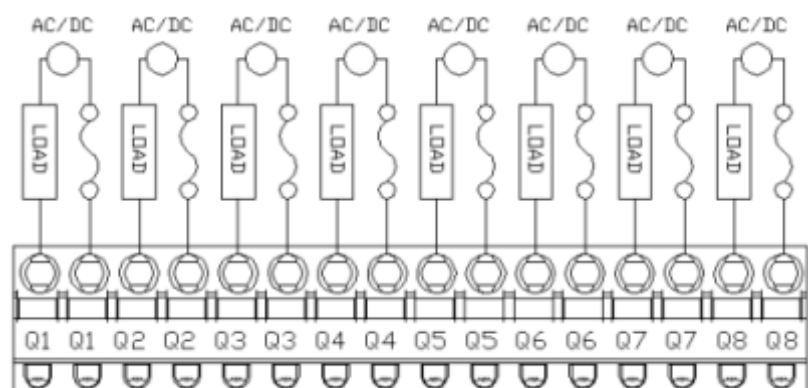

EBLOCK EB/88R OUTPUTS

ONLINE THERMOGRAPHY WITHOUT CONTACT OF ACTIVE PARTS WITH THE BUS. THE TUBULAR SENSOR TYPE IS POSITIONED AT A DISTANCE, BEING INDICATED FOR MEDIUM AND HIGH VOLTAGE AND THE BT SENSOR IS FIXED ON THE BUS, BUT ONLY THE POLYCARBONATE PLASTIC BOX, RESISTANT TO 200 °C, STAY IN CONTACT. THE MEASUREMENT SENSOR IS NOT IN CONTACT, MEASURING ALSO BY IRRADIATED INFRARED. THE SENSORS ARE POWERED BY THE NETWORK CABLE.

TECHNICAL SPECIFICATIONS

POWER SUPPLY

Signal Pin	Description
V+	Input power supply voltage
V-	Input power supply ground
Gnd	Frame Ground

GENERAL CHARACTERISTICS

- ! Graphical LCD Touch Screen w/ Backlight.
- ! 24 VDC
- ! RS-232 / RS-485 Serial Ports.
- ! Integrated Bezel.
- ! Real-Time Clock.
- ! Flash Memory for easy field upgrades.
- ! Ethernet LAN Port.
- ! USB port e Memory Card (to 32GB) available.

CAN or CsCAN (OPT)

Peer-to-peer network. CAN-based network hardware is used in the controllers because of CAN's automatic error detection, ease of configuration, low-cost of design and implementation and ability to operate in harsh environments. Networking abilities are built-in to the control Module and require no external or additional modules.

CAN Network Baudrate vs. Total Cable Length

Network Data Rate Maximum	Total Cable Length
1Mbit / sec.	40m (131 feet)
500Kbit / sec.	100m (328 feet)
250Kbit / sec.	200m (656 feet)
125Kbit / sec.	500m (1,640 feet)

Mj1/ MJ2 PORT MODULAR JACK

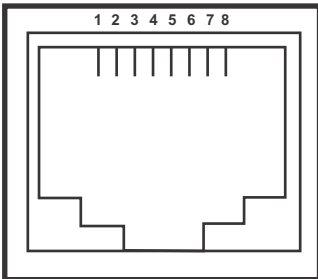

MJ1 PORT

PIN	SIGNAL
1	-
2	-
3	CTS
4	RTS
5	+5 V
6	0 V
7	RXD
8	TXD

Output Power Supply Max 150 mA

Characteristics

Display Type (LCD Touch Screen):	64K Color Touch Screen
Display Size:	4,3"
Display Screen:	480 x 272 pixels
Touch Screen Type:	Resistive
Number of Colors:	64K
Power Current:	150mA @ 24VDC
Inrush Current:	(20A @ 24VDC) for 1ms.
Height:	96.0 mm)
Width:	125 mm)
Mounting Depth:	31 mm)
Weight	270 g)
Keypad Material:	Lexan HP92 by GE Plastics.
Protocols supported Serial Ports:	CsCAN, Modbus Master, Modbus Slave, and ASCII
Read and Write	
CAN Ports:	CsCAN (up to 253 drops)
Serial Ports:	2: RS-232 / RS-485 Ports.
Network Ports:	1: CAN (CsCAN peer)
Temperature & Humidity:	10 - 60°C,
5 to 95% Non-condensing	
CE	Compliant

CAN PORT PINS

PIN	SIGNAL	DESCRIPTION
1	V-	POWER -
2	CN_L	SIGNAL -
3	NC	NC
4	CN_H	SIGNAL +
5	V+	POWER +

Note: To optimize CAN network reliability in electrically noisy environments, the CAN power supply needs to be isolated (dedicated) from the primary power. The CAN Shield must be attached to the panel as close to the Relay as possible.

MJ2 PORT

PIN	SIGNAL
1	RX+/TX+
2	RX-/TX-
3	-
4	-
5	+5 V
6	0 V
7	-
8	-

Output Power Supply Max 150 mA

MAIN SCREENS FOR OPERATION

a- MAIN MENU, (ESC) INFO SCREENS



MAIN MENU:

Screen from which all other system screens are accessed. From there, all operating and programming screens are accessed.

Note that, to eventually call the operator's attention, the «ALARM» field will flash and have a red border to inform that there is an not visualized (not Acknowledged) or Cleared (Cleared) alarm on the alarm screen. By tapping this field, the alarm screen is entered and the alarm can be acknowledged and reset. More details ahead.

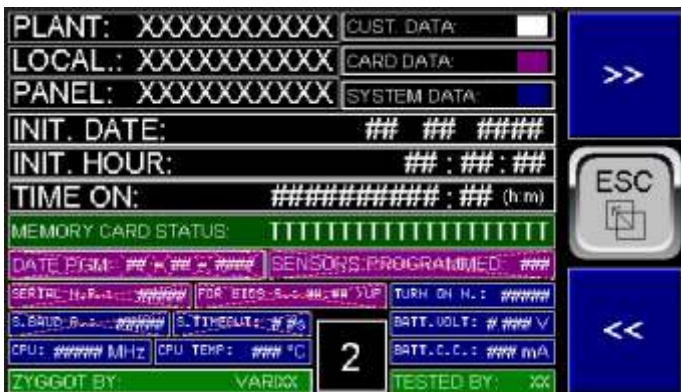

INFO SCREENS 1 to 5:

There are 3 screens paged by the >> and << keys and accessed through the ESC key on the main menu.

INFO SCREEN 1: There is a lot of information. When powering up the system this is the splash screen. Pressing ESC takes you to the main menu above.

VERS: Software version

S.COMM OK: Indicates that the sensor network is communicating OK.

S.COMM ERROR: Indicates that the sensor network is in error communication.

DATE, TIME and DAY OF THE WEEK: from the internal real-time clock.

FAIL: Indicates failure not reseted.

TRGT: Indicates target-related failure.

ATTENTION: THE RELAY ZYGGOT V5L LEAVES THE FACTORY WITH A PASSWORD TO ENTER THE PROGRAMMING MENU = «1» CHANGE IT WITHIN THE «RELAY CONFIG» MENU TO ANY OTHER VALUE (RECOMMENDED).

MAIN SCREENS FOR OPERATION

b- MAIN MENU, (ESC) INFO SCREENS

AIR: Indicates air-related fault (sensor bodies).

NR: Indicates the existence of 1 or more sensors not responding in the network.

ALRM: Indicates unsilenced (not muted) alarm condition and active alarm output.

TRIP: Indicates Trip fault condition (Trip output active)

INFO SCREEN 2: Shows information of plant names, Site and Panel, date and time of start of operation, total system operation time, relay serial number, software serial number, number of times the relay has been turned on, Baud Rate and Timeout of the sensors communication network, number of programmed sensors and finally it also shows some hardware information.

Other fields as in screen 1.

INFO SCREEN 3: Mute Alarm and Reset Fail buttons.

When in the active alarm condition, the Mute button silences it (turns off the Alarm Output).

Being in the mute condition (already muted) the Reset button clears the fault and turns off the Trip Output.

Other fields as in screen 1.

Fail Active: Indicates that there is an active failure.

Alarm Unacknowledged: Indicates that there is an alarm not yet acknowledged by the operator on the alarm screen and depending on what is programmed in the Reset on Fail Unacknowledged parameter, it will not be possible to reset the faults and cancel the trip output.

Alarm Uncleared: Indicates that there is still an alarm not cleared (cleared) by the operator on the alarm screen and depending on what is programmed in the Reset on fail Active parameter, it will not be possible to reset the faults and cancel the trip output.

INFO SCREEN 4: «Fail Safe» system information such as **Auto-load Enabled**, **Auto-run Enabled**, **Flash Backup Done** (these 3 fields must be active, in green color for the «Fail Safe» system to operate correctly if necessary).

Flash Backup Cleared: It will indicate in yellow if there is no Backup file in the Flash memory. To create the backup file, enter the programming menu and create it after having all the parameters programmed and with the relay operating correctly.

Auto Restore Done, Indicates if there was an automatic software restore.

Autoload Fail, indicates if the restoration failed.

INFO SCREEN 5:

On this screen, you can command the write and read protection on the memory card for safe removal and insertion of the card, with the relay in operation, preventing it from being manipulated during writing operations that could corrupt it.

Remove/Insert: This button is invisible if the relay is in writing or reading operation so that the Remove/Insert command is not inserted at an inappropriate time.

Wait: If active, it indicates that the relay is in writing or reading operation.

No Card: Active if the relay has no memory card inserted.

Card OK: Indicates the card is inserted and operating properly.

Ready to Remove/Insert: After the Remove/Insert command chosen in the «Yes» option, this indication is active, indicating that the card can now be removed or inserted.

Memory Card Status: May show one of the following phrases depending on the current system condition:

- 1- Card OK - Operational
- 2- Unknown Format
- 3- No card in slot
- 4- Card Not Supported
- 5- Illegal Swapped
- 6- Unknown Error
- 7- Access Protected

After the Insert/Remove command chosen in «Yes» the sentence will be «6- Access Protected».

Attention: Removing the card without the Insert/Remove command, inserts the Alarm condition in the Alarm and History screen if the action for this fault is selected for «Log» in the programming menu. If the action is selected for «None» this alarm will not be logged.

If the card is removed after the Insert/Remove command, the alarm will not be triggered even if programmed to «Log»

MAIN SCREENS FOR OPERATION

1a- MAIN SCREEN

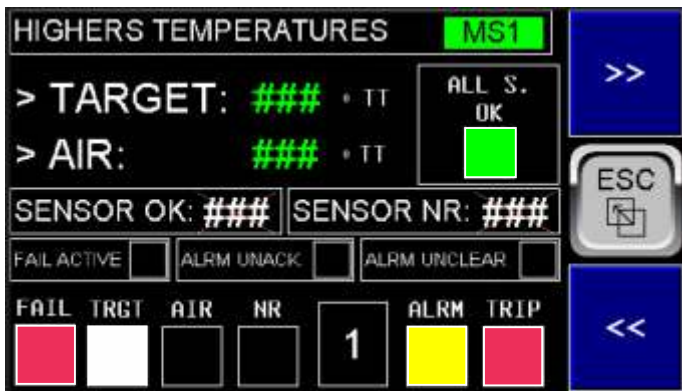

MAIN SCREEN MS1 to Ms12:

MS1:

> **TARGET:** Shows the highest measured target temperature among all sensors.

> **AIR:** Shows the highest Air/Sensor Body temperature measured among all sensors.

SENSOR OK: Shows the number of sensors responding and in OK state in the network (Must be equal to the number of sensors in the network).

SENSOR NR: Shows the number of sensors not responding in the network (Must be zero always).

FAIL: Indicates Active Failure.

TRGT: Indicates Over-Temperature on any target.

AIR: Indicates Over-Temperature in any of the sensor bodies (surrounding air)

NR: Indicates failure by any number of sensors not responding.

ALRM: Indicates active ALARM output (no mute).

TRIP: Indicates active TRIP output, without Reset.

Fail Active: Indicates that there is an active failure.

Alarm Unacknowledged and Alarm Uncleared: They indicate that there is an acknowledged alarm (Ack) and not cleared (cleared) respectively, still by the operator on the alarm screen and depending on what is programmed in the Reset on Fail Unacknowledged or Reset on fail Active parameters will be able to reset the faults and cancel the trip output.

All S. OK: Active in green if all sensors are OK and responding correctly.

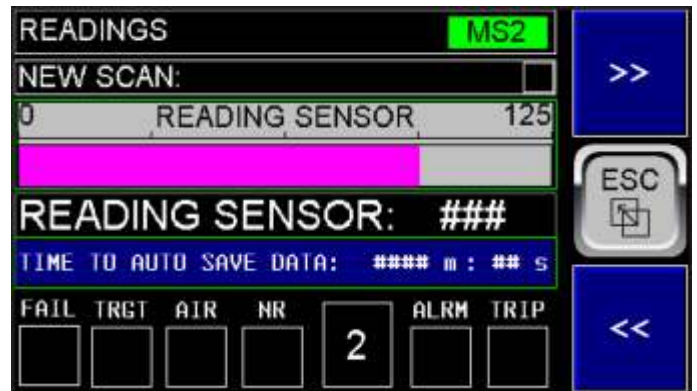

MS2:

NEW SCAN: Indicates a new reading scan of the sensors on the network. This is done continuously.

READING SENSOR: Shows the sensor number being read and a bar graph corresponding to the sensor number currently being read. It serves to show activity and build confidence that the sensors are being read continuously. It also shows the time remaining to re-save target and air temperature data from all sensors if programmed to perform this action. If not programmed, it will always show zero.

The other fields as in MS1.



MS3:

PROGRAMMED: Shows the total number of sensors in the network.

RESPONDING: Shows the number of responding sensors in the network.

NOT RESPONDING: Shows the number of unresponsive sensors on the network.

TOTAL ALARMS: Shows the total number of alarms that have occurred since the last resetting of this number from the programming menu.

TOTAL TRIPS: Ditto for the number of trips that have taken place.

The other fields as in MS1.

MAIN SCREENS FOR OPERATION

1b- MAIN SCREEN



MS4:
DIGITAL INP.1 to 4 and Digital Input EB1 (Aux 1) to EB8 (Aux 8): Indicates status of the digital inputs.
DIGITAL OUT 1 to 4 and Digital Output EB1 (Aux 1) to EB8 (Aux 8): Indicates states of the digital outputs
 The other fields as in MS1.

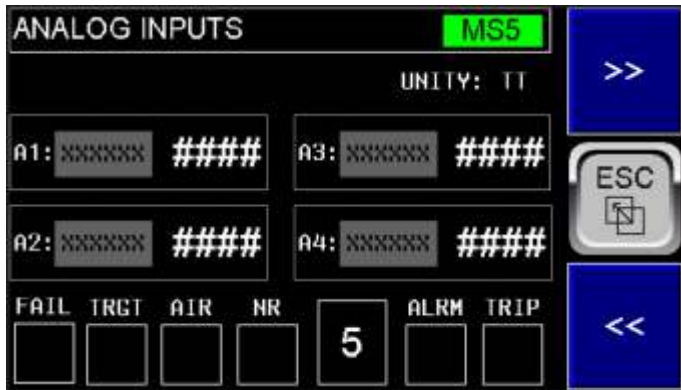

MS5:
ANALOG INP.1 a 4: Shows Analog input values 1 to 4 if used.
 It also shows the name assigned to each entry for easy identification.

The other fields as in MS1.

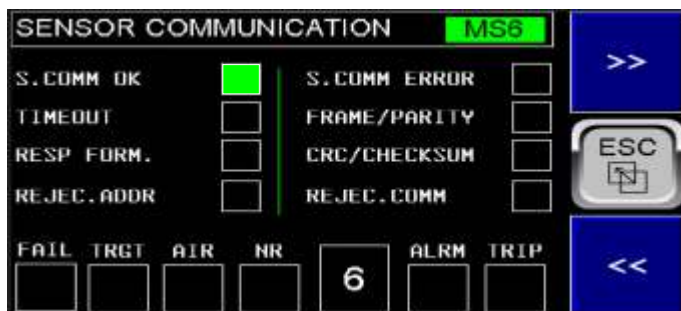

MS6: Relative to communication with sensors.
S. COMM OK: Indicates if communication is OK, no error.
S. COMM ERROR: Indicates if there is a communication error with the sensor network.
TIMEOUT: Indicates if there is a timeout error with the sensors.
FRAME/PARITY: Indicates whether there is a Frame or Parity error on the network.
RESP FORM: Indicates and there is an error for an unexpected response.

CRC/CHECKSUM: Indicates if there is an error by CRC (Cyclic Redundance Check or by Checksum).
REJECT ADDR: Indicates whether the address was rejected.

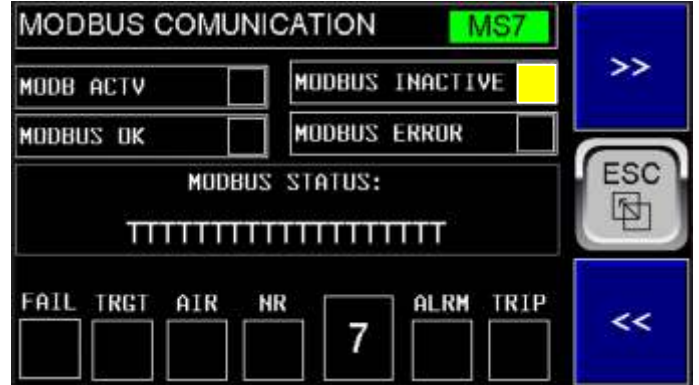

MS7: Relative to Modbus communication
MODB ACTIV: Indicates if MODBUS is active.
MODBUS INACTIVE: Indicates if MODBUS is inactive.
MODBUS OK: Indicates if Modbus is OK, no error.
MODBUS ERROR: Indicates if there is a Modbus error.
MODBUS STATUS: (STANDBY, TIMEOUT, VALID MESSAGE, PARITY ERROR, FRAME ERROR, OVERRUN ERROR, CHECKSUM ERROR, INACTIVE)
 Indicates one of the possible states

The other fields as in Ms1.

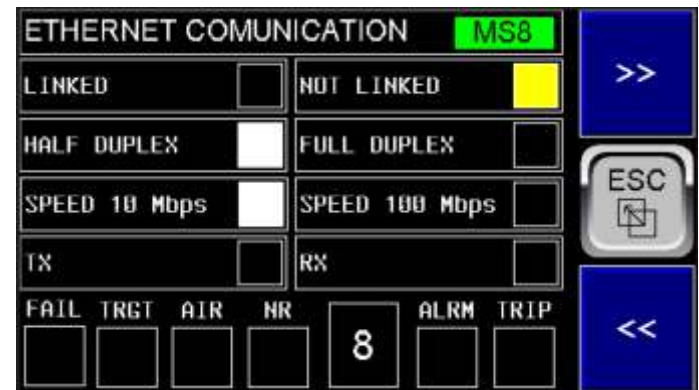

MS8: Relative to Ethernet communication
LINKED: Indicates that the Ethernet cable is connected.
NOT LINKED: Indicates Ethernet cable disconnected.
HALF DUPLEX and FULL DUPLEX: Indicates the current communication mode.
SPEED 10 Mbps e SPEED 100 Mbps: Indicates the current communication speed.
RX: Indicates receiving data.
TX: Indicates transmitting data.

The other fields as in Ms1.

MAIN SCREENS FOR OPERATION

1c- MAIN SCREEN



MS9:
TARGET ALARM: Indicates if there is any target in alarm condition.
TARGET TRIP: Indicates if there is any target in Trip condition.
AIR ALARM: Indicates whether there is any air (body) in alarm condition.
AIR TRIP: Indicates if there is any air (body) in Trip condition.
DIFF ALARM: Indicates if there is any target in differential alarm condition.
DIFF TRIP: Indicates if there is any target in Differential Trip condition.
S. COMM FAIL: Indicates if there is a communication error on the network.
NOT RESP: Indicates failure of Not Responding.
The other fields as in MS1.

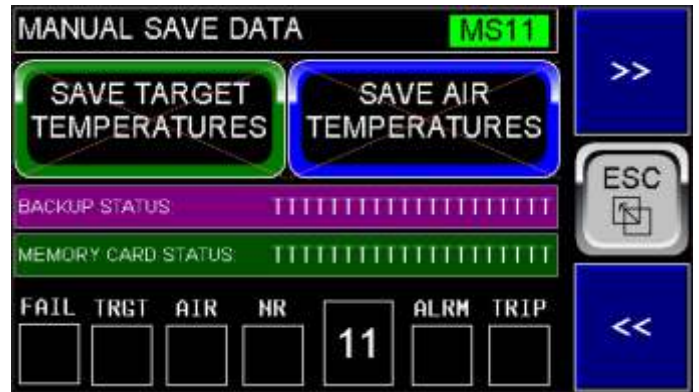

MS11:
 On this screen, the target and air temperature data of all sensors can be saved on the memory card, by manual command, at any time. These files are in Excel CSV format with comma-separated data and can be opened in Excel and generate tables or graphs.
SAVE TARGET TEMPERATURES: When pressed, it has a green background while the ave temperature data is added to the corresponding file on the memory card. This file is located in the **DATAMAN** directory and in the **TRGTDATA** file and the data is added to the existing ones with the following sequence: **dd, mm, yyyy, hh, mm, ss, 0, NS, SR, 0, T1, T2, T3,**Tn. (zero enters as separator).
SAVE AIR TEMPERATURES: When pressed, it has a green background while the air temperature data is added to the corresponding file on the memory card. This file is located in the **DATAMAN** directory and in the **AIRDATA** file and the data is added to the existing ones with the following sequence: **dd, mm, yyyy, hh, mm, ss, NS, SR, 0, T1, T2, T3,.....**Tn. (zero enters as separator).
 The buttons above are invisible if the moment is not suitable for saving the data, for example another instance of recording or reading the card is in progress.
MEMORY CARD STATUS: Shows one of the phrases as described in Info Screen 4 above.
BACKUP STATUS: Displays one of the following phrases depending on the current situation:
 1- STANDBY / 2- OK - PROCEED / 3- ERROR - CHECK CARD / 4- DONT BACKUP ON FAIL / 5- OK - DONE / 6- WRITING / 7- READING / 8- BUSY.

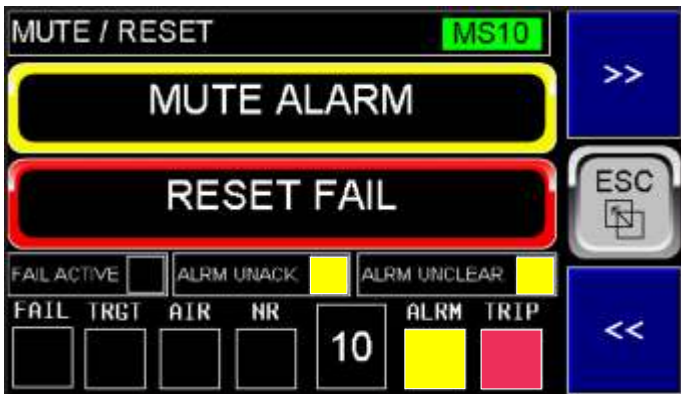

MS10:
MUTE ALARM / RESET FAIL: Buttons that allow you to silence (Mute Alarm) the alarm or reset (Reset Fail) the fault condition. Reset Fail will only act if it is already muted and if programmed 'Reset on Fail' if there is any fault that still exists.
The other fields as in Ms1.

Example below, target temperatures, with 10 sensors, 10 responding. The same applies to the AIRDATA file.



MAIN SCREENS FOR OPERATION

2-TARGET, 3- AIR, 4- SELECTED

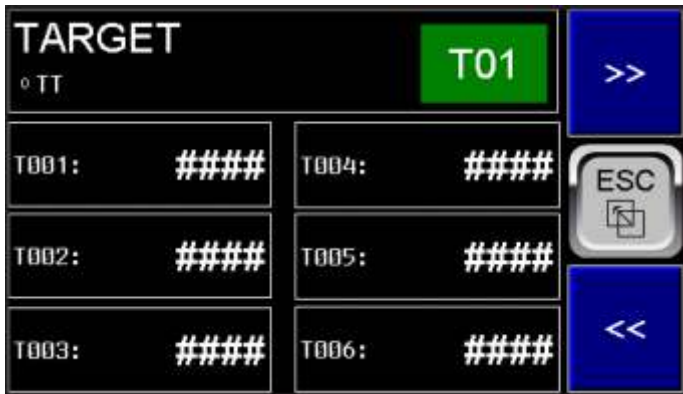

TARGET T01 to T21:

There are 21 screens paged by the >> and << keys.

T01 to T21: Screen Index. Flashes if any of the Target values are above the stipulated alarm value.

°TT: Indicates °C (degrees Centigrade) or °F (degrees Fahrenheit), as programmed.

T001 to T125 (from screens 1 to 21): Shows the current temperature of each target. The color will be White if within the normal range, Yellow if above the programmed Alarm point and Red if above the programmed Trip point. If yellow or red it will also flash.

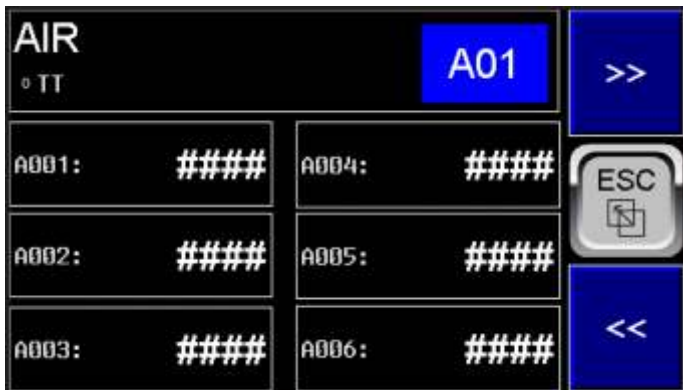

AIR T01 to T21:

There are 21 screens paged by keys >> and <<

A01 to A21: Screen Index. Flashes if any of the Air (Sensor Body) values are above the set alarm value.

°TT: Indicates °C (degrees Centigrade) or °F (degrees Fahrenheit), as programmed.

A001 to A125 (from screens 1 to 21): Shows the current temperature of each target. The color will be White if within the normal range, Yellow if above the programmed Alarm point and Red if above the programmed Trip point. If yellow or red it will also flash.



SELECT TARGET ST01 TO ST4: SELECT AIR SA1 TO SA4:

There are 8 screens paged by keys >> and <<

ST01 to ST4: Screen Index. Flashes if any of the Target values, even if not selected, is above the stipulated alarm value.

T###: Sensor index, from 1 to 125 which the operator can enter by touching this key to monitor the Target Temperature. Flashes if this temperature is above the alarm level programmed for it.

####: Shows the current temperature of the selected target. The color will be **White** if within the normal range, **Yellow** if above the programmed Alarm point and **Red** if above the programmed Trip point. If yellow or red it will also flash.

SA01 to SA4: Screen Index. Flashes if any of the Air (Body) values, even if not selected, are above the stipulated alarm value.

A###: Sensor index, from 1 to 125 which the operator can enter by touching this key to monitor the Air (Body) Temperature. Flashes if this temperature is above the alarm level programmed for it.

####: Shows the current temperature of the selected air. The color will be White if within the normal range, Yellow if above the programmed Alarm point and Red if above the programmed Trip point. If yellow or red it will also flash.

°TT: Indicates °C (degrees Centigrade) or °F (degrees Fahrenheit), as programmed.



Real screen with changed colors. In yellow points in alarm condition and in red points in trip condition. Colors may remain even if temperatures have dropped below programmed values if the «Clear Indication» option is selected for «After Reset»

MAIN SCREENS FOR OPERATION

5-FAILS



FAILS AF1 to Af7:

There are 7 screens paged by the >> and << keys.

AF1 to AF1: Screen Index.

Indicate the currently active faults (Alarm and Trip) if selected in the programming menu. Screens 6 and 7 indicate faults for specific sensor groups as programmed for the appropriate groups in the menu.

The **Mute Alarm** and **Reset Fail** Buttons on each screen allow you to silence the alarm (digital alarm output) or Reset the fault, respectively. Note that to reset the fault it is necessary to mute it first and also that the fault no longer exists if the 'Reset On Fail' parameter is not enabled in the Programming menu.

They also show the conditions: Alarm State Active and Trip State Output.

Fail Active, Alarm Unacknowledged and Alarm Uncleared: as detailed in screen MS1

MAIN SCREENS FOR OPERATION

6a- TRENDDINGS

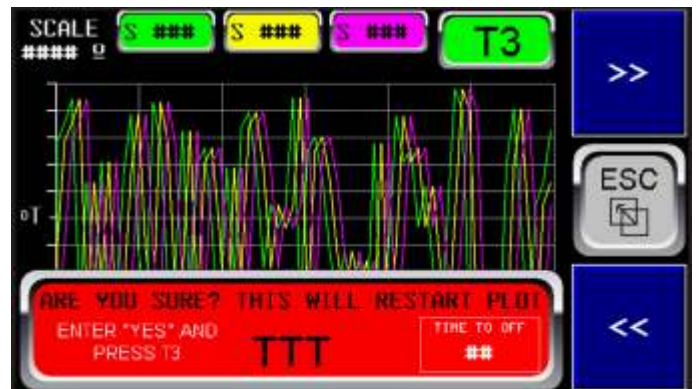
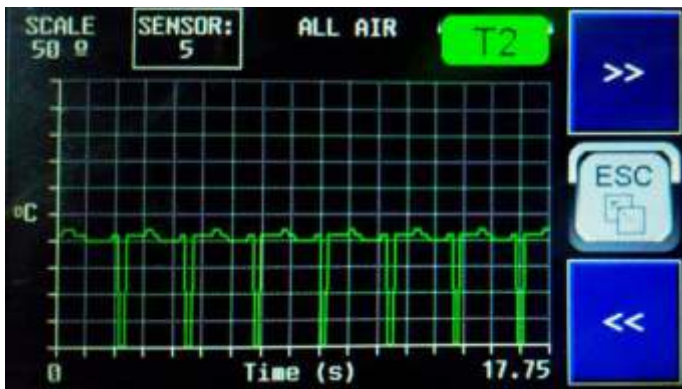
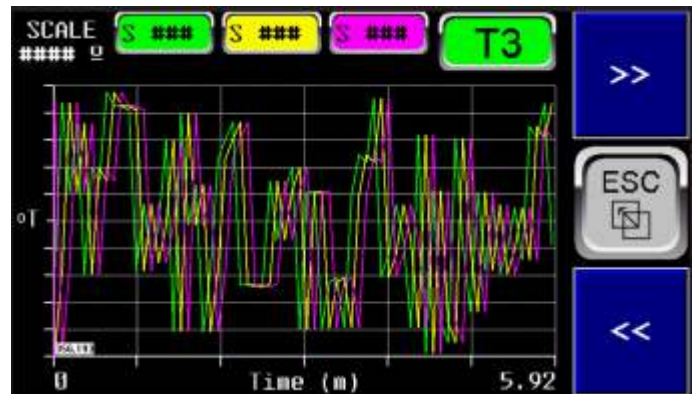
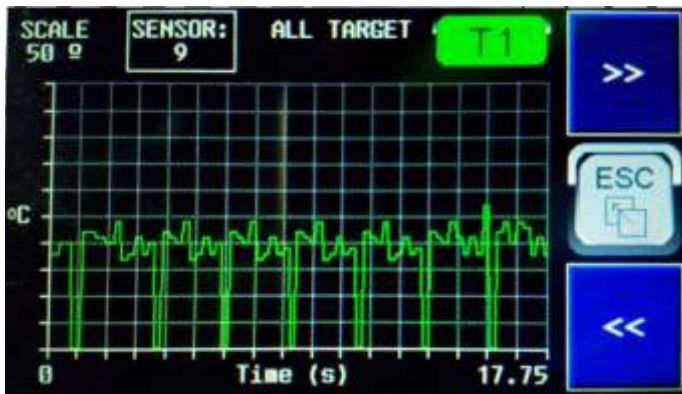

TRENDDINGS T1 and T2 (Continuous Scope):

There are 18 screens paginated by the >> and << keys. These are the first two.

T1 and T2: Display Index and curve reset button (Plot reset) if programmed to be active in the programming menu.

The first two show all the temperatures of Target and Air respectively, of the sensors programmed in the network. With each 'scan' of all temperatures the curve repeats this continuously as if it were an electrocardiogram. The "scan" never stops and the curve is continuously shifted to the left. The sampling time is 50 mS and each screen can show 17.75 seconds. When leaving this screen and coming back, the curves restart, unlike the curves from T4 to T18.

TRENDDINGS T3 (Continuous Scope):

This is the third screen of the 18 plot screens, paginated by the >> and << keys.

T3: Display Index and curve reset button (Plot reset) if programmed to be active in the programming menu.

In this screen, the indexes of 3 sensors can be entered, from 1 to 125, if entering «0» (Zero) the trace remains zero. With each 'scan' the curve goes down to zero and repeats this continuously as if it were an electrocardiogram. The "scan" never stops and the curve is continuously shifted to the left.

The sampling time is 1000 mS and each screen can show 5.92 minutes in total. When leaving this screen and coming back, the curves restart, unlike the curves from T4 to T18.

When pressing the T3 key, the button appears in red, asking if you are sure you want to restart the curves on this screen. If yes, the operator will have 10 seconds to enter the answer «Yes» in the button and touch T3 again. Otherwise, the red button disappears and the curves are not reset.

MAIN SCREENS FOR OPERATION

6b- TRENDSINGS

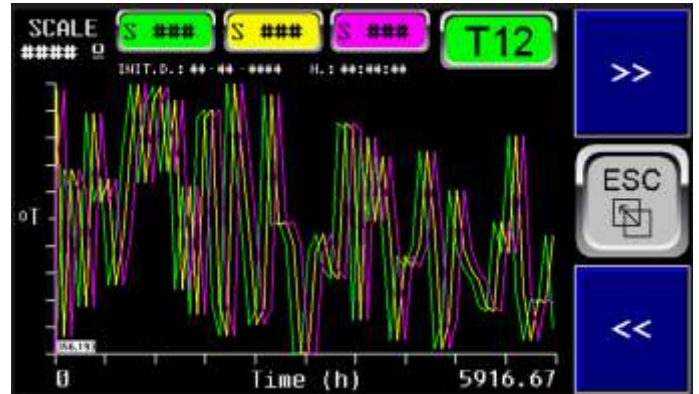
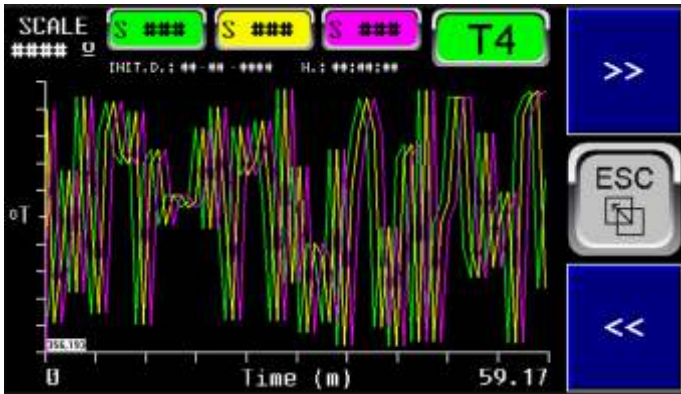

TRENDSINGS T4 to T12 (Trending Plot):

These are screens 4 to 12 of the 18 screens paged by the >> and << keys.

T4 to T12: Display Index and curve reset button (Plot reset) if programmed to be active in the programming menu. Screens T4 to T12 show 3 sensors each, selected on the screen itself using the S keys (or in the programming menu) and each screen has different reading time bases (See Table). These Screens do not automatically restart reading when exiting them, they are functional even if they are not shown and show the curves when returning for them. However, when the screen is finished, the trace does not remain inactive but always shows the memorized traces even if the relay is turned off and on again.

At the top, the date and time of the start of the plot is shown in each of the screens independently of the others.

To reset touch buttons T4 to T12.

When pressing keys T4 to T12, the button appears in red, asking if you are sure you want to restart the curves on this screen. If yes, the operator will have 10 seconds to enter the answer «Yes» on the button and touch T4 to T12 again. Otherwise, the red button disappears and the curves are not reset.

If the red button is counting down for 10 seconds and if you exit the screen, it is automatically extinguished as well.

Screen	Sampling Time	Screen Cycle
1 / 2	50 ms	17,75 s
3 / 8	1000 ms	5,92 m
4 / 9	10 s	59,17 m
5 / 10	100 s	591,67 m
6 / 11	1000 s	5916,67 m
7 / 12	1000 m	5916,67 h
13	50 ms	17,75 s
14	1 s	355 s
15	10 s	59,17 m
16	100 m	591,67 h
17	1000 m	5916,67 h
18	10 s	59,17 m

MAIN SCREENS FOR OPERATION

6c- TRENDSINGS

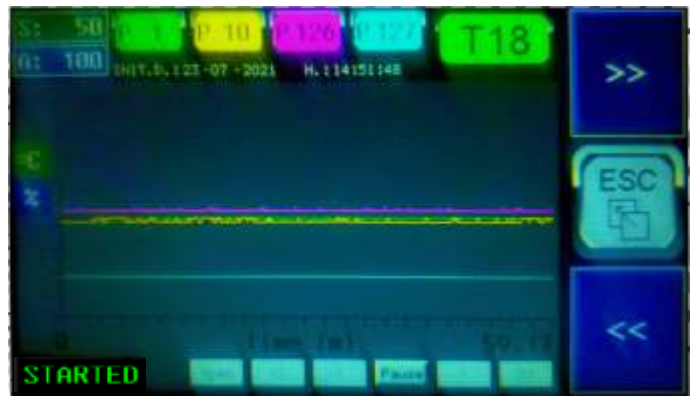
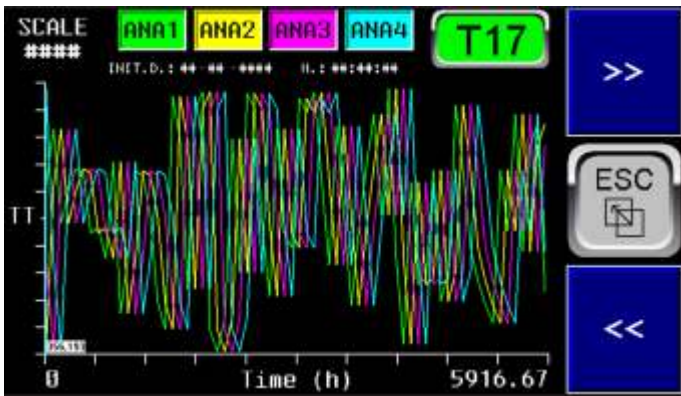

TRENDSINGS T13 to T17 (Trending Plot):

These are screens 13 to 17 of the 18 screens paged by the >> and << keys.

T13 to T17: Display Index and Curvature Reset button (Reset Plot) if programmed to be activated in the programming menu.

The different screens from T13 to T17 show 4 curves each, corresponding to the 4 analog inputs, with comparison times (See Table).

On the X axis, it is counter whether the scale is in temperature (°C or °F or percentage %).

These changes are not shown to be automatically reset when exiting them. However, when the tracing is finished, it does not continue to remain inactive, but even so, without having finished the screen, the and reconnect memorized and reconnect.

At the top regardless of the other screens displayed and start time on each of the screens in the screen.

If the power is disconnected and reconnected, it does not lose the previous reconnection and the new one is separated by a vertical black.

To touch the T17 buttons.

When pressing keys T13 to T17, the button appears in red, here you can be sure that you want to keep the curves of the screen. If yes, the operator will have 10 seconds to enter the answer «Yes» on the button and touch T13 to T17 again. Otherwise the red button will disappear and the curves will not be reset.

If the red button is counting down for 10 seconds and if you exit the screen, it is automatically extinguished as well.

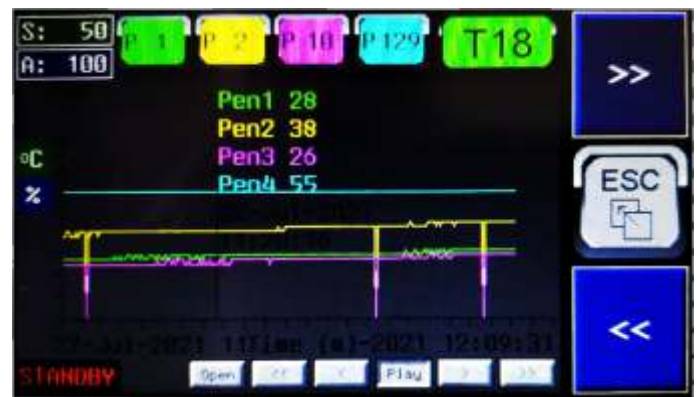

TRENDSINGS T18 (Retentive Trending Plot):

It is screen 18 of the 18 screens paged by the >> and << keys.

This feature allows the recording of curves and data plotted on the same on the memory card of up to 32 Gb inserted in the appropriate slot on the relay.

When initialized in the programming menu, the screen will display in the lower left corner the information in green letters of «**STARTED**» or «**INITIATED**» and a file folder will be automatically created on the card with the name Plotzxx where xx is the end of the current no. If it does not start, the message will be «**STANDBY**».

When in «**Started**», every hour a new file with csv extension will be created, inside this file, with the name composed of the day, month and full hour, without the minutes. Each file contains data denoted by commas, which can be opened in Excel using the «**Get data**» function within the «**Data**» tab and graphs can be generated. Each file is automatically saved hourly and will contain 360 readings of each of the 4 variables (4 dashes). Each reading is taken every 10 seconds. These are lightweight files of approximately 18 Kb each. Even if you exit the screen, recording continues and if recording is interrupted by power off and on again, a vertical black line appears at this point and recording continues.

MAIN SCREENS FOR OPERATION

6d- TRENDS

In the upper left corner, the two scales are shown, for sensor target temperatures in Green and analog inputs in Blue.

In the vertical Y axis, the two corresponding units are shown, being °C in green for the sensors and % or ° for the analog inputs, depending on what is programmed in the programming menu for them.

In the upper right corner is the screen index (T18). This button does not provide the Reset or restart of the curve and if pressed, it indicates with a phrase to enter the programming menu, turn this feature **off** and **on** again to restart the curves. This is done for safety so as not to inadvertently lose memorization.

The recorded curves can be redone on the screen by the relay itself too, to be examined. While they are being redisplayed, the user can swipe the screen and move the cursor (a vertical black line). For each point, the index of each trace and the corresponding value are displayed, with the appropriate colors equal to the traces, in addition to the date and time of recording.

At the bottom are the playback control keys, as follow.
«Pause» or **«Play»** If it is showing «Pause» the operation is effectively in Play and the curves are being generated and plotted in real time and when pressed it changes to «Play» and the operation is effectively in Pause and the curves shown are the pre-recorded ones, taken from the memory card. That is, the button actually shows the state it will enter when pressed.



«<<» This button allows you to search for the first recorded curve from the file within the date and time range selected in the Open button.

«>>» Same as above. This button allows you to search for the last recorded curve in the file.

«<» and «>» as above, allow you to search the recorded sequential curves one by one in the sequence.

«Open» button that allows selecting a time interval for the curves to be retrieved, by date and time, when informing in the window that opens the start date and time and the end date and time of the period of interest, to restrict the number of curves to be paged by the above search keys and make them easier to find.

Below we see an example of the Plot file structure on the card.

Nome	Data de modificação	Tipo	Tamanho
081809.CSV	18/08/2021 09:55	Arquivo de Valo...	11 KB
081213.CSV	12/08/2021 13:57	Arquivo de Valo...	16 KB
081212.CSV	12/08/2021 12:59	Arquivo de Valo...	18 KB
081211.CSV	12/08/2021 11:59	Arquivo de Valo...	18 KB
081210.CSV	12/08/2021 10:59	Arquivo de Valo...	16 KB
081209.CSV	12/08/2021 09:50	Arquivo de Valo...	14 KB

	A
1	Date,Time,Pen1,Pen2,Pen3,Pen4
2	19-08-2021,10:00:03 AM,000052,000056,000000,000000
3	19-08-2021,10:00:13 AM,000052,000056,000000,000000
4	19-08-2021,10:00:23 AM,000052,000056,000000,000000
5	19-08-2021,10:00:33 AM,000052,000056,000000,000000
6	19-08-2021,10:00:43 AM,000052,000056,000000,000000
7	19-08-2021,10:00:53 AM,000052,000056,000000,000000
8	19-08-2021,10:01:03 AM,000052,000056,000000,000000
9	19-08-2021,10:01:13 AM,000052,000056,000000,000000
10	19-08-2021,10:01:23 AM,000052,000056,000000,000000
11	19-08-2021,10:01:33 AM,000052,000056,000000,000000

MAIN SCREENS FOR OPERATION

7-TARGET ALARM, 8- TARGET TRIP, 9- AIR ALARM, 10- AIR TRIP

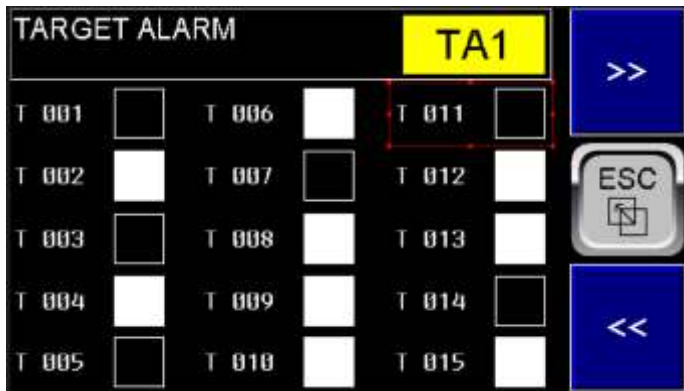

TARGET ALARM TA1 to Ta9:

There are 9 screens paged by the >> and << keys.

TA1 to TA9: Screen Index. Flashes if any of the Target values are above the programmed alarm value.

T001 to T125 (from screens TA1 to Ta9): Indicates whether the temperature of each Target(Target) is above the programmed alarm value.

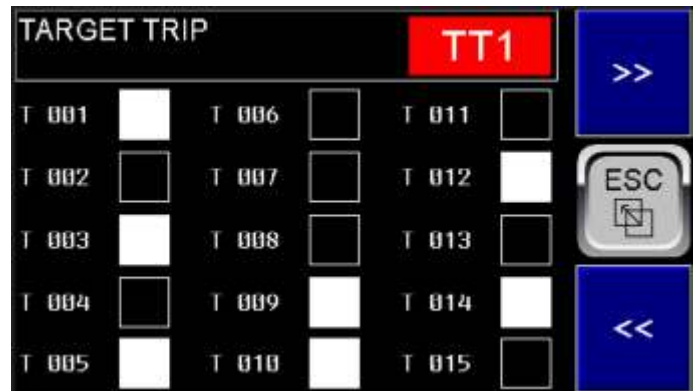

TARGET TRIP TT1 to Tt9:

There are 9 screens paged by the >> and << keys.

TT1 to TT9: Screen Index. Flashes if any of the Target values are above the programmed Trip value.

T001 to T125 (from screens TA1 to TA9): Indicates whether the temperature of each Target is above the value programmed for Trip.

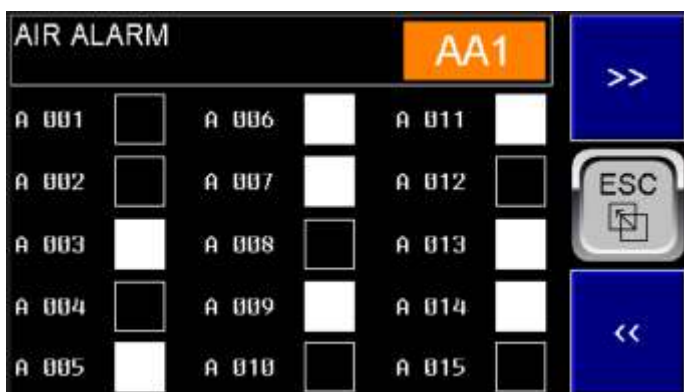

AIR ALARM AA1 to Aa9:

There are 9 screens paged by the >> and << keys.

AA1 to AA9: Screen Index. Flashes if any of the Air (Body) values are above the programmed alarm value.

A001 to A125 (from screens AA1 to AA9): Indicates whether the temperature of each Air (Body) is above the programmed alarm value.

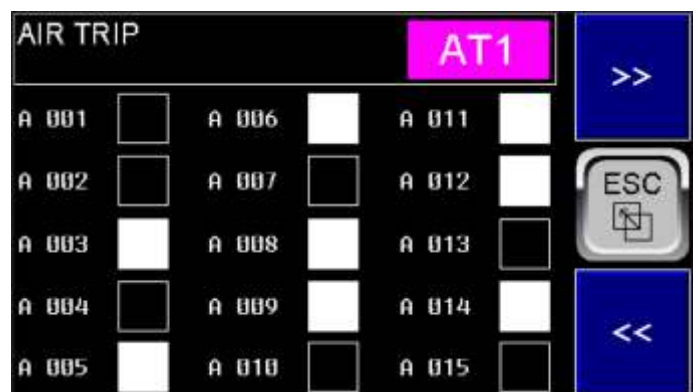

AIR TRIP AT1 to At9:

There are 9 screens paged by the >> and << keys.

AT1 to AT9: Screen Index. Flashes if any of the Air (Body) values are above the value programmed for Trip.

A001 to A125 (from screens AT1 to AT9): Indicates whether the temperature of each Air (Body) is above the value programmed for Trip.



Real Screen with Target Alarm indication. These indications are only deactivated after Reset even if the «Clear Indication» option is selected to «Auto»

MAIN SCREENS FOR OPERATION



11- NOT RESPONDING, 12- DIFFERENTIAL



NOT RESPONDING NR1 to NR9:

There are 9 screens paged by the >> and << keys.

NR1 to NR9: Screen Index.

S001 to S125 (from screens NR1 to NR9): Indicates whether the respective sensor has stopped responding to the relay on the network. Indication only occurs after 2, 3 or 4 scans of all sensors, as selected in the corresponding menu.



THM SENSORS VOLTAGE LEVEL TV01 to TV05:

There are 5 screens that can be scrolled by pressing the >> and << keys.

V001 to V100 (screens TV01 to Tv04): Shows the power supply voltage reaching each THM sensor via the communication network with shielded cables and mini USB connectors. Note that there are 3 factory-set voltage levels, which are shown in 3 different colors: Green if it is within the optimal range (Nominal is 24 VDC, but much lower voltages are allowed), Yellow if it is within an acceptable range in which stable operation is safe or Red if the voltage is below a safe level for operation.

Note that since the communication network can have different lengths, depending on the cabling used by each user, the sensors that are further away from the V5CON) device (Interface) and therefore from the power supply may have a greater voltage drop in the wiring. In this case, the user simply needs to divide the network into more than one branch, since this is possible because the sensors are in parallel and as many branches as necessary can be used for better distribution in the cubicles of each MCC or Switchgear, using the accessory device code ZTA. It is also possible to supply power from both ends of the network. See wiring suggestions in the chapter "Typical Interconnections" earlier in this manual.

In this way, by observing the voltage at each sensor, the user can be sure that the network is operating under safe conditions and it also serves to demonstrate that the sensor is communicating correctly, since it transmits voltages in the same way that it transmits temperature information (and arc-flash depending on the type).

A fourth color, Violet, shows that the sensor is not responding and the voltage indicated in the sensor voltage field will be 0.00.

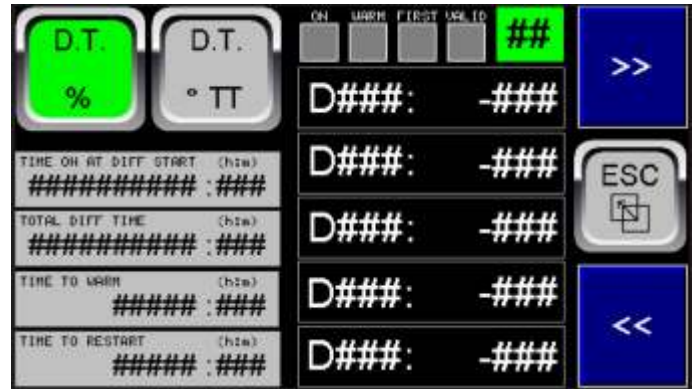

DIFFERENTIAL 1 to 21:

There are 21 screens paged by the keys of >> and <<

When activated, the sensor indexes are paged 5 to 5 from D1 to D125 and the other fields remain on the screen.

(1) to ## (9): Screen Index.

DT%: Button that selects to show the values in percentage of variation in the programmed time. When selected, it changes color from gray to green.

TEMP (°TT): Button that selects the option to show the values in differential temperature variation in the programmed time. When selected, it changes from gray to green. °TT shows whether it is in Centigrade or Fahrenheit.

ON: Indicator that the system has initiated the differential function (if programmed to do so in the programming menu).

WARM: Indicates that the programmed heating period has already passed, during which the system disregards the readings to calculate the differential variation, waiting for the system to stabilize in a normal operating temperature condition.

FIRST: Indicates that the first reading was performed, after the 'Warm' period, on which the differential variations for each new reading will be calculated

VALID: Indicates whether the new reading is valid for differential calculations.

TIME ON AT DIFF. START: Shows for information the time in 'On' in hours and minutes since the system was started, according to screen 2 of the information screens.

TOTAL DIFF. TIME: Shows the total time since the first valid reading was performed and over which the differential is calculated.

TIME TO WARM: Displays a countdown to zero of the time remaining to complete the «Warm» period as programmed.

TIME TO RESTART: (only appears if set to "Valid") Displays a counter back to zero of the time remaining in hours and minutes, for automatic resetting of a new differential period, if programmed for this in the programming menu. If not programmed for automatic restart, the system remains indefinitely considering the first reading taken after Warm. If it is restarted, manually or automatically, when the system is already in a stable condition (after Warm), a new Warm period is not expected and a new initial reading is performed for future differential calculations. While the differential calculation is not started, after Warm, this field is shown as 0:0

D### to D###: Sensor indices from 1 to 125 if the system is operating with active and valid differential, otherwise D0 is shown in all 5 fields.

###: Differential value in % or temperature (°C or °F) for each index from D1 to D125, as selected on the % or Temp selection buttons. described above. This value is white if it is below the differential value programmed for alarm or yellow if it is above the differential level programmed for Trip. In both cases it also flashes in addition to changing color.

MAIN SCREENS FOR OPERATION

13- FLASH, 14- ALARM, 15- HISTORY

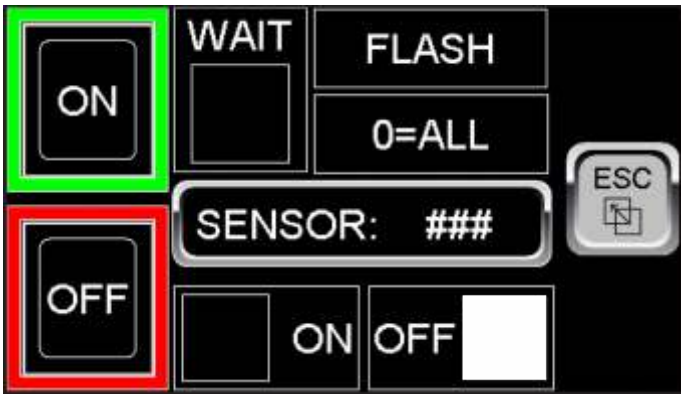

ON OFF FLASH SENSOR SCREEN:

It is a screen where you can command the change of the LED flashing pattern on the back of each sensor to facilitate its identification on the network.

In the current system configuration, each Sensor has a LED on the back that flashes continuously while it is active and communicating with the relay. In older configurations, the LED may be on continuously and start blinking when commanded.

Despite being identified as Flash, in the current system, when this ON action is commanded, in a sensor it stops blinking, staying **On** continuously. When commanding the OFF action, it returns to the normal state, flashing continuously. The opposite occurs in older systems.

This command can be executed with the system operating normally.

Each sensor on the network has an address from 1 to 125 as programmed at startup by a computer with the Zyggot management system installed. To facilitate future identification for possible system maintenance, this effect can be commanded.

ON: Flash ON button.

OFF: Flash OFF button.

WAIT: Indicates to wait for the end of a reading cycle to command Flash.

SENSOR: Button where you can enter the sensor number from 1 to 125. If 0 is entered, all the sensors in the network will carry out the Flash command (it is used to check if all the sensors responded and recognized the command, thus being integrated).

ON: Indicates that one or all sensors have the Flash command active.

OFF: Indicates that no sensor has the Flash command active.

If you try to exit the Flash screen with an active sensor, a screen with the phrase «TURN OFF FLASH BEFORE EXIT»

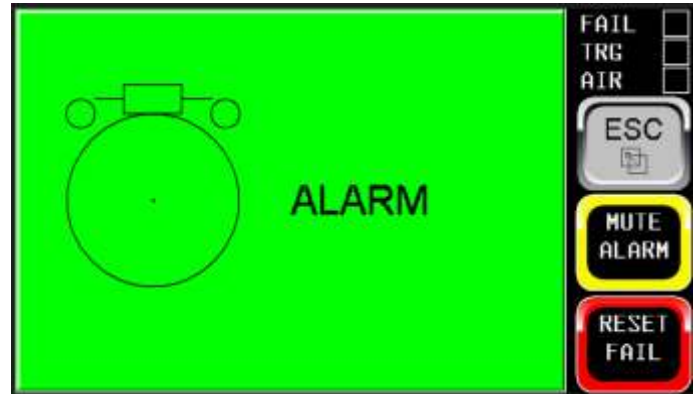

ALARM SCREEN:

ALARM: It is a screen where you can check all the Alarms, Faults and events that have occurred, with date and time (Time Stamp), in addition to being able to recognize them (Acknowledge) or (ACK) or clear them (Clear). To do this, touch any point on the Alarm screen that is green in the normal condition or Red in the condition of activated and unacknowledged (ACK) or clear (CLR) faults or Yellow if there are faults with ACK but not Clear.

Fail: Indicates on this screen that there is an active fault that has not been reset.

TRG: Indicates on this screen that there is a failure related to Target.

AIR: Indicates on this screen that there is a fault related to Air.

MUTE: Alarm mute button. Turn off the alarm output.

RESET: Fault Reset Button. Only works after Mute.



HISTORY SCREEN:

HISTORY: It is a screen where you can check all the events that have occurred, with date and time (Time Stamp), but you cannot recognize or clean them. There is another screen for this, accessed from within the programming menu. Tap anywhere on the History screen.

Memorized events include the Ack and Clear action performed on the Alarm Screen above in addition to the inactivation of the fault that has occurred (Return).

The other fields are like the ones on the Alarm screen above.

MAIN SCREENS FOR OPERATION

16- PROGRAM REPORT

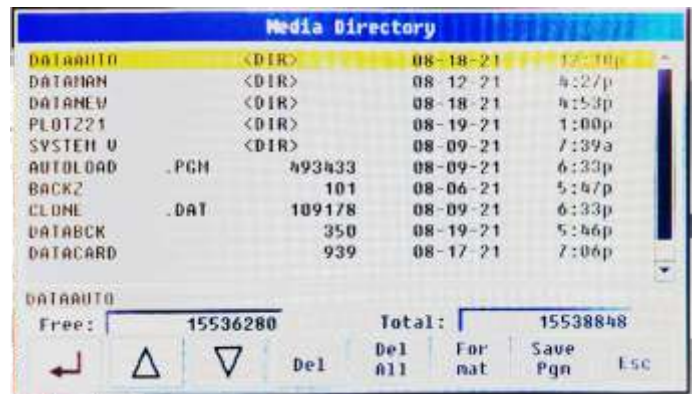
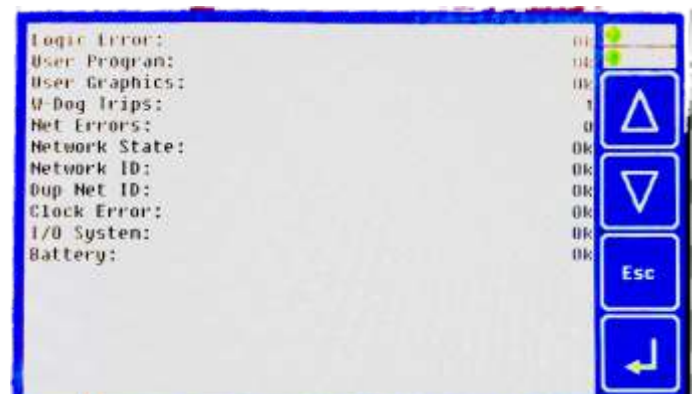

PROGRAM REPORT SCREEN 1 to 5:

There are 5 screens that reproduce the Programming Menu and two more system information screens, where you can check the various programming conditions without being able to change the programming inadvertently. Note that the two system screens do not allow any data changes since it is a condition of viewing the existing files only and not programming. The screen that shows the directories despite presenting alteration commands, they will not work for security reasons. The user can however open the files on the computer and make readings and changes but should refrain from altering the root files as this could compromise the operation. Files inside directories can be changed or deleted freely without risk. See details of the following parameters on the Programming Menu screens.

MAIN SCREENS FOR OPERATION

17- ETHERNET REPORT

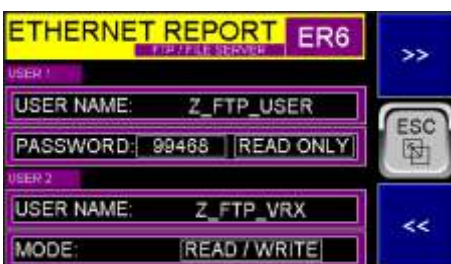
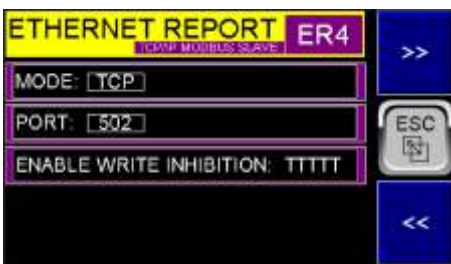
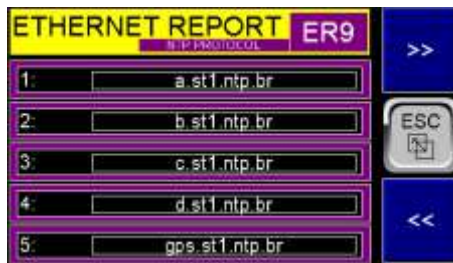
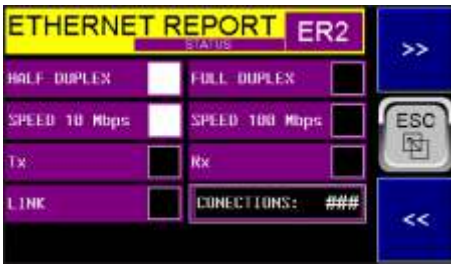
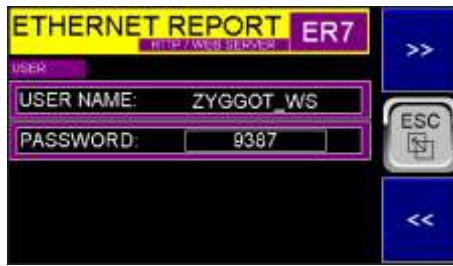
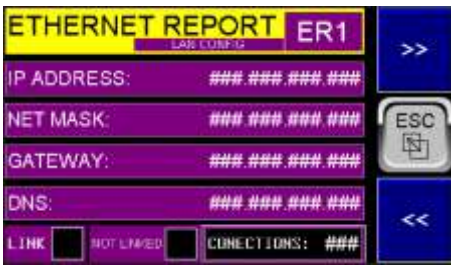

ETHERNET REPORT SCREEN 1 a 9:

There are 9 screens that reproduce the Ethernet Programming Menu, where you can check the different programming conditions without being able to change the programming inadvertently. None of the screens allows commands or changes, with the exception of the **ER3** screen, where you can choose an address and command a **PING** action to check if a certain network equipment is responding.

Further on, the fields of all these screens will be detailed. Here we will only comment on the function of each of them.

Screens **ER1** and **ER2** refer to the main Ethernet configuration parameters. On the **ER1** screen are the parameters and on the **ER2** screen are the Connection Status.

Screen **ER3** refers to the **ICMP protocol - Internet Control Message Protocol** and it is possible to Ping with the address of a certain device.

The **ER4** screen refers to the **TCP/IP - Transmission Control Protocol (Modbus TCP Server or Modbus Slave)**. Through this protocol, Modbus Over Ethernet communication can be carried out, using all the parameters and addresses described in the Modbus Map at the end of this manual. The **ER5** screen refers to the **IP protocol - Internet Protocol (Ethernet IP Server)**.

The **ER6** screen refers to the **FTP - File Transfer Protocol**. Through which it is possible to read and have access to the files of the memory card inserted in the respective slot of the relay and where the temperature readings, etc., are recorded through a Browser.

The **ER7** screen refers to the **HTTP protocol - Hypertext Transfer Protocol**.

The **ER8** screen refers to the **ASCII Over TCP/IP - ASCII Transmission Control Protocol**.

The **ER9** screen refers to the **NTP protocol - Network Time Protocol** through which precise times can be obtained from pre-defined NTP servers.

PROGRAMMING

16a- MENU

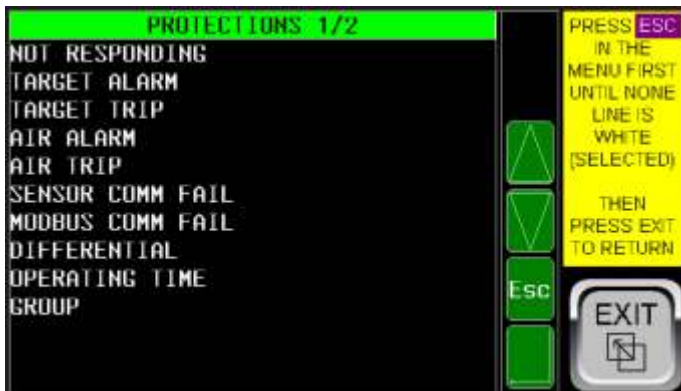
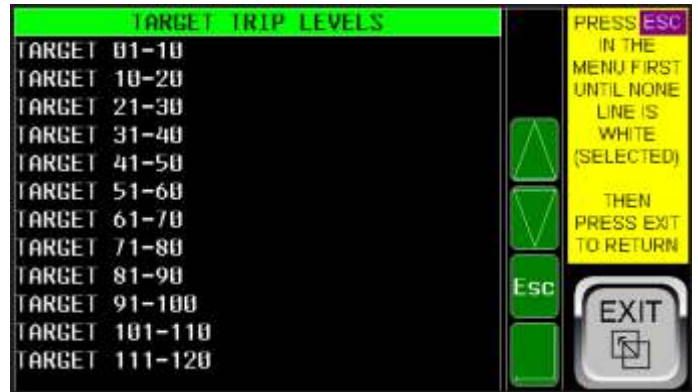

In the “Programming Menu” MAIN (Main) 13 Sub-items or Sub-menus are available, namely:

- M01:** Relay Config.
- M02:** Parameters Cfg.
- M03:** Sensors.
- M04:** Block Programming.
- M05:** Analog Inputs.
- M06:** Modbus Cfg.
- M07:** Protections.
- M08:** Target Alarm Levels.
- M09:** Target Trip Levels.
- M10:** Trending Config.
- M11:** Clear Data
- M12:** Backup/Restore Data
- M13:** Ethernet configuration

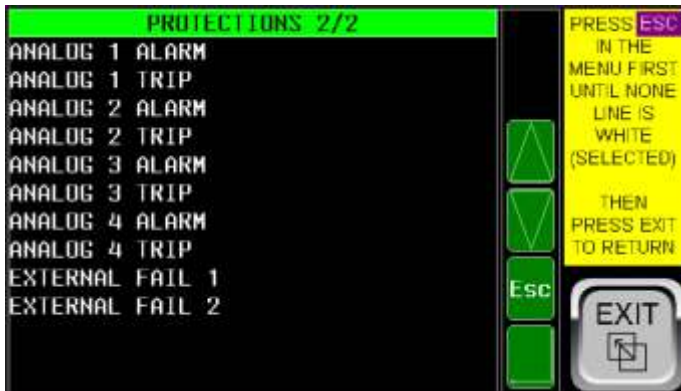

Since sub-item 4 is subdivided, namely:

- M04:** Block 1
- M04:** Block 2
- M04:** Block 1
- M04:** Block 2
- M04:** Do Block Programm

And sub-item 7 is subdivided into two others, namely:

- M07:** Protections 1/2
- M07:** Protections 2/2

And sub-item 8 is subdivided into 10

- M8:** Target 01-10 to **M8:** Target 11-120

And sub-item 9 is subdivided into 10

- M9:** Target 01-10 to **M9:** Target 11-120

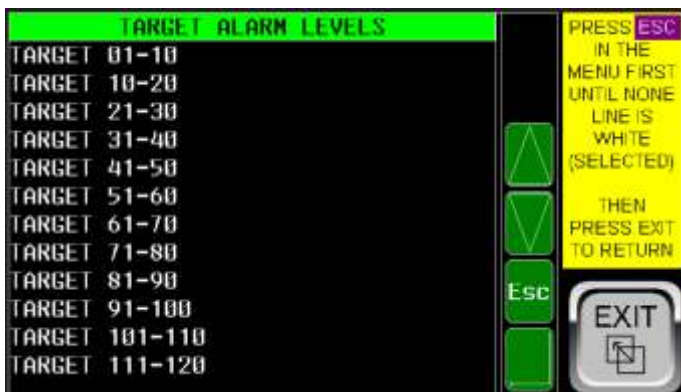

PROGRAMMING

16b- MENU

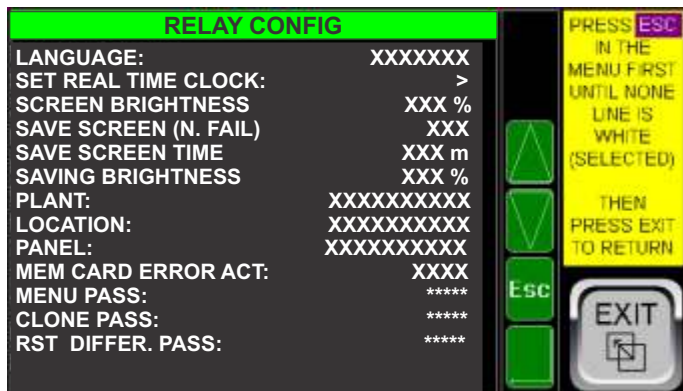

M01-RELAY CONFIG

- 01.1- Language:** (English, Portuguese, Spanish).
- 01.2- Set Real Time Clock:** Enter correct date and time if necessary.
- 01.3- Screen Brightness:** Adjust the screen brightness between 50 and 100% for normal operating condition.
- 01.4- Save Screen (N. Fail):** Select «Yes» to start reducing the screen brightness after the time programmed below or «No» to not perform this action. Will not perform this action if it is at fault. (N. Fail). And if it is in “Screen saver” and failure occurs, the screen will return to its normal brightness until the failures are reset.
- 01.5- Save Screen Time:** Adjust the screen's inactivity time so that it has reduced brightness. When touching the screen, the brightness returns to normal and this time is counted again.
- 01.6- Saving Brightness:** Adjust the screen brightness between 0 and 50% for the screen saving condition.
- 01.7- Plant:** Enter the description of the Plant with a maximum of 10 letters.
- 01.8- Location:** Enter the location description of the facility with a maximum of 10 letters.
- 01.9- Panel:** Enter the description of the panel with a maximum of 10 letters.
- 01.4- Mem Card Error Act:** (None, Log). Select None if you do not want the Card Error Alarm to occur or Log if you want the fault to occur.
- 01.10- Menu Pass:** Enter the new Password if necessary, with a maximum of 5 numbers. If set to zero, the programming menu can be accessed by the operator without a password, which entails a risk and is not advisable.
- 01.11- Clone Pass:** Enter a new Password if necessary, with a maximum of 5 numbers to access the Relay Clone menu.
- 01.12- RST Differ. Pass:** Enter a new Password if necessary, with a maximum of 5 numbers to access the Restart Differential Data menu. This request is made to the operator each time the relay is reconnected with active differential data. You can start a new differential cycle from this moment or keep the initial readings of the currently valid differential system.

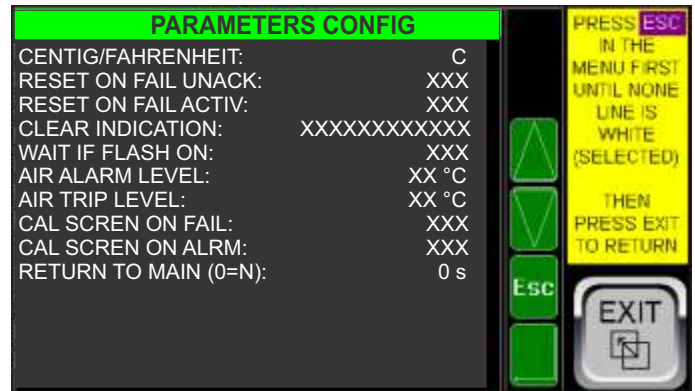

M02- PARAMETERS CFG

- 02.1- Centig/Fahrenheit:** (C or F). Choose the Temperature unit.
- 02.2- Reset On Fail Unacknowledged:** (Yes, No). Choose **Yes** to enable Unacknowledged Fault Reset (Ack). Fault acknowledgment is done on the Alarm screen. It is flashing and with a red border in case there is no Acknowledged alarm.
- 02.3- Reset On Fail Uncleared:** (Yes, No). Choose **Yes** to enable Reset with unrecognized fault cleared or reset (Clr). Fault reset is done on the Alarm screen. It flashes and has a red border if there is a non-Cleared alarm.
- 02.4- Wait if Flash On:** (Yes, No). Condition to return to the main screen automatically, as explained in the parameter «Return to Main» further on. If you select «Yes», it will not automatically return to the main screen if you have Flash On.
- 02.5- Clear Indication:** (Auto, After Reset). If “Auto” is chosen, the yellow and red color indications on the main temperature screens return to white if the temperature returns to a value below the alarm or trip point, but the squares indicating Alarm or Trip remain on until the button is pressed. «Reset». If «After Reset» is chosen, the yellow and red colors continue to indicate an alarm or trip that has occurred even if the temperatures have returned to normal, as well as the little squares remain active. The colors and fault indicators only return to normal after «Reset» is activated. This is the factory condition and is safer to indicate temperature faults that have already returned to normal conditions.
- 02.6- Air Alarm Level:** Alarm level for air or sensor body (air). Valid for all sensors.
- 02.7- Air Trip Level:** Trip level for air or sensor body. Valid for all sensors.
- 02.8- Cal Screen On Fail:** (Yes, No). If set to «Yes», in case of trip failure, the alarm screen will be automatically shown.
- 02.9- Cal Screen On Alarm:** (Yes, No). If set to «Yes», in the event of an Alarm, the alarm screen will be automatically displayed.
- 02.12- Return to Main:** Time in seconds after which the relay will automatically show the main screen 1. If set to zero, there will be no automatic return. There will also be no automatic return if you are in programming menu screens or with Flash activated according to parameter 02.5 above.

PROGRAMMING

16d- MENU

These data files, named **Thhmm**, will have a line for each period end, chosen in item 03.5. with comma-separated data structure, from Excel, also with CSV extension.

Note that for this option, data with zeros are not inserted at each restart for marking because new files are already created at each restart, therefore this insertion is not necessary for information.

Note that as long as the relay is not reset or a «**Start New File Now**» command is not given, which is equivalent to a relay re-connection, the temperature data will be added (Appended) to the last file created **Thhmm** or **Ahhmm**, being a line for each reading, in each period, as programmed, with the same comma-separated structure of the previous files, i.e.:

dd, mm, yyyy, hh, mm, ss, 0, NS, SR, 0, T1, T2, T3 Tn
 dd, mm, yyyy, hh, mm, ss, 0, NS, SR, 0, T1, T2, T3 Tn
 being day, month, year, hour, minute, second, zero separator, Number of total sensors, Number of sensors responding, Zero separator, Temperature sensor 1, Temperature sensor 2 up to Temperature of the last programmed sensor.

In the following examples, with 10 sensors, it is possible to observe the structure of files and data for the option «**New File Each Start**»

First the structure for Targets (Target):

And then the file structure for Ar below.

Nome	Data de modificação	Tipo	Tamanho
AIR	18/08/2022 08:57	Pasta de arquivos	
TARGET	18/08/2022 08:57	Pasta de arquivos	

Nome	Data de modificação	Tipo	Tamanho
19082021	18/08/2021 16:59	Pasta de arquivos	
18082022	18/08/2022 09:08	Pasta de arquivos	
18082021	17/08/2021 09:31	Pasta de arquivos	
17082021	16/08/2021 19:12	Pasta de arquivos	

Nome	Data de modificação	Tipo	Tamanho
A1653	19/08/2021 16:53	Arquivo	1 KB
A1654	19/08/2021 16:54	Arquivo	1 KB
A1655	19/08/2021 16:58	Arquivo	1 KB
A1659	19/08/2021 16:59	Arquivo	1 KB

Nome	Data de modificação	Tipo	Tamanho
AIR	18/08/2022 08:57	Pasta de arquivos	
TARGET	18/08/2022 08:57	Pasta de arquivos	

Nome	Data de modificação	Tipo	Tamanho
17082021	16/08/2021 19:12	Pasta de arquivos	
18082021	17/08/2021 09:31	Pasta de arquivos	
18082022	18/08/2022 09:08	Pasta de arquivos	
19082021	18/08/2021 16:59	Pasta de arquivos	

Nome	Data de modificação	Tipo	Tamanho
T0927	19/08/2021 10:27	Arquivo	1 KB
T1653	19/08/2021 16:53	Arquivo	1 KB
T1654	19/08/2021 16:54	Arquivo	1 KB
T1655	19/08/2021 16:58	Arquivo	1 KB
T1659	19/08/2021 16:59	Arquivo	1 KB

Nome	Data de modificação	Tipo	Tamanho
T1653	19/08/2021 16:53	Arquivo	1 KB
T1654	19/08/2021 16:54	Arquivo	1 KB
T1655	19/08/2021 16:58	Arquivo	1 KB
T1659	19/08/2021 16:59	Arquivo	1 KB

T1655 - Bloco de Notas

Arquivo Editar Formatar Exibir Ajuda

```
19,8,2021,0,16,55,4,0,10,0,10,0,25,28,27,26,27,26,27,27
19,8,2021,0,16,56,4,0,10,0,10,0,25,28,27,26,27,26,27,27
19,8,2021,0,16,56,29,0,10,0,10,0,25,28,27,26,27,26,27,27
19,8,2021,0,16,57,11,0,10,0,10,0,25,28,27,26,27,25,27,27
19,8,2021,0,16,58,10,0,10,0,10,0,25,28,27,26,28,26,27,27
```

Nome	Data de modificação	Tipo	Tamanho
A1653	19/08/2021 16:53	Arquivo	1 KB
A1654	19/08/2021 16:54	Arquivo	1 KB
A1655	19/08/2021 16:58	Arquivo	1 KB
A1659	19/08/2021 16:59	Arquivo	1 KB

A1655 - Bloco de Notas

Arquivo Editar Formatar Exibir Ajuda

```
19,8,2021,0,16,55,9,0,10,0,10,0,25,26,26,27,26,26,25,25
19,8,2021,0,16,56,9,0,10,0,10,0,25,26,26,27,26,26,25,25
19,8,2021,0,16,56,34,0,10,0,10,0,25,26,26,27,26,26,25,25
19,8,2021,0,16,57,16,0,10,0,10,0,25,26,26,27,26,26,25,25
19,8,2021,0,16,58,15,0,10,0,10,0,25,26,26,27,26,26,25,25
```

PROGRAMMING

16e- MENU

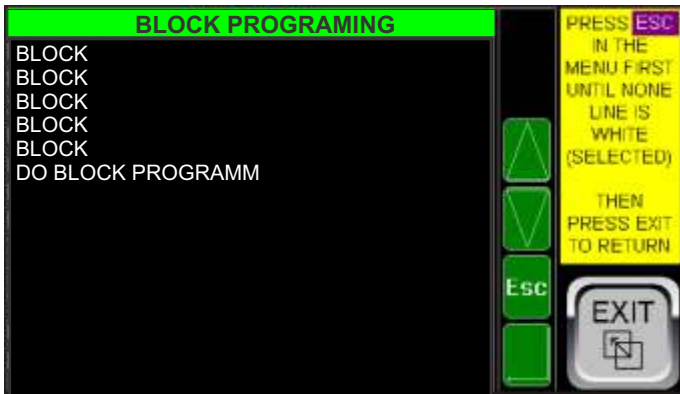

M04- BLOCK PROGRAMING

This menu allows you to more easily program the target parameters for each sensor. They can be programmed one by one with different values (see ahead) or all at the same time and with the same values if placed all in the same block, or in up to 5 blocks with different values for each block.

M04.1- BLOCK 1 (same for blocks 2, 3 and 4)

04.1.1- Start: (1 to 125). Starting sensor number of this block.

04.1.2- End: (1 to 125). Final sensor number of this block.

04.1.3- Target Alarm: xxxx °. Centigrade or Fahrenheit, depending on the programming, above which the Alarm will be activated (and not Trip, which is the next level).

04.1.4- Target Trip: xxxx °. Centigrade or Fahrenheit degrees, depending on the programming, above which the Trip will be activated (and also the Alarm, since if the Trip signal is activated automatically, the Alarm signal will also be activated. The opposite does not occur. If only the Alarm level is reached, Trip will not be triggered and the corresponding fault actions selected in the fault menus will be triggered.

M04.2- BLOCK 2 - ditto blocks 1

M04.3- BLOCK 3 - ditto blocks 1

M04.4- BLOCK 4 -ditto blocks 1

M04.5- DO BLOCK PROGRAM

After inserting all the parameters of the blocks (or just one block with all the sensors), select this submenu and you will be taken to the screen that will execute the automatic programming when confirming the «Proceed?» button with the «Yes» option.

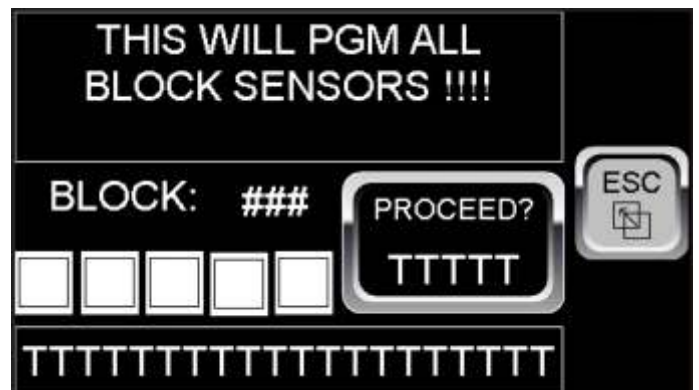

PROGRAMMING

16f- MENU

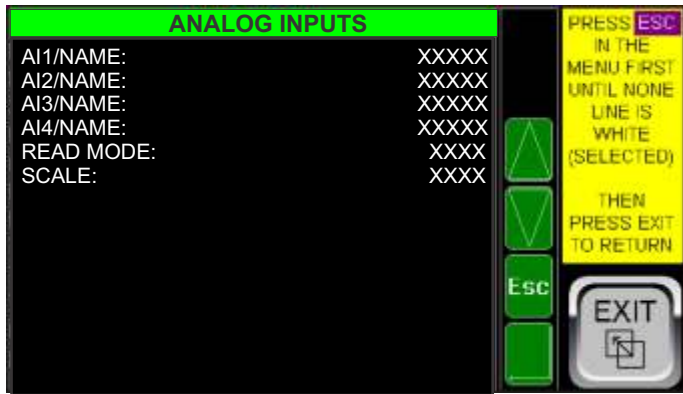

M05- ANALOG INPUTS

05.1- AI1/NAME: Enter the name of the analog input, with up to 5 characters, to facilitate its identification.

0.5.2-AI2/NAME: Ditto.

0.5.3-AI3/NAME: Ditto.

0.5.4-AI4/NAME: Ditto.

0.5.5-Read Mode: (% , Temp). Reading mode and shows on the screens, in percentage in relation to the end of scale (5V) or Temperature. The next parameter defines the end of scale for the temperature.

05.5.6- Scale: xxxx. enter the temperature that is equivalent to the end of scale (5V) of the analog inputs.

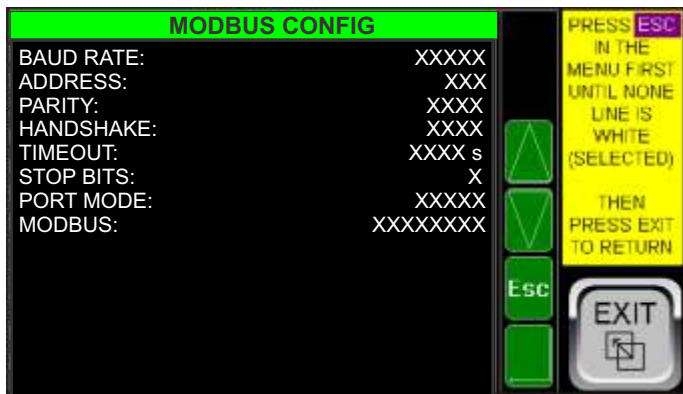

M06- MODBUS CONFIG

This menu is related to the Modbus communication port for the user to connect to the DCS system optionally. (It is not related to the communication port with the sensors)

06.1- Baud Rate: (9600, 19200, 38400) Enter the required Baud Rate.

06.2- Address: (1 to 247): Enter the network node address for this relay.

06.3- Parity: (None, Odd, Even). Choose the required parity.

06.4- Handshake: (None, XON/XOFF, CTS/RTS, MD/HALF), Choose the required Handshake.

06.5- Timeout: (0 to 1023 s). Enter the required Timeout.

06.6- Stop Bits: (1 or 2). Choose the required value).

06.7- Port Mode: (Rs232, Rs485). Choose the mode used.

06.8- Modbus: (Active, Inactive). To turn Modbus on or off. If not used, leave it in «Inactive».

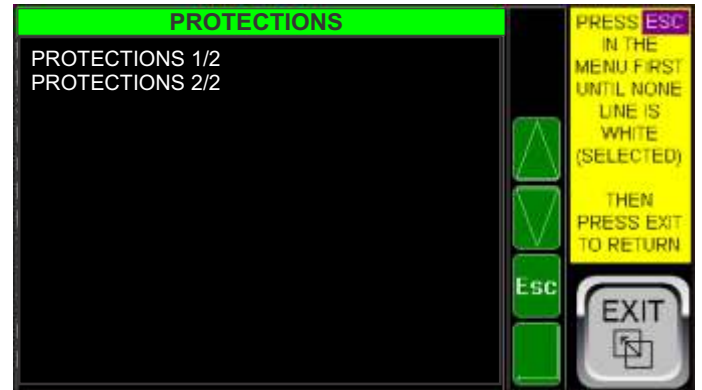

M07- PROTECTIONS

This menu is divided into two (1/2 and 2/2)



M07- PROTECTIONS 1/2

In this menu, the parameters related to the protections shown above will be programmed.

PROGRAMMING

16g- MENU

NOTE:

ACTION: The choice possibilities for the Action parameter of each of the faults can include one or more options as follows and informed in the part in parentheses of each fault described below and will not be further detailed: (**None, Log, Alarm, Trip**). In «None» this fault will not be considered. In «Log», it will be logged in the Alarm screen but the Alarm condition and output will not act. In «Alarm» the fault will be logged and the Alarm condition will act. In «Trip», the fault will be logged, the Alarm condition will activate and the Trip condition will activate.

AUX OUTPUT: The options for all faults are «None», «D.O.3», «D.O.4», «EB1:Aux1», «EB2:Aux2», «EB3:Aux3», «EB4:Aux4»..... «EB8:Aux8" This will not be detailed in each failure description below, what is described here applies to all. Note that the «D.O.1» and «D.O.2» outputs are dedicated to «Alarm» and «Trip» and the D.O.3 and D.O.4 outputs are programmable and are located in the relay while the others, also programmable, are found in the Expansion Block EBLOCK 88x.

Note: More than one fault can be assigned to the same output and it will switch if any of the faults assigned to it occur.



M07.2- TARGET ALARM

This fault will occur if one or more sensors reach the alarm temperature level for the target, programmed for each of them in the corresponding menu.

07.2.1- Action: (None, Log, Alarm). Choose option. Note that there is no «Trip» option.

07.2.2- Aux Output: (None, D.O.3, D.O.4, EB1: Aux1 to EB8: Aux8). Choose the option.



M07.1- NOT RESPONDING

This fault will occur if one or more sensors are not responding in the sensor network.

07.1.1- Action: (None, Log, Alarm). Choose the desired option.

07.1.2- Aux Output: (None, D.O.3, D.O.4, EB1: Aux1 to EB8: Aux8). Choose the desired option.

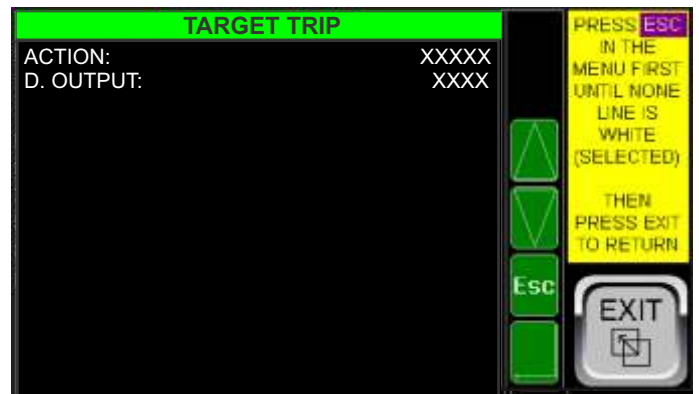

M07.3- TARGET TRIP

This fault will occur if one or more sensors reach the Trip temperature level for the target, programmed for each of them in the corresponding menu.

07.3.1- Action: (None, Log, Trip). Choose option. Note that there is no option «Alarm» which will also be activated together with Trip.

07.3.2- Aux Output: (None, D.O.3, D.O.4, EB1: Aux1 to EB8: Aux8). Choose the option.

PROGRAMMING

16h- MENU



M07.4- AIR ALARM

This fault will occur if one or more sensors reach the alarm temperature level for the air (sensor body), programmed for each one of them in the corresponding menu.

07.4.1- Action: (None, Log, Alarm). Choose option. Note that there is no «Trip» option.

07.4.2- Aux Output: (None, D.O.3, D.O.4, EB1: Aux1 to EB8: Aux8). Choose option.



M07.5- AIR TRIP

This fault will occur if one or more sensors reach the Trip temperature level for the air (sensor body), programmed for each of them in the corresponding menu.

07.5.1- Action: (None, Log, Trip). Choose option. Note that there is no option «Alarm» which will also be activated together with Trip.

07.5.2- Aux Output: (None, D.O.3, D.O.4, EB1: Aux1 to EB8: Aux8). Choose option.

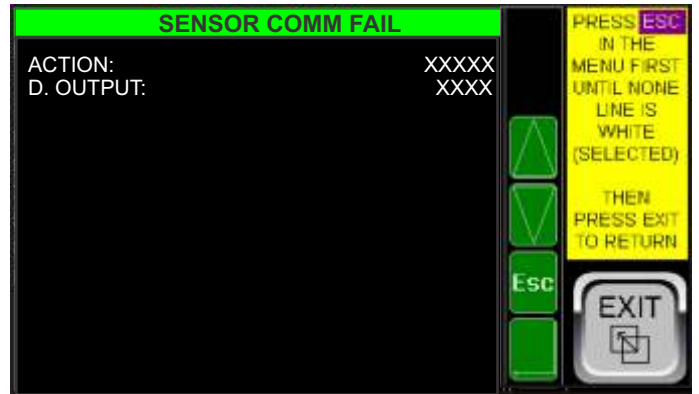

M07.6- SENSOR COMM FAIL

This fault will occur if the sensor network has a fault, which is shown on the main screen (MS6) as already described in the part corresponding to this screen and whose type of fault is shown on this screen.

07.6.1- Action: (None, Log, Alarm). Choose the desired option. Note that there is no Trip option as this is not a major fault that could trip the system and can therefore be remedied.

07.6.2- Aux Output: (None, D.O.3, D.O.4, EB1: Aux1 to EB8: Aux8). Choose the desired option.

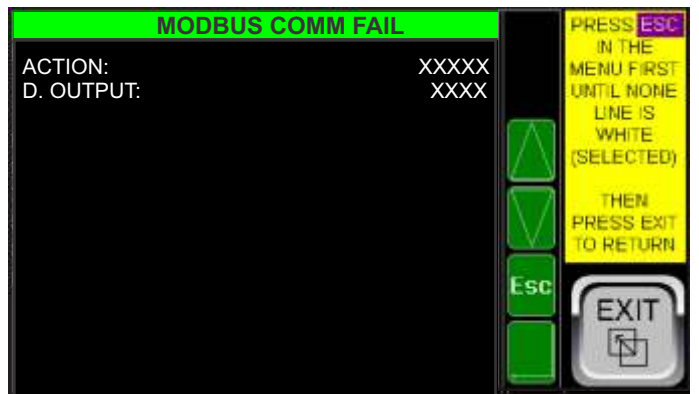

M07.7- MODBUS COMM FAIL

This fault will occur if the sensor network has a fault, which is shown on the main screen (MS6) as already described in the part corresponding to this screen and whose type of fault is shown on this screen.

07.7.1- Action: (None, Log, Alarm). Choose the desired option. Note that there is no Trip option as this is not a major fault that could trip the system and can therefore be remedied.

07.7.2- Aux Output: (None, D.O.3, D.O.4, EB1: Aux1 to EB8: Aux8). Choose the desired option.

PROGRAMMING

16i- MENU



M07.8- DIFFERENTIAL

This fault will occur if the differential fault is scheduled to run and the temperature rises from the first measurement as scheduled.

07.8.1- Execute Diff: (Yes, No). Choose «Yes» to activate this protection or «No» to not activate it.

07.8.2- Alarm Level: Enter the Alarm level as a percentage of the initial reading.

07.8.3- Trip Level: Enter the Trip level as a percentage of the initial reading.

07.8.4- Alarm Action: (None, Log, Alarm). Note that there is no Trip option.

07.8.5- Trip Action: (None, Log, Trip). Note that there is no Alarm option which will occur together with the Trip option.

07.8.6- Warm Up Hours: enter the warm up time in hours required to take the first measurement. The first measurement is made with the system warmed up and stabilized. In environments with high ambient temperature variations, do not choose a very tight alarm or trip level, taking into account the ambient temperature variation as well.

07.8.7- Restart Period: (0=No) Enter the period for automatic restart of the function, that is, to make a new measurement. The Restart can also be manual, at any time, performed in item 08.7.9 below. Note that entering zero is equivalent to never performing the automatic restart.

07.8.8- Aux Output: (None, D.O.3, D.O.4, EB1: Aux1 to EB8: Aux8). Choose the desired option.

07.8.9- Restart Differ: This item directs to the screen that will execute the differential reset (shown below), performing a new initial reading when the action on the «Proceed?» button is confirmed. with the option «Yes».



07.8.9- Restart Differential: If the green button is pressed, there will be a new reading of the initial reference temperatures for the differential after the counting of the new heating period (warm).

If the yellow button is pressed, there will be a new reading immediately, without the warm-up period. Only use the yellow button if you are sure the system is currently at a stable temperature.

This screen will also appear after the relay has been switched off, when the differential condition is valid, that is, with the indication of «Valid» so that the operator can decide whether to continue with the data previously readed and saved for the differential reference or to start the differential with a new reading. .

To keep the old data just press «ESC».



M07.9- OPERATING TIME

This fault will occur if the fault is programmed to be executed in «Action» and the time on (Time On) is longer than the programmed one. This failure serves to schedule any preventive maintenance on the system, although the Zyggot system itself does not require any preventive maintenance ever.

07.9.1- Action: (None, Log, Alarm). Choose the desired option. Note that there is no Trip option.

07.9.2- Hours: Enter the number of hours On to activate this protection (max = 250000 h).

07.9.3- Aux Output: (None, D.O.3, D.O.4, EB1: Aux1 to EB8: Aux8). Choose the desired option.

16j- MENU

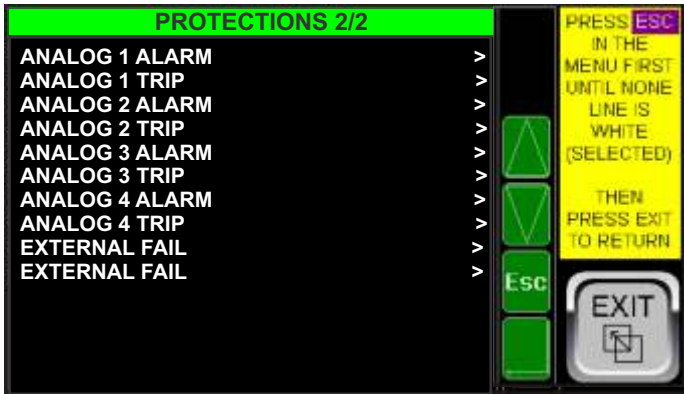

M07.11- GROUP

This menu is subdivided into 5 (Group 1 to Group 5). Only group 1 programming will be detailed. The others are identical.

M07-PROTECTIONS 1/2

In this menu, the parameters related to the protections shown above will be programmed. The numbering of the submenus will follow the sequence of the menu 7- Protections

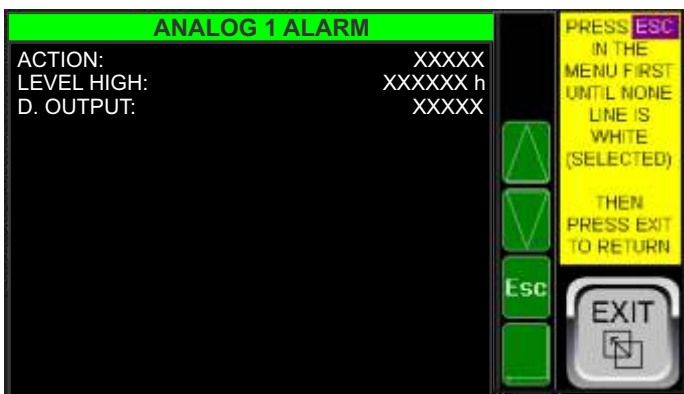

M07.11- GROUP 1

This fault will occur if any of the sensors assigned to this group are in Alarm condition or Trip condition.

M07.12-ANALOG 1 ALARM

This fault will occur if the fault is programmed to run in «Action» and the value of analog input 1 exceeds the programmed level.

07.11.1- Target Alarm Action: (None, Log, Alarm). Note that there is no Trip option.

11.07.2- Target Trip Action: (None, Log, Trip). Note that there is no Alarm option which will occur together with the Trip option.

07.11.3- Air Alarm Action: (None, Log, Alarm). Note that there is no Trip option.

11.07.4- Air Trip Action: (None, Log, Trip). Note that there is no Alarm option which will occur together with the Trip option.

07.11.5- Target Alarm Aux: (None, D.O.3, D.O.4, EB1: Aux1 to EB8: Aux8). Choose the desired option.

07.11.6- Target Trip Aux: (None, D.O.3, D.O.4, EB1: Aux1 to EB8: Aux8). Choose the desired option.

07.11.7- Air Alarm Aux: (None, D.O.3, D.O.4, EB1: Aux1 to EB8: Aux8). Choose the desired option.

07.11.8- Air Trip Aux: (None, D.O.3, D.O.4, EB1: Aux1 to EB8: Aux8). Choose the desired option.

07.12.1- Action: (None, Log, Alarm). Choose the desired option. Note that there is no Trip option.

07.12.2- Level High: Enter level in % of the end of the scale.

07.12.3- Aux Output: (None, D.O.3, D.O.4, EB1: Aux1 to EB8: Aux8). Choose the desired option.

M7.14-ANALOG 2 ALARM - ditto M7.12

M7.16-ANALOG 3 ALARM - ditto M7.12

M7.18-ANALOG 4 ALARM - ditto M7.12

PROGRAMMING

16k- MENU



M07.13-ANALOG 1 TRIP

This fault will occur if the fault is programmed to run in «Action» and the value of analog input 1 exceeds the programmed level.

07.13.1- Action: (None, Log, Alarm). Choose the desired option. Note that there is no Alarm option which will occur together with Trip.

07.13.2- Level High: Enter the level in % of the end of the scale.

07.13.3- Aux Output: (None, D.O.3, D.O.4, EB1: Aux1 to EB8: Aux8). Choose the desired option.

M7.15-ANALOG 2 TRIP - ditto M7.13

M7.17-ANALOG 3 TRIP - ditto M7.13

M7.19-ANALOG 4 TRIP - ditto M7.13



M07.20- EXTERNAL FAIL 1

This fault will occur if the fault is programmed to be executed in «Action» and the corresponding digital input becomes active.

07.20.1- Action: (None, Log, Alarm, Trip). Choose the desired option. Note that in the Alarm option, Trip will not be activated and in the Trip option, the Trip output will be activated, as well as the Alarm output if configured for this. If «Log» is chosen, only the fault will be logged on the Alarms and History screen, but the alarm or trip condition will not be triggered.

07.20.2- Trip Delay: Delay time that occurs after the digital input becomes active and the fault is detected.

07.20.3- Aux Output: (None, D.O.3, D.O.4, EB1: Aux1 to EB8: Aux8). Choose the desired option.

07.20.4- Assign Name: Enter the name of the Digital input with up to 5 characters to facilitate its identification in the system.

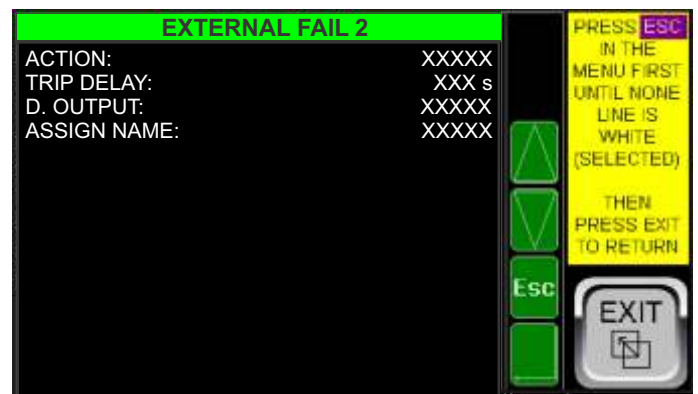

M07.21- EXTERNAL FAIL 2

This fault will occur if the fault is programmed to be executed in «Action» and the corresponding digital input becomes active.

07.21.1- Action: (None, Log, Alarm, Trip). Choose the desired option. Note that in the Alarm option, Trip will not be activated and in the Trip option, the Trip output will be activated, as well as the Alarm output if configured for this. If «Log» is chosen, only the fault will be logged on the «Alarms» and «History» screens, but the alarm or trip condition will not be triggered.

07.21.2- Trip Delay: Delay time that occurs after the digital input becomes active and the fault is detected.

07.21.3- Aux Output: (None, D.O.3, D.O.4, EB1: Aux1 to EB8: Aux8). Choose the desired option.

07.21.4- Assign Name: Enter the name of the Digital input with up to 5 characters to facilitate its identification in the system.

PROGRAMMING

16I- MENU



M08- TARGET ALARM LEVELS

In these Submenus you can enter each Alarm temperature level for the target or edit the levels that were automatically set by the Group Programming submenu.

M09- TARGET TRIP LEVELS

In these Submenus you can enter each Trip temperature level for the target or edit the levels that were automatically set by the Group Programming submenu.

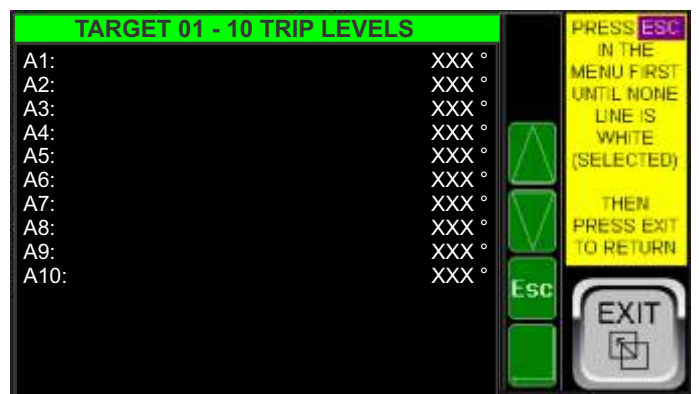
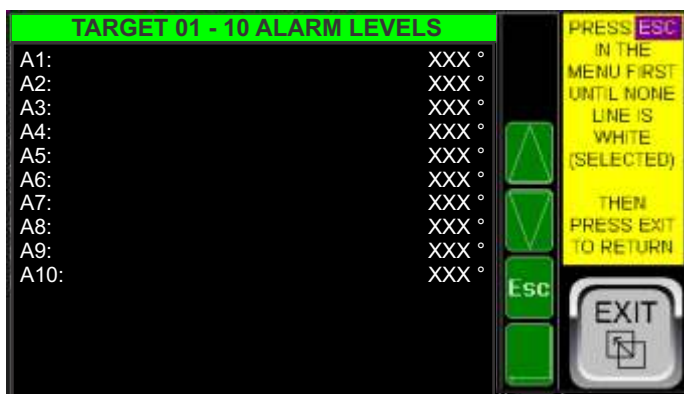

M08.1- TARGET 01 - 10 ALARM LEVELS

08.1.1- A1 to 08.1.10-A2 Enter or edit the level in Centigrade or Fahrenheit for the target alarm level.

M09.1- TARGET 01 - 10 TRIP LEVELS

09.1.1- A1 a 09.1.10-A2 Entre ou edite o nível em graus Centígrados ou Fahrenheit para o nível de alarme do alvo.

- M08.2- TARGET 11 - 20 ALARM LEVELS
- M08.3- TARGET 21 - 30 ALARM LEVELS
- M08.4- TARGET 31 - 40 ALARM LEVELS
- M08.5- TARGET 41 - 50 ALARM LEVELS
- M08.6- TARGET 51 - 60 ALARM LEVELS
- M08.7- TARGET 61 - 70 ALARM LEVELS
- M08.8- TARGET 71 - 80 ALARM LEVELS
- M08.9- TARGET 81 - 90 ALARM LEVELS
- M08.10- TARGET 91 - 100 ALARM LEVELS
- M08.11- TARGET 101 - 110 ALARM LEVELS
- M08.12- TARGET 111 - 120 ALARM LEVELS
- M08.13- TARGET 121 - 125 ALARM LEVELS

Same as M8.1 above

- M09.2- TARGET 11 - 20 TRIP LEVELS
- M09.3- TARGET 21 - 30 TRIP LEVELS
- M09.4- TARGET 31 - 40 TRIP LEVELS
- M09.5- TARGET 41 - 50 TRIP LEVELS
- M09.6- TARGET 51 - 20 TRIP LEVELS
- M09.7- TARGET 61 - 70 TRIP LEVELS
- M09.8- TARGET 71 - 80 TRIP LEVELS
- M09.9- TARGET 81 - 90 TRIP LEVELS
- M09.10- TARGET 91 - 100 TRIP LEVELS
- M09.11- TARGET 101 - 100 TRIP LEVELS
- M09.12- TARGET 111 - 120 TRIP LEVELS
- M09.13- TARGET 121 - 125 TRIP LEVELS

Same as M9.1 above

PROGRAMMING

16n- MENU



M12- BACKUP / RESTORE DATA

M12.1- Enable Auto-run: Auto Run must be enabled as well as Auto Load if it is desirable to have the Fail-Safe system operational. After Auto Load is executed, if the relay detects that the program is missing or corrupted.

M12.2- Enable Auto-Load: It must be enabled in the same way as described above.

M12.3- Flash Backup: This sub-menu takes you to the screen below where you can clear the backup performed previously or perform a first or new backup of the entire RAM memory to the internal Flash memory. This internal backup is not used in case of a Fail-Safe action with Auto Load and Auto Run.

Only execute the Make Backup command after having all the parameters programmed and making sure that the relay is operating correctly and without active or non-cleared faults on the alarm screen.

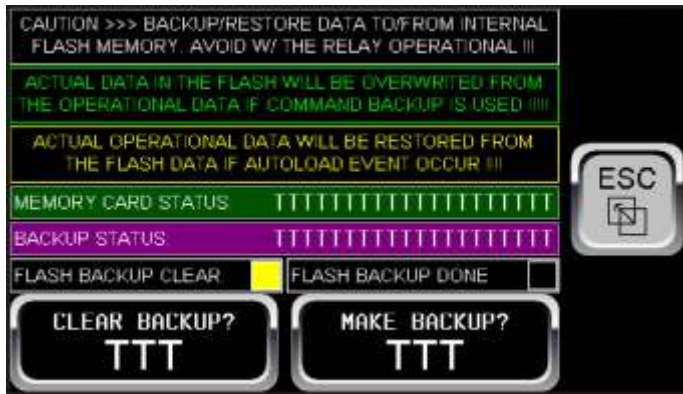

In addition to the «Clear Backup» and «Make Backup» buttons and the «Cleared» or «Done» indications, there is a memory card status field, as previously described, and a Backup Status field, with the messages previously described on Screen MS10, which can be: 1- STANDBY / 2- OK - PROCEED / 3- ERROR - CHECK CARD / 4- DONT BACKUP ON FAIL / 5- OK - DONE / 6- WRITING / 7- READING / 8-BUSY.

Note that the Clear Backup and / Make Backup command buttons are invisible if the conditions for these commands are not currently suitable.

M12.2- CLONE PARAMETERS

This sub-menu takes you to the Clone Parameters screen below.

ATTENTION: This action, if commanded «Restore», will overwrite all the programming parameters with those contained in the memory card, in the specific file.

To use this function, a previously formatted memory card, with a maximum of 32 Gb, must be inserted in the upper slot of the relay. You can command «Backup» to save a new file with the data or «Restore» to restore them.

In this way, if several Zyggot V5F Relays are used with the same programming, it is enough to program one of them and clone the data in the other relays.

In this action, the programming password is not saved or restored, which in fact is one of the parameters.

On the screen below you can see that there are two fields, one with the card status messages as described in the explanation of the Info 4 screen and the other with the Backup status messages as described previously in Screen MS10, which are: 1- STANDBY / 2- OK - PROCEED / 3- ERROR - CHECK CARD / 4- DONT BACKUP ON FAIL / 5- OK - DONE / 6- WRITING / 7- READING / 8-BUSY.

Note that the Backup and Restore command buttons are invisible if the conditions for these commands are not currently suitable.

Note: Unlike the Flash Backup command, which copies all the Ram memory to a non-volatile internal memory, the Clone Parameters command described here only saves the values of the parameters entered in the programming menu and serves as documentation to be saved, such as possible parameter restoration to a previous condition when changes are made to the programming or, as already mentioned, to clone the same parameters in other relays of the same plant, for example.

To clone the parameters to other relays, copy the «Datacard» file from the memory card of the relay that generated the file to be cloned to the other relay cards and then execute the Restore command on each one of them.

Attention: Be careful in this case not to execute the Backup command on the other relays, before executing the Restore command.



PROGRAMMING

16o- MENU

M13-ETHERNET

The ZYGGOT V5F Relay has ETHERNET communication and can be accessed from anywhere on the planet. Several communication protocols are incorporated, the user just need to define the communication parameters in the following programming screens and use it.

You can, for example, obtain all temperature readings and flag states from a computer or mobile device or even interface with a DCS system anywhere as long as you have access to Ethernet and the relay is connected to a local network LAN with access to the external WAN network and the addresses programmed in the relay are known.

You can eventually configure the relay remotely if necessary, such as alarm and trip levels, etc.

It is also possible for the manufacturer to perform an eventual firmware update remotely, if necessary.

The available protocols are:

- ICMP** - Internet Control Message Protocol.
- SRTP** - Service Request Transport Protocol.
- TCP/IP** - Transmission Control Protocol (Modbus TCP Server or Modbus Slave).
- ETHERNET/IP** - Internet Protocol (Ethernet IP Server).
- FTP** - File Transfer Protocol
- HTTP** - Hypertext Transfer Protocol..
- ASCII Over TCP/IP** - ASCII Transmission Control Protocol.
- NTP** - Network Time Protocol.

It is not the intention of this manual to go into each of the protocols in depth. It is up to the user to know the protocol he intends to use.

The following is a brief description of each Protocol and their limitations in this application.

ICMP - Internet Control Message Protocol. Internet Control Messaging Protocol), is an integral protocol of the IP Protocol, defined by RFC 792, is used to communicate network layer information, being the most common use to provide error reports to the original source. Any computer using IP must accept ICMP messages.

Although several tools are possible in this protocol, in the Zyggot V5F relay only the Ping function is implemented, which can be used to check if a device is responding to commands, that is, it is accessible on the network.

SRTP - Service Request Transport Protocol. Service Request Transfer Protocol (SRTP) is a GE Fanuc Automation protocol, which allows a remote SRTP client to request services from an SRTP server. In this case, the ZYGGOT V5F relay, which acts as an SRTP server, responds to requests from one or more SRTP Clients.

As SRTP was originally designed to support the services provided by the GE Fanuc Series 90, the ZYGGOT V5F SRTP protocol does not support all possible SRTP

services. The implementation of SRTP by the ZYGGOT V5F Relay is mainly limited to the services required for the exchange of log data.

Settings:

Port Used: 18245 TCP

Maximum number of Connections: 16

The following SRTP service requests are supported by the ZYGGOT Relay V5F.

- 0 PLC_SSTAT**
- 1 PLC_LSTAT**
- 4 READ_SMEM**
- 7 WRITE_SMEM**
- 33 CHG_PRIV_LEVEL**
- 67 RET_CONFIG_INFO**
- 79 SESSION_CONTROL**
- 97 PLC_FEATURES_SUPP**

Register Types:

- 8 %R 16 bit**
- 10 %AI 16 bit**
- 12 %AQ 16 bit**
- 16 %I 8 bit**
- 18 %Q 8 bit**
- 20 %T 8 bit**
- 22 %M 8 bit**
- 30 %S 8 bit**
- 70 %I 1 bit**
- 72 %Q 1 bit**
- 74 %T 1 bit**
- 76 %M 1 bit**
- 84 %S 1 bit**

TCP/IP - Transmission Control Protocol (Modbus TCP Server). The TCP/IP protocol is an acronym for Transmission Control Protocol, used for sending and receiving data on the web.

The TCP/IP protocol is the language of computers and specifies the way data is exchanged over the internet.

Most computers talk over TCP/IP, providing end-to-end communications.

Highly scalable and widely used, this protocol requires little central management and is designed to make networks reliable, with the ability to automatically recover in the event of any device failure.

Each device has an IP address that identifies it, allowing it to communicate and exchange data with other connected devices.

Settings:

Port Used: 502 TCP

Maximum number of Connections: 16

Note: Modbus must be enabled on the Zyggot V5F relay.

IP - Internet Protocol (Ethernet IP Server). The IP protocol is the network layer communication protocol in the Internet protocol suite for relaying datagrams across network boundaries. Its routing function allows for the interconnection of networks and essentially establishes the

PROGRAMMING

16o- MENU

Internet.

IP is tasked with delivering packets from the source host to the destination host just based on the IP addresses in the packet headers. For this, IP defines packet structures that encapsulate the data to be delivered. It also defines addressing methods that are used to label the datagram with source and destination information.

Settings:

Ports Used: 44818 TCP or 2222 UDP

Maximum number of Connections: 2

Start Send (Produced) Register = R2001 /// Words Count = 248

Start Received (Consumed) Register = R2501 /// Words Count = 199 /// Status Register = R5513

FTP - File Transfer Protocol is the protocol that allows transmission of files over the network. Through it, it is possible to read and access the files of the memory card inserted in the respective slot of the relay and where the temperature readings, etc. are recorded. It is a hardware-independent standard/generic protocol over a way of transferring files and is also a transfer program.

Transferring data over computer networks typically involves transferring files and accessing remote file systems (with the same interface used for local files). FTP is based on TCP, but predates the TCP/IP protocol stack, and later adapted to it. It is the standard for transferring files.

Settings:

Ports Used: 20 and 21 TCP

Maximum number of Connections: 4

User Name 1 (Read Only) = Z_FTP_USER /// Password = 899468

/// User Name 2 (Read / Write) = Z_FTP_VRX

/// Password = xxxx

HTTP - Hypertext Transfer Protocol.

The Hypertext Transfer Protocol is a communication protocol (in the application layer according to the OSI Model) used for distributed and collaborative hypermedia information systems. It is the basis for World Wide Web data communication.

Hypertext is structured text that uses logical links (hyperlinks) between nodes containing text. HTTP is the protocol for exchanging or transferring hypertext.

Settings:

Port Used: 80 TCP

Maximum number of Connections: 1

User Name: = ZYGGOT_WS

Password: 9387

ASCII Over TCP/IP - ASCII Transmission Control Protocol.

The ASCII Transmission Control Protocol, or ASCII TCP is a reply/query/question and answer communication protocol in which a host PC uses ASCII characters to send commands to a device and receive responses from the device.

This protocol is designed to send and receive ASCII data over the Ethernet port of the Zyggot Relay. The Relay acts as a server when using this protocol.

Settings:

Port Used: Entered in the Configuration.

Tx Trigger: %M100 (transmits 500 Bytes when set = 1

Tx Bytes (8bits): 500 Bytes (250 Words) in the sequence Bytes 1 and 2 form Word 1 containing the temperature of Target 1, Bytes 2 and 3 containing the temperature of Target 2 and so on until completing 125 sensors, when if Air temperatures of sensor 1, Sensor 2 etc. until completing 125 sensors, therefore, totaling 500 Bytes (250 Words).

Rx Copy Trigger: %M99 (copies 504 Bytes (252 Words) when set = 1 for alarm and Trip parameters. Before being set, the user must transmit all Bytes already configured as half Word each, referring to the integer value alarm levels for each sensor.

Rx Bytes (8 Bits): 504 Bytes (252 Words): the first 500 Bytes must form 250 Words referring to the target alarm levels for 125 sensors, then Trip levels for 125 sensors and the last 4 Bytes must form the 2 words regarding alarm and trip levels for all sensors (always the same for all).

Maximum number of Connections: 1

NTP - Network Time Protocol. NTP is a protocol for synchronization of equipment clocks based on the UDP protocol over port 123. It is used for clock synchronization of a set of equipment and devices in data networks with variable latency. NTP makes it possible to keep a device's clock synchronized with the time always right and with great accuracy.

Configuration: Five NTP server addresses in Brazil are pre-defined. Under Consultation we can define any other world server.

The factory default Servers are as follows.

a.st1.ntp.br

b.st1.ntp.br

c.st1.ntp.br

d.st1.ntp.br

gps.st1.ntp.br

PROGRAMMING

16o- MENU

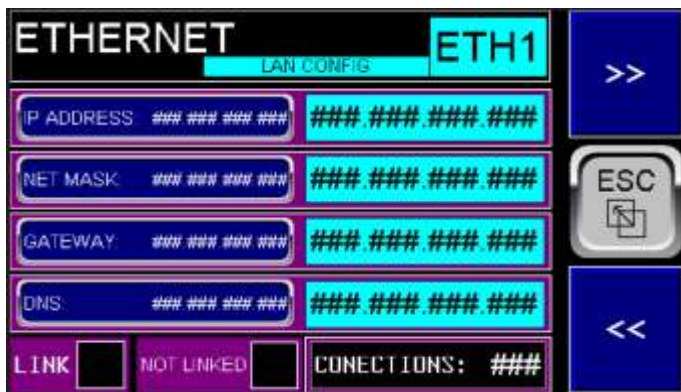

M13A- ETHERNET - LAN CONFIG

M13A.1- IP ADDRESS: Enter the address of what the Zyggot V5F relay will have on the LAN network.

M13A.2- NET Mask: Enter the number referring to the network mask. Typically 255,255,255.0

M13A.3- Gateway: Enter the number referring to the Gateway if necessary. If not needed, leave it at 0.0.0.0

M13A.4- DNS: Enter the Domain Name Server address if necessary. If not used leave 0.0.0.0

This screen also shows whether the Ethernet cable is connected or not and the number of connections. Note: the number of connections may eventually show «zero» even when connected if the transmissions are not repetitive and because it is very fast there is not enough time to show it on the screen.

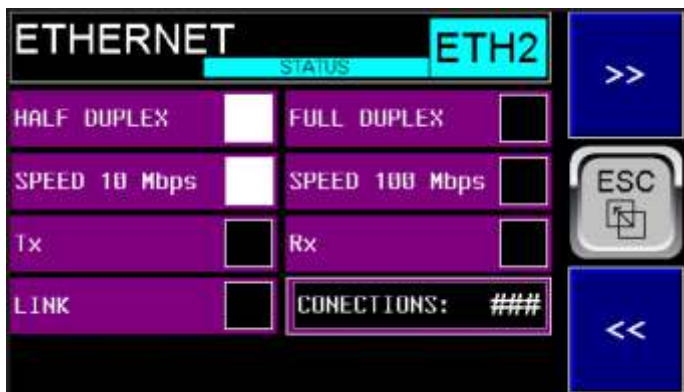

M13B- ETHERNET - STATUS

This screen only shows the different statuses of the connection, not having any field to be inserted. The Statuses Shown are:

M13B.1- HALF DUPLEX or FULL DUPLEX: Shows Connection Mode.

M13B.2- SPEED 10 Mbps or 100 Mbps: Shows the connection speed

M13B.3- Tx and Rx: Shows whether it is transmitting or receiving data.

M13B.4- LINK: Ethernet cable is connected (Linked) or not and the number of connections. **Note:** the number of connections may eventually show «zero» but be connected if the transmissions are not repetitive and because it is very fast there is not enough time to show it on the screen.



M13C- ETHERNET - ICMP (PING)

This screen, in the same way as the corresponding screen in the Report Menu, allows you to test if a certain device on the network is responding, that is, if it is active on the network.

M13C.1- PING ADDRESS: Enter the address to ping.

M13C.2- PING RESPOND TIME: Shows the time in milliseconds that the equipment took to respond.

M13C.3- Tx and Rx: Shows whether it is transmitting or receiving data.

M13C.4- PING TIMEOUT: If the equipment does not respond in less than 1 second, it will indicate Timeout, that is, it is not responding.

M13C.5- STAR and STOP: Starts and stops PING. When exiting the screen, a Stop is automatically given.



M13D- ETHERNET - TCP/IP PROTOCOL - MODBUS SLAVE

This screen refers to the main protocol of the Zyggot V5F relay which allows to operate fully Modbus, with all functionalities and valid addresses besides offsets etc.

The SUPERGER program provided free of charge by Varixx allows, among other features, to completely test the Modbus Over Ethernet connection with a computer connected to the Zyggot V5F relay.

PROGRAMMING

16o- MENU

M13D.1- MODE: Informational field only. Shows the mode (Always TCP).

M13D.2- ENG: Information only field. Show port (Always 502)

M13D.3- ENABLE WRITE INHIBITION: Select YES to inhibit any possibility of writing to internal parameters of the Zyggot relay, thus increasing safety. Readings of any registers or parameters, Temperatures, Flags, etc remain functional if write inhibit is selected as Yes. **Note:** Always prefer to program the parameters directly in the relay or through the memory card, as described in this manual, for safety.

M15E.6- PROGRAM PERMISSION: Can be set to "Enabled" or "Disabled" to allow or not the programming of the relay parameters via Ethernet IP. Not enabled in this version, so it is always set to "Disabled"

M15E.7- CONNECTED: Indicates that the Ethernet connection is OK.

M15E.8 - DATA VALID (in the Consumed section): For informational purposes only on this screen. The corresponding word in the Ethernet IP server table (%R3328) must be set to value 1, that is, its bit 1 set when the data is valid to be written to the relay after a new writing page is selected. (Note not enabled in this version. Only page 0 will be effective - see table).

M15E.9 and M15E10 - CONNECT CLASS 3 and CONNECT CLASS 1: For informational purposes only.

IMPORTANT NOTE: always prefer to program the parameters directly on the relay or via the memory card, as described in this manual, for safety reasons.

Note that with a single parameter programming on a relay, the identical programming can be replicated on other relays via the memory card.

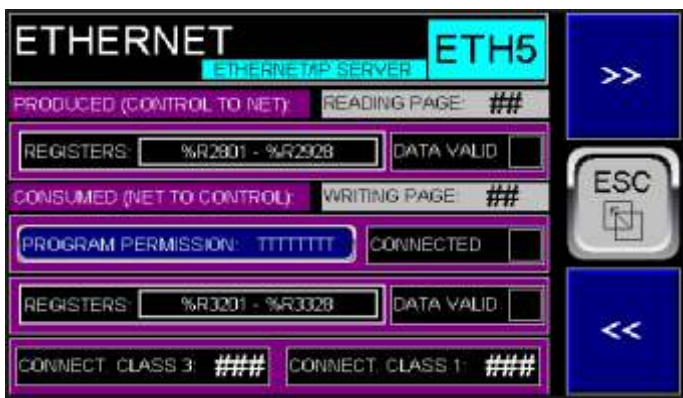

M15E- ETHERNET IP PROTOCOL

This screen refers to the Ethernet IP protocol. Unlike the TCP/IP (Modbus Over Ethernet) protocol described above, the data read and written will be transferred all at once, respecting the maximum number of words, as described below.

M15E.1- READING PAGE: From 0 to 16 for reading up to 128 words per page. Corresponds to record %R2927 in the Ethernet IP Server table.

M15E.2- REGISTERS (PRODUCED): For informational purposes only. Always %R2801 to %R2928: will contain the various words with data according to the ETHERNET IP Server table later in this manual.

M15E.3- DATA VALID (in the PRODUCED section): For informational purposes only. For informational purposes only on this screen. The corresponding word in the Ethernet IP Server table (%R2928) will have the value 1, that is, its bit 1 will be set when the data is valid after the page to be read has been changed. If there is no page change, this bit will remain set indefinitely and, if there is a page change, it will briefly go to zero and then to 1 again when the data read is changed.

M15E.4- WRITING PAGE: From 0 to 16 to write up to 128 words on each page. Corresponds to register %R3226 in the Ethernet IP Server table. (Note: Not enabled in this version. Only page 0 will be effective - see table).

M15E.5- REGISTERS (CONSUMED): For informational purposes only. Always %R3201 to %R3328: will contain the various words to be written to the relay with data according to the ETHERNET IP SERVER table later in this manual. (Note: Not enabled in this version. Only page 0 will be effective - see table).

PROGRAMMING

16o- MENU

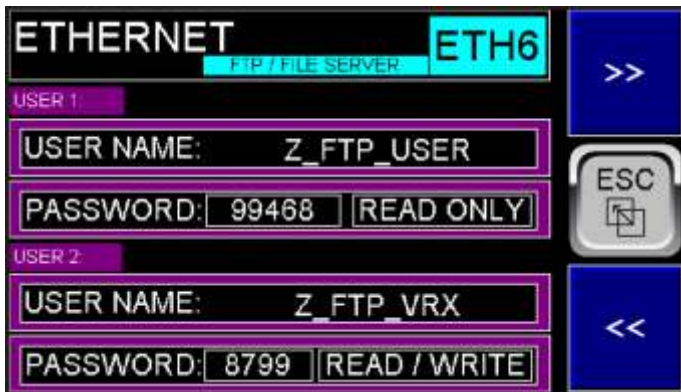

M13F- ETHERNET - FTP PROTOCOL - FILE TRANSFER PROTOCOL

This screen refers to the protocol that allows readings and copies of files stored on the memory card of the ZYGGOT relay, allowing to obtain data from historical records of temperature readings, for example. To access any file on the card, you must know the name of the file as recorded on the card. You must use the name of the file and its full path (with directories and sub directories, if any), as in the examples below.

Assuming that the relay IP is 192.168.1.10 and you want to read the log.txt file which is in the root of the card directory Then write in the search field:

192.168.1.10/log.txt and press Enter.

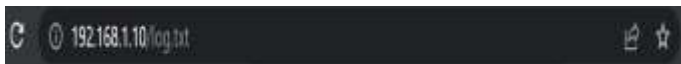

A screen will appear asking for Login and Password. Once you have entered the correct login and password data, the file will be read and can be saved on your computer.

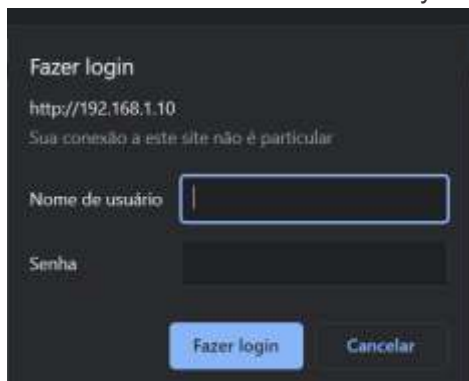

M13F.1- USER 1 - USER NAME: Informational only. Always Z_FTP_USER.

M13F.2- PASSWORD: Information only. Always 99468

M13F.3- READ ONLY. Informational only.

M13F.4- USER 2 - USER NAME: Informational only. Always Z_FTP_VRX

M13F.5- PASSWORD: Informational only. Always 8799.



M13G- ETHERNET - HTTP PROTOCOL - WEB SERVER

This screen refers to the HTTP or HTTPS protocol that allows communication with Browsers using Hypertext Transfer Protocol.

M13G.1- USER NAME: Informational only. Always ZYGGOT_WS.

M13G.2- PASSWORD: Informational only. Always 9387



M13H- ETHERNET IP

This screen refers to the ASCII OVER TCP/IP protocol.

M13H.1- BY NUMBER: Enter the desired port.

M13H.2- Tx BYTES: Informational only. Always 500 (250 Words).

M13H.3- Tx TRIGGER (%M100): When this flag is set to one, 500 Bytes will be transmitted in ASCII format, which must be combined (transformed into 250 Words of 16 bits which will contain the target and air temperatures of up to 125 sensors.

M13H.4- Rx BYTES: Informational only. Always 506 (253 Words).

M13H.5- COPY ENABLED: Indicates whether copying buffer records to real records is currently enabled. To indicate «enabled» it must be with «Status Received» OK and not show «Rx Overflow» or «Socket» errors.

PROGRAMMING

16o- MENU

M13H.6- STATUS RECEIVED: Indicates that a successful reception of 504 Bytes (252 Words) has occurred.

After writing the data to be programmed, according to the table at the end of this manual, when the Flag corresponding to «Copy Trigger» is set, the data is copied to the corresponding parameters of the Zyggot V5L relay.

These data will be transferred to the parameters according to the table at the end of this manual.

M13H.6- COPY TRIGGER: In this field, choose the method to execute the Copy of data from the Buffer region to the real parameter records. You can choose two options namely: «%M99» or «BYTE T».

If %M99 is selected, at the end of the data transmission to the relay, the %M99 Flag must be set to validate the data, when the relay will copy the data to the real parameter registers and reset the %M99 flag. To set the %M99 flag you must use the normal TCP/IP protocol.

If BYTE T (Byte Termination) is selected, the last bit of the second transmitted word (composed of Bytes 3 and 4) must be set. The first word (Bytes 1 and 2) must contain the number of bytes to be transmitted to the relay (always 506).

After writing the data to be programmed, starting from Byte 5 and 6, according to the table at the end of this manual, when setting the «Copy Trigger» Flag (%M99 or BYTE T) the data is copied from the internal buffer region to the parameters of the Zyggot V5L relay.

M13H.7- STATUS Rx OVERFLOW: Indicates Overflow error on reception.

M13H.8- STATUS Tx OVERFLOW: Indicates Overflow error in transmission.

M13H.9- SOCKET STATUS: Indicates Socket error.

IMPORTANT NOTE: always prefer to program the parameters directly in the relay or through the memory card, as described in this manual, for safety. This protocol is accessible primarily through the ability to read up to 250 target and air temperature readings. The part referring to writing data is operational but must be avoided, due to the possibility of programming errors and the possibility of even overwriting important data and leaving the relay inoperative, requiring factory maintenance. So either don't use the programming function by this method or use it with extreme caution.

It is more practical and simple to obtain temperature data, etc. using the TCP/IP Protocol, described above, where all Modbus over Ethernet communication can be implemented and all data internal to the Zyggot V5L Relay can be obtained, in addition to writing all the parameters. However, there is the possibility of using the ASCII Over TCP/IP protocol to obtain the temperature data from the sensors, but the user will have the obligation to convert each 2 ASCII

Bytes into an Integer word, in order to obtain the numerical values referring to the temperatures of according to the corresponding table at the end of this manual. In the same way, all alarm and trip levels of each sensor can be transferred at once up to 125 sensors and two more alarm and trip levels for air temperatures, but in the same way the user should be responsible for transforming the data of Integer words in 2 bytes in ASCII. However, we do not recommend this method due to the risk of erroneous programming and obtaining erroneous data.

Note that with a single programming of parameters in one relay it is possible to replicate the identical programming in other relays through the memory card.



M13I- ETHERNET NTP PROTOCOL

This Screen refers to the Ethernet Network Time Protocol, through which devices can obtain exact time data from previously established servers.

M13I.1 to M13I.7- List of pre-established servers.

TESTING THE ETHERNET CONNECTION

USING A WINDOWS COMPUTER

A simplified way to test the ETHERNET connection is described below, using a simple executable software provided by Varixx (or using the Superger software (see end of this manual), also provided free of charge by Varixx or any similar program available on the world wide web). Let's consider here the explanation using the **pyModbusTCPV5** executable

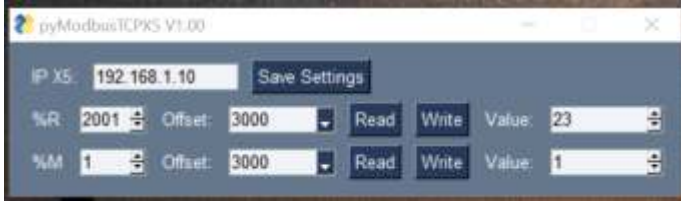

1- Initially connect the appropriate RJ45 cable between the computer and the LAN port of the Zyggot V5F relay and open the Windows Settings and select the Network and Internet option, which will open the properties screen that will contain content as below, among others.



2- Click on the option «Change adapter options». The following screen will open, in which an unidentified Ethernet connection should appear, in addition to the other existing connections.



3- Right-click the unidentified Ethernet connection. The following screen will open.

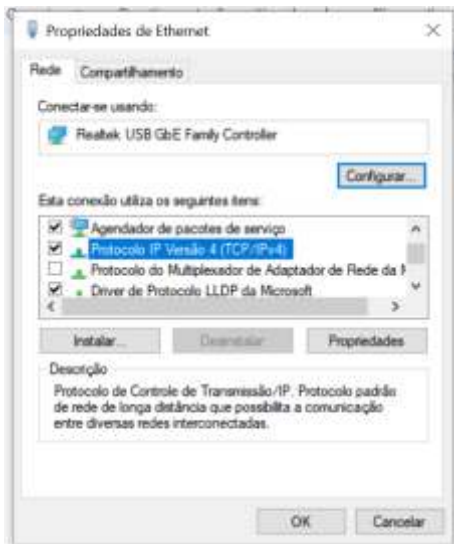

4- Double-click on the IP Protocol Version 4 (TCP/IPv4) option. The following screen will open.



4- Enter an IP address that is different from your local network, for example if your network is **192.168.0.1** and press OK. You must use a network that has the third digit different from it. For example, we use **192.168.1.11** and in the **pyModbusTCPV5** program we use **192.168.1.10** so the computer's address on the network will be terminated with 11 and the Zyggot V5F relay will have a termination with 10. At this point the two devices should already be connected and exchanging data. On the Zyggot relay, on the Menu screen, choose the option **16. REPORT** and then the option **ETHERNET REPORT / STATUS**. Then go to the ER3 screen and activate the START option to test the connection with PING.



If the connection is OK, it will indicate a response time in the **PING RESPONSE TIME** field which should be around 0.01 ms. If the connection is not OK, it will indicate **PING TIMEOUT** and the PING RESPONSE TIME field will be all **++++++**.

If the connection is OK, open the executable program **pyModbusTCPV5** and put the chosen address, in this example 192.168.1.10 and click on Save Settings. Choose a register to be read, for example %R2001, which will contain the target temperature of Sensor 1, plus the required offset according to the Modbus tables in this manual and click **Read**. The current temperature should appear in the Value field. In the same way, flags of type %M can be read.

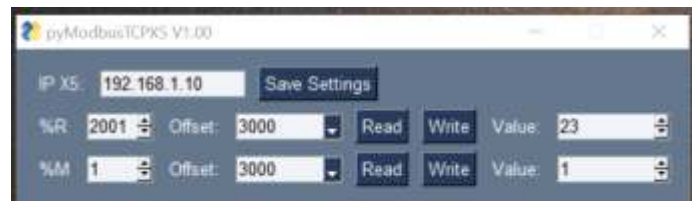

Attention: You can write to registers as well, but avoid this if you don't know that a certain register can be overwritten, as it may change Zyggot relay configuration parameters.

OPERATION

IDENTIFICATION SCREEN

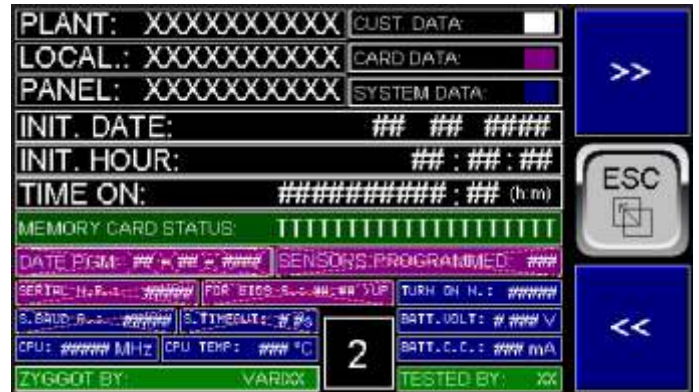

When energized, the relay will show the above identification screen and then perform a self-test, whose result can be seen in the reports in the «System Data» item.

Then, if the **Start of Operation** has already been commanded (See next page) the relay shows the initial screen below, the first of 3 that can be paged through the >> and << keys. These same screens can be accessed at any time from the Main Menu, using the «Esc» key.

INFORMATION SCREENS



The first information screen above shows the system identification, embedded software version, date and time of the internal real-time clock, communication status with the **S. Comm OK** or **S. Comm Error** sensors and some indications at the bottom that are repeated on several screens to facilitate the overview of the Alarm and Trip system, namely: **FAIL**, which will be filled in red if there is an active fault, **TRGT** which will be filled in white if there is a fault related to the target temperature, **AIR**, which will be filled in white if there is a fault related to air temperature (sensor body), **NR** sensor not responding, **ALRM** which will be filled in yellow if there is an active alarm output and **TRIP** which will be filled in red if there is an active Trip output.

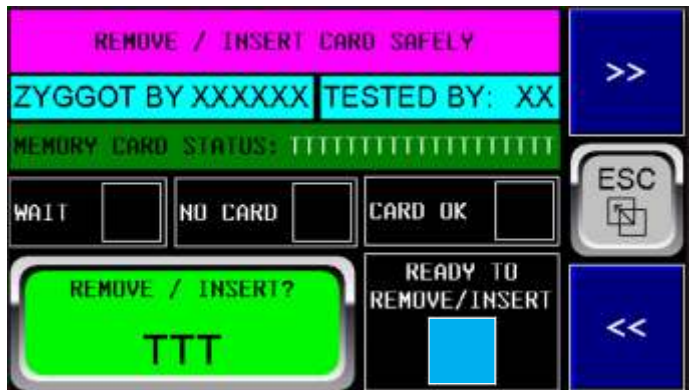

INFO screens 1 to 5 show system data and secure memory card insertion and removal commands, already described in the Main Screens section above.

OPERATION

Normal Operation:

Operation is fully intuitive and easily learned in minutes.

It is understood that the sensors are already fully addressed by the PC program and correctly networked as described elsewhere in this manual.

1- When the system is powered up, at startup, the operation start confirmation screen will appear only once, where the user confirms this in the **Proceed** button, with the option «Yes» and the timer on (Time ON) starts.



2- After the procedure in item 1 or when the system is powered up, the main screen 1 (MS1) will appear a second time and by means of the >> and << keys, it is possible to navigate through the 11 main screens (MS1 to MS11), as already described. Pressing «ESC» goes to the Main menu (below).

Before operating, activate the system, have the values and parameter options that you want to enter in the Programming menu at hand and carry out all the programming of it, without definitively connecting the Alarm, Trip or Auxiliary outputs to avoid an inadvertent trip in the system.

The first thing to do in the first operation is to check that all sensors are flashing correctly and responding. You can also command the «Flash» of all at the same or one at a time to check addresses and if they are active on the network. This is done via the Main Menu Flash key below.



3- Through this menu, it is possible to access all the screens of the system in addition to the Programming Menu.

By pressing «ESC» on this screen, the first System Info screen appears (below) and you can navigate through the 5 screens with the keys >> and <<.



4- Use the corresponding keys to access all Sub-screens for each feature and interact or enter values on each screen if necessary, as described in the Main Screens for Operation section above.

5- Note that the «Alarm» key may or may not have a flashing red outline. If there is, one should press it and enter the ALARM screen to recognize and eventually clear fault indications.

6- Note that the relay can optionally be connected to the user's DCS system via a Modbus port as described. However, this connection is not necessary for the system to be fully protected.

SCREEN FLOW

INFO SCREENS

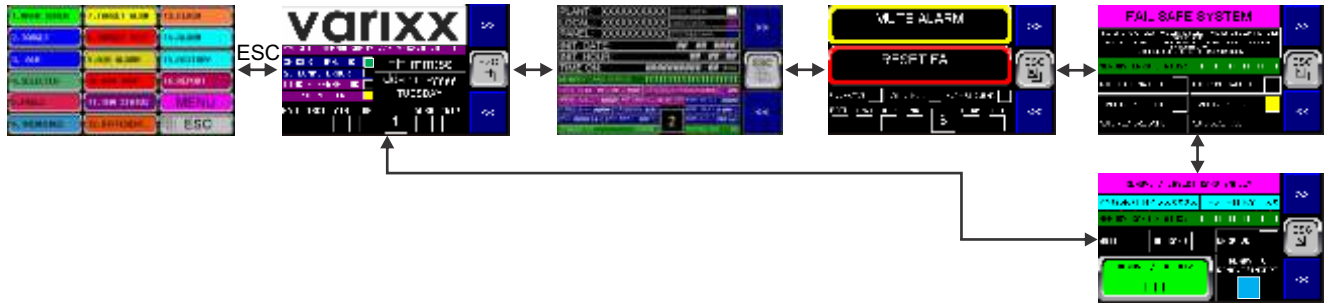

MENU - ENTER

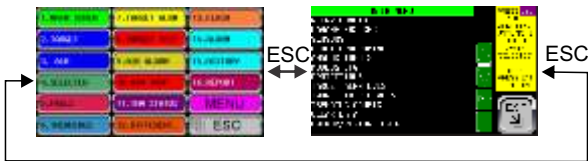

1. MAIN SCREEN

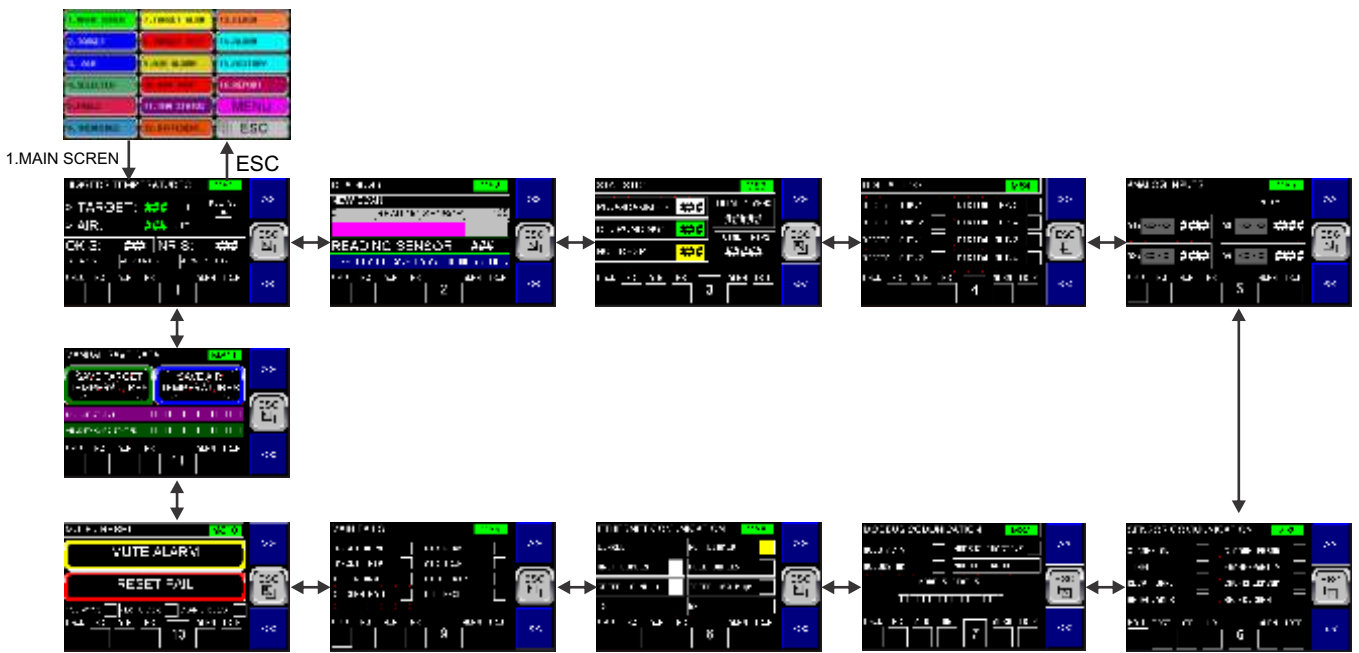

2. TARGET

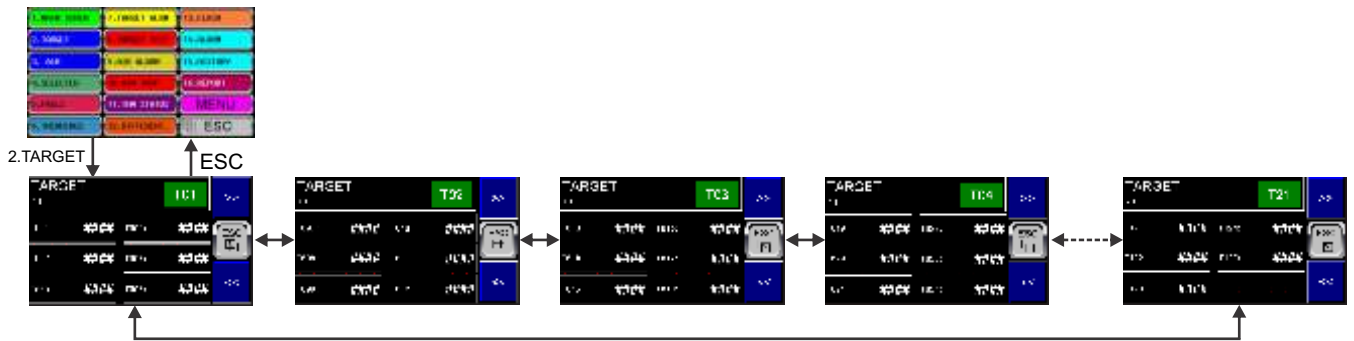

SCREEN FLOW

3. AIR



4. SELECTED

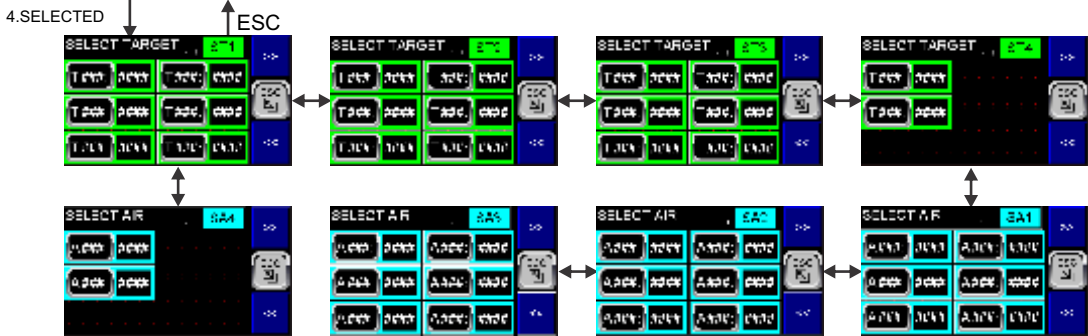

5. FAILS

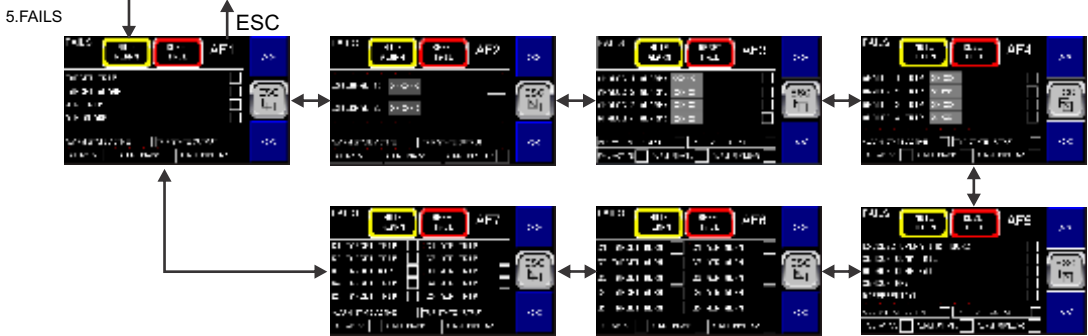

SCREEN FLOW

6. TRENDS

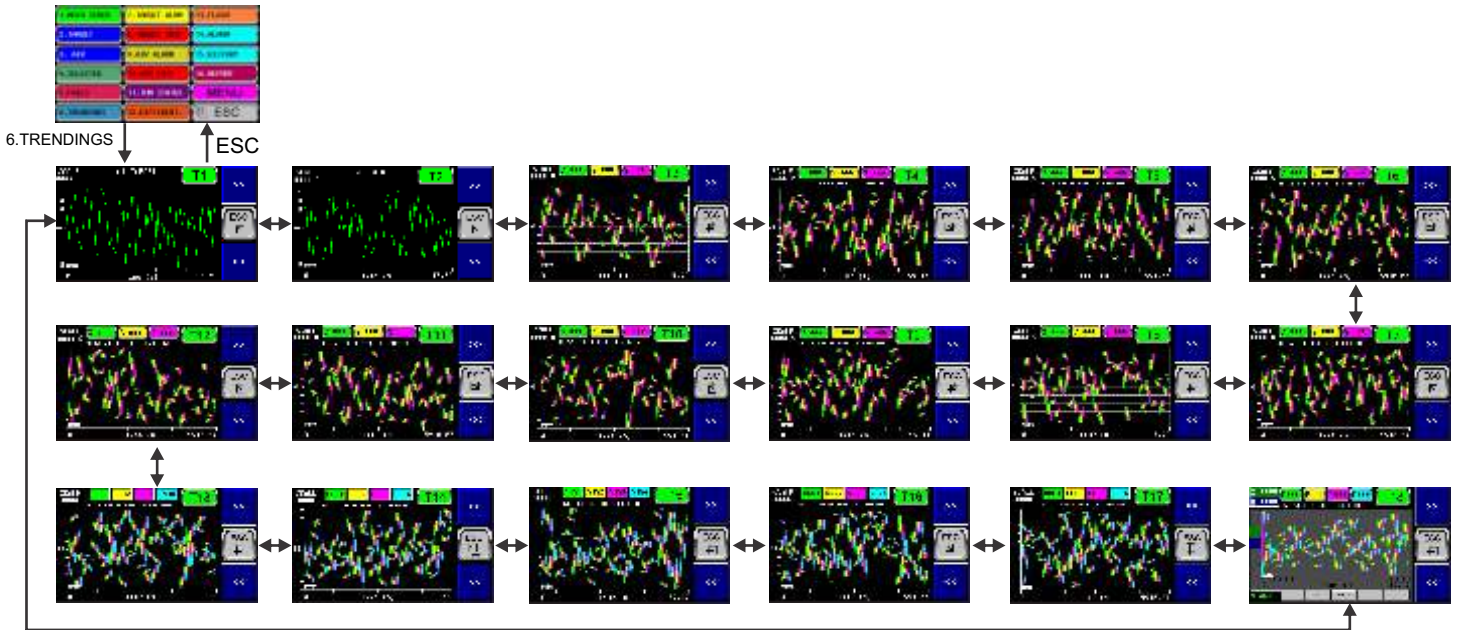

7. TARGET ALARMS

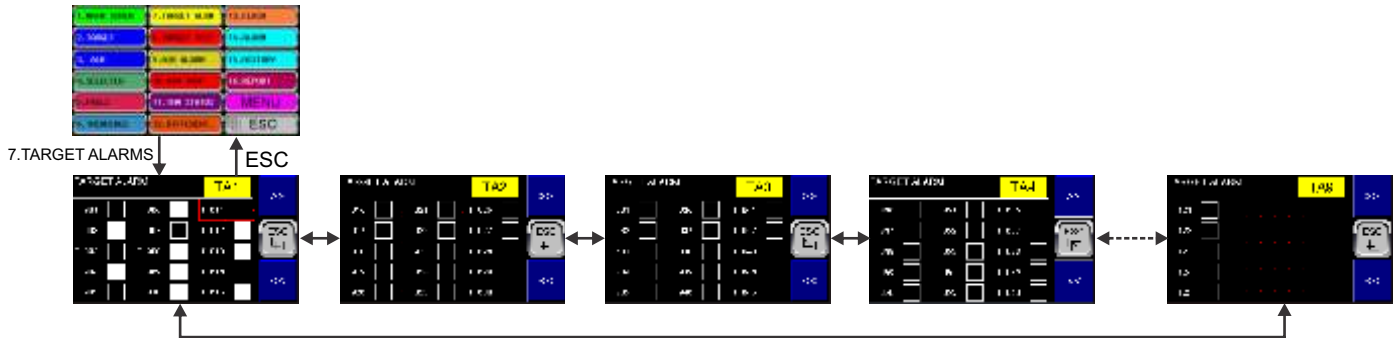

8. TARGET TRIPS

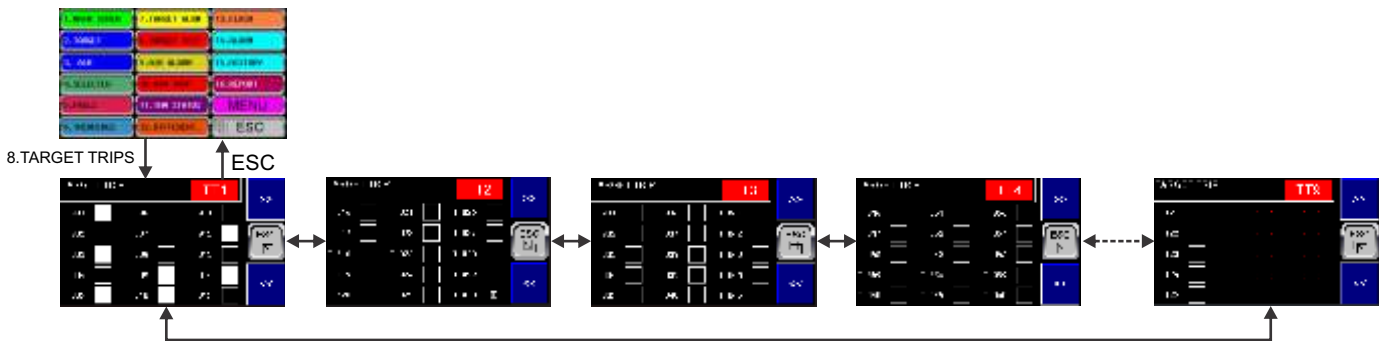

SCREEN FLOW

9. AIR ALARMS

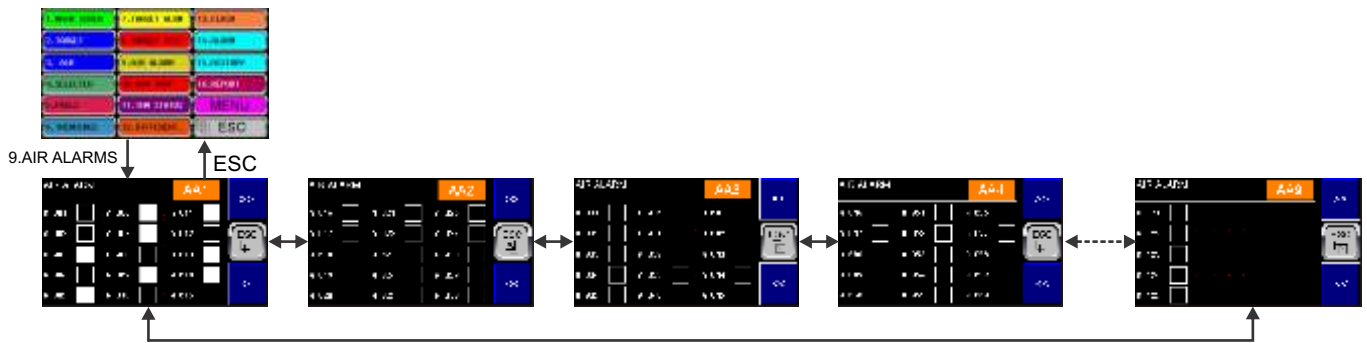

10. AIR TRIPS

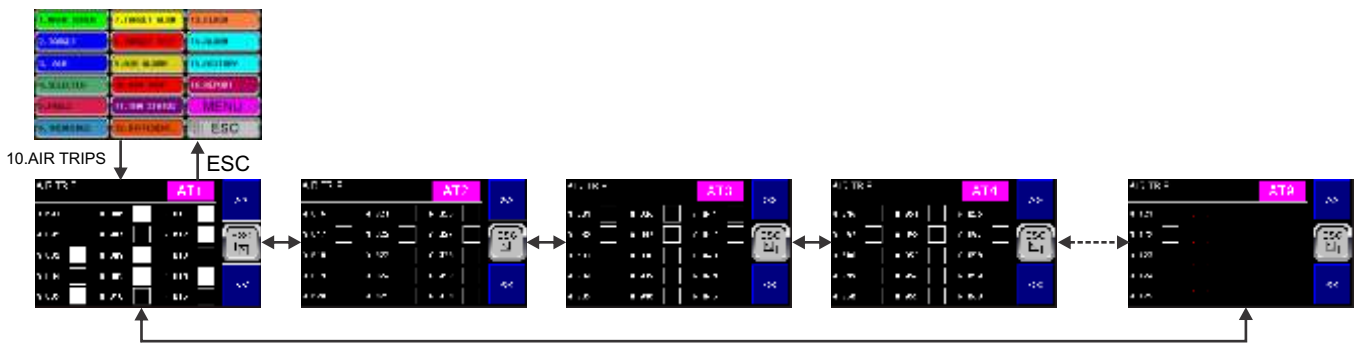

11a. NOT RESPONDING

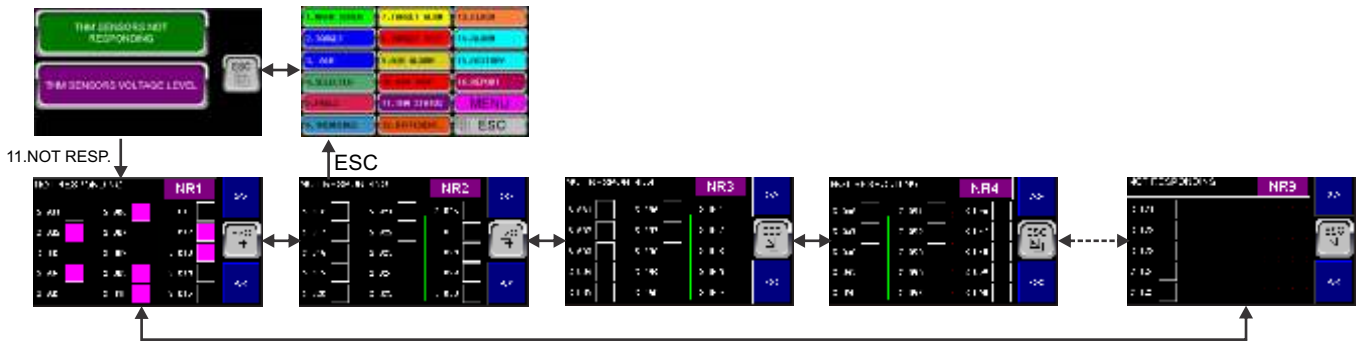

11b. THM SENSORS VOLTAGE LEVEL



SCREEN FLOW

12. DIFFERENTIAL

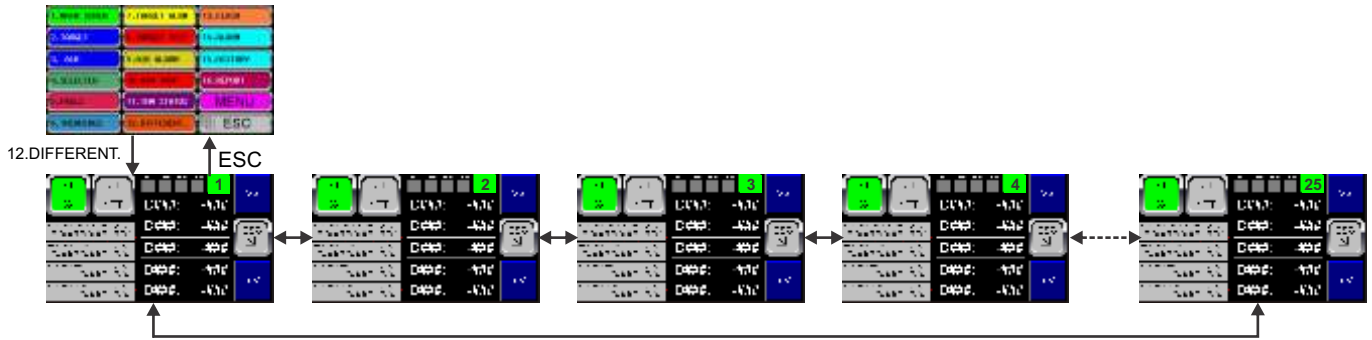

13. FLASH

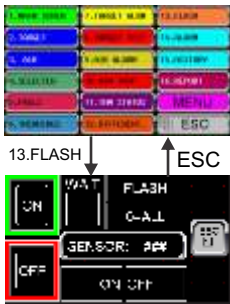

14. ALARM



15. HISTORY

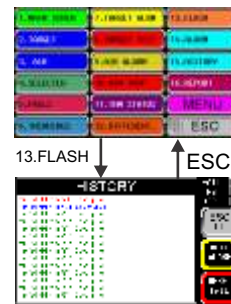

1/2 PROGRAM REPORT



ETHERNET REPORT / STATUS
(see other page)

PROGRAM REPORT

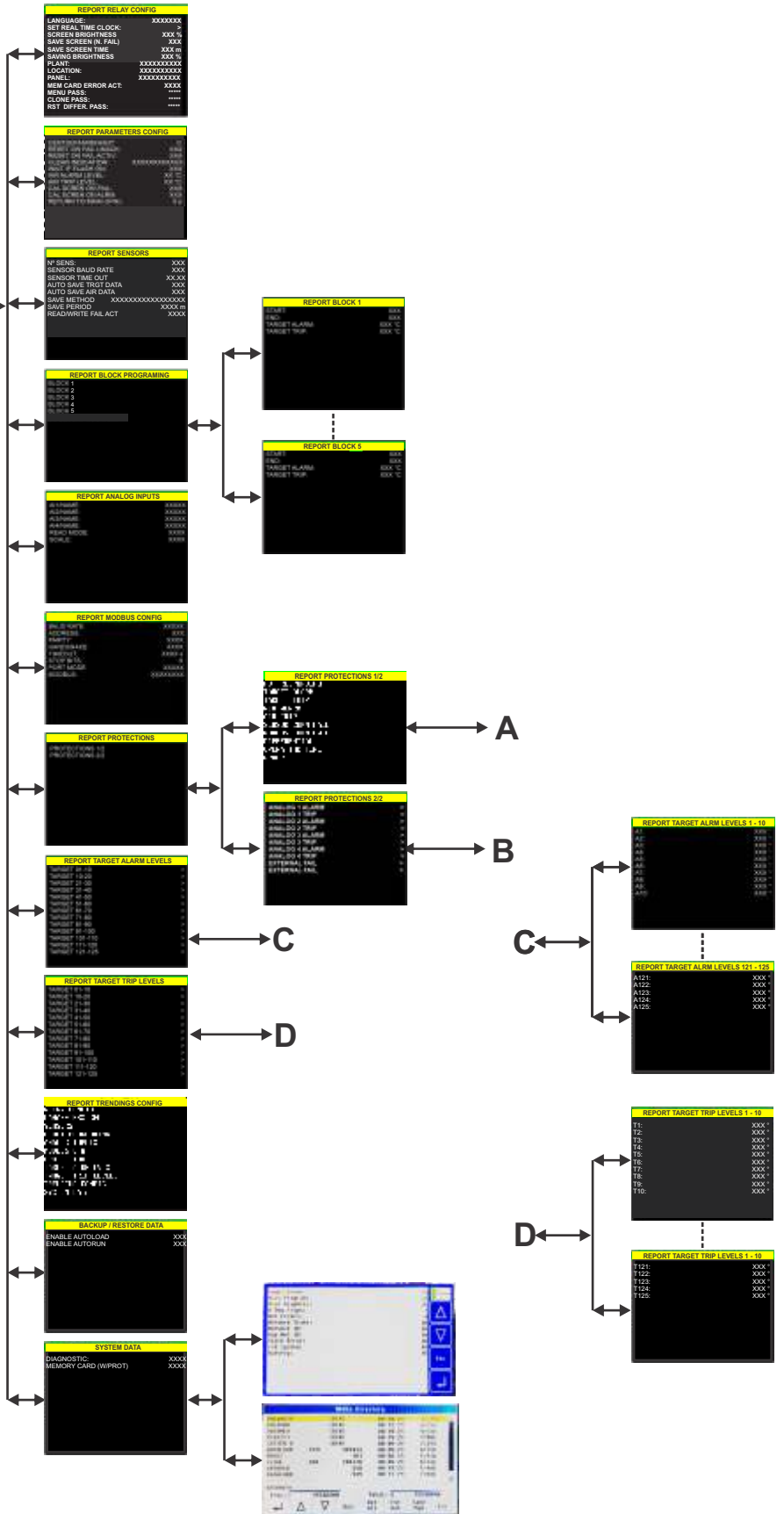
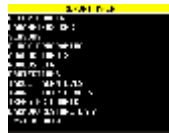

2/2 PROGRAM REPORT

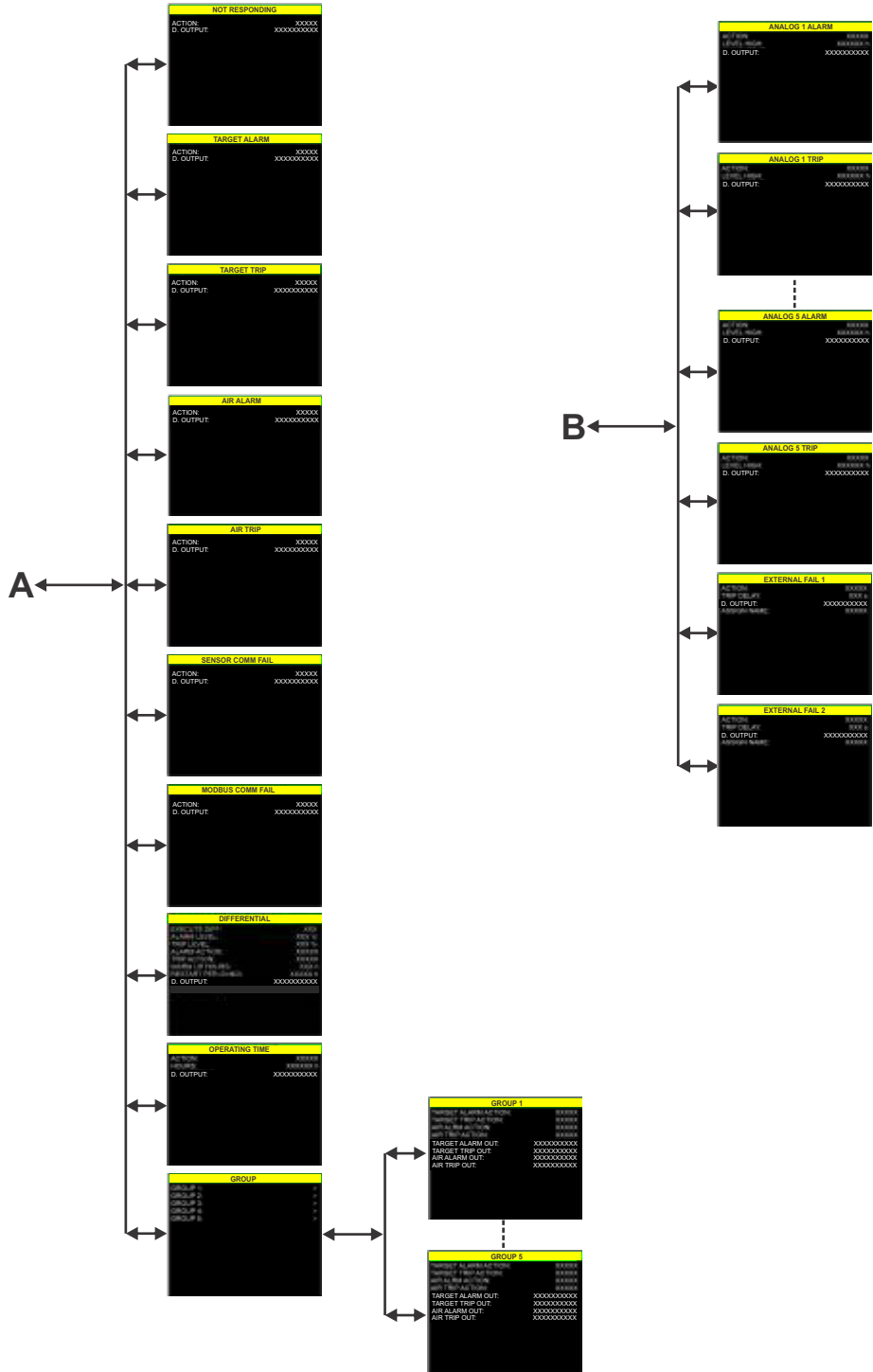

1/1 ETHERNET REPORT

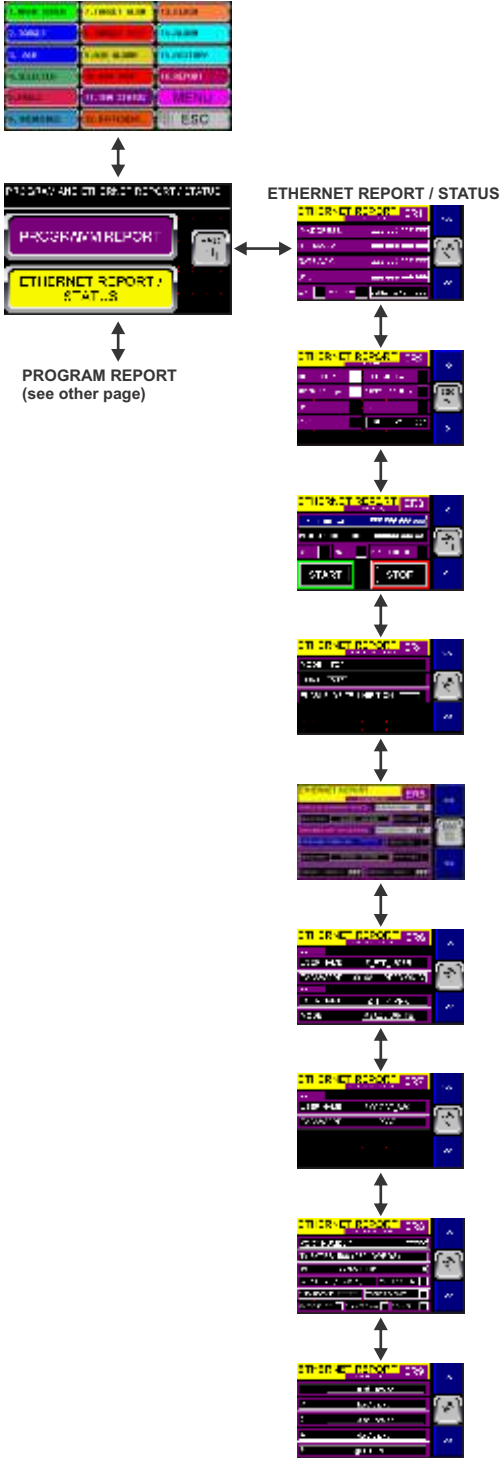

PROGRAMMING

PROGRAMMING MENU 2/2

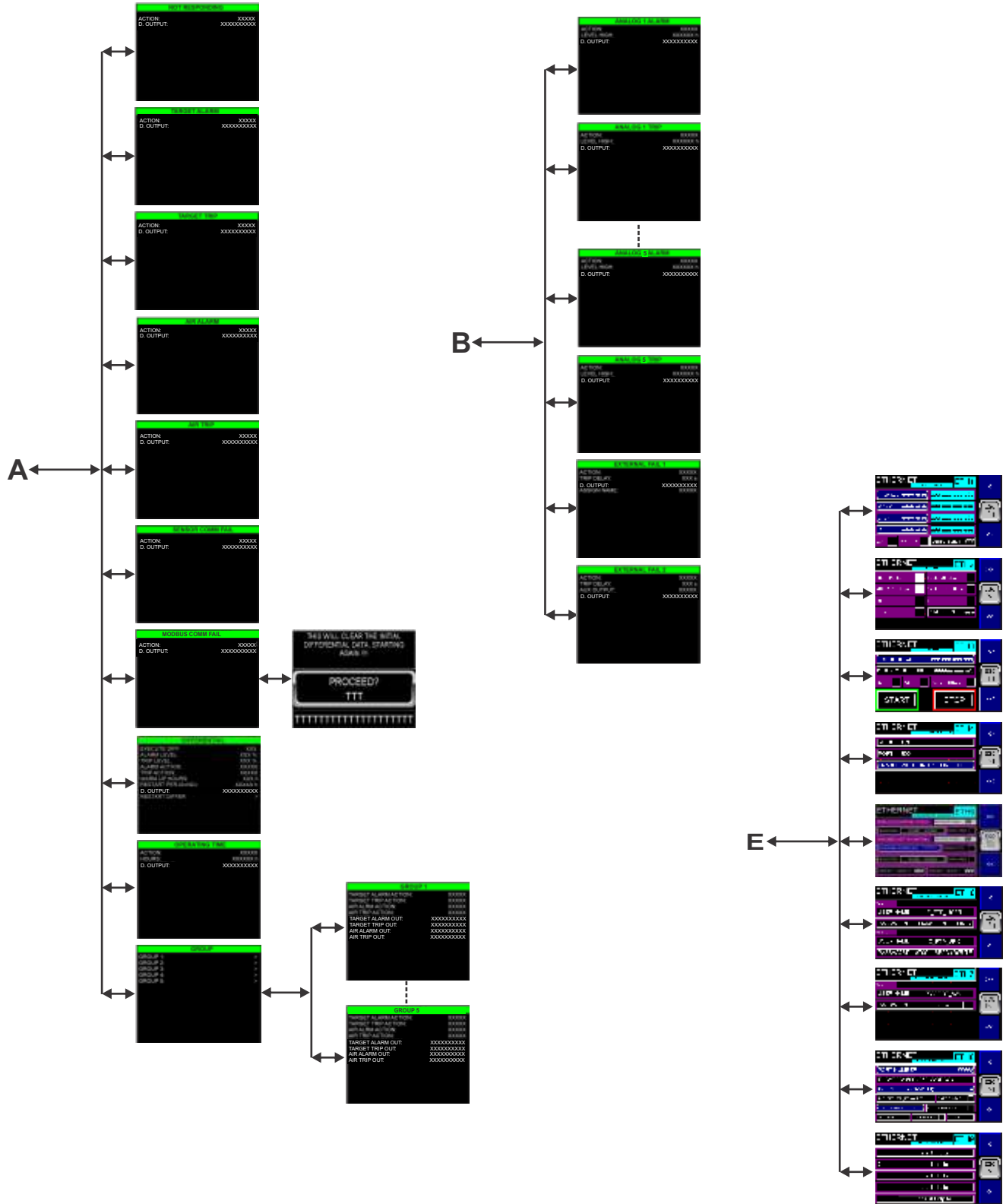

COMPUTER PARAMETERIZATION

ZYGGOT SUPERGER

Zyggot SuperGer is configuration software for the Zyggot family. The software is available free of charge on the Varixx website (<http://www.varixx.com.br>). The main screen of the program is shown next to it.

It is possible to parameterize the relay directly on it and also carry out complete programming on a relay and clone this relay to several others using a memory card or pendrive, as previously explained.

Install Superger Software on Windows computer. All files needed to run, including "Runtime" files, are already included in the package, meaning no additional software is required. Once installed it will be ready to run.



Note: With the Zyggot Superger you can easily clone the parameters of one relay to another (this can also be done via the uSD card). To program a series of relays with the same parameters, simply save them (using the «Save» button in the Superger software) and load the file later if necessary so that all the parameters are ready to «Send» to the relay.

1- The first step is to connect the relay. To do so, adjust the Modbus communication values on the relay and activate it in RS-232 mode. For details on how to activate Modbus, see the programming menu section. Use an RS-232 / RJ45 cable to connect the relay to a computer.

You can also use the Ethernet port and do all the programming via Ethernet communication. In this case, program the correct address as programmed on the relay in the Ethernet programming section (Modbus TCP/IP).



2- The next step in the software is to choose the language and working mode on the system configuration screen:

Once you have chosen the language, choose the Zyggot VZX or Zyggot V5FTA system relay. Once you have chosen the language and the type of relay, by clicking on its image, select the correct parameters for your computer (COM port 1, COM2, etc.) and the parameters that were programmed on the screen regarding Modbus in the relay (For example: Address: 1, Baudrate: 19200, Timeout: 1000 mS, Parity: None or in the case of Ethernet communication the IP Address, for example: 192.168.1.1). Make sure that Modbus is in the «Active» condition in the relay. Normally, once any parameters related to Modbus in the relay have been changed, it is necessary to turn the relay off and on for the changes to take effect, as these are parameters related to the relay BIOS.



COMPUTER PARAMETERIZATION

ZYGGOT SUPERGER

3- Once the parameters are correct and the relay has Modbus active. click on «**Connect**». The “Connected” sign should light up and the current parameter reading bar indicates their reading on the relay. This is due to the fact that you can save them and also indicate in red in each parameter window that is changed that the respective parameter will be changed if the «**Save**» key is used. You can also use the «**Receive**» key at any time to read the current parameters again. The window on the right shows all LOG messages to facilitate possible communication corrections.



4- When connection occurs, the connected lamp lights up. If the initial reading box is checked, immediately after connecting to the relay, all relay parameters will be transferred to the program. When finished, a success message is displayed. Use the save and open buttons to save information from a relay to a file on your computer and download the same information to other Zyggot relays.

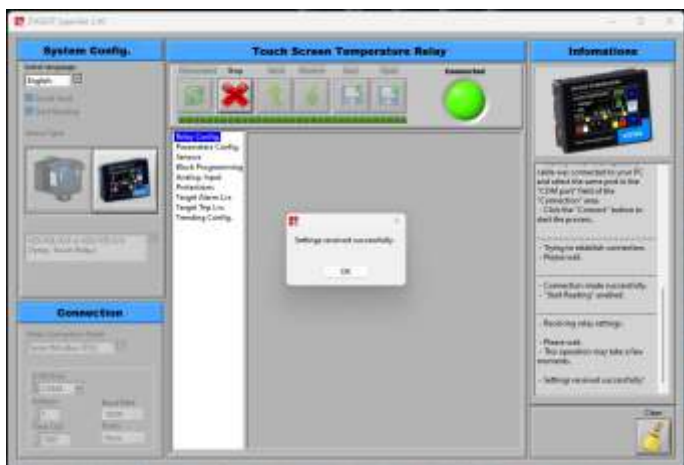

5- You are ready to program all parameters in the subsequent screens. Note that in each available window, when a parameter is changed, it turns red as a warning that it will be changed when sending data to the relay.



COMPUTER PARAMETERIZATION

ZYGGOT SUPERGER



COMPUTER PARAMETERIZATION

ZYGGOT SUPERGER

6- Once the parameters are correctly programmed, they can be saved to a disk file for later use using the «Save» button. You can also load previously saved files using the «Receive» button.

To send new data to the relay, use the «Send» button and at any time you can load the current relay parameters using the «Receive» button.

When sending data to the relay, at the end of sending the screen appears confirming that it was transmitted successfully.



SENSOR CONFIGURATION

ZYGGOT MANAGER SOFTWARE

Zyggot Manager is a configurator software that performs the addressing and testing of sensors. The software is available free of charge through the Varixx website <http://www.varixx.com> or <http://www.varixx.com.br>. The figure on the side shows the main screen of the software.

The program allows checking and setting important parameters before using the sensor on the network. It defines the sensor address, the emissivity of the target considered by the sensor and the distance between the sensor and the target.

Note: When using Unidex tape (known and constant emissivity over the years) the emissivity value 0.95 must be used.

The user-friendly interface allows viewing the temperature of the target and the sensor body in several ways:

- >> Through a graph it is possible to check the temperature measured in time. Scale endings can be changed with a mouse click.
- >> Temperature readings are also displayed in numerical form.

Through an “analog” marker, the full scale value can be changed.

You can also send a command for the sensor LED to flash. Unlike when connected to the relay, the sensor is lit and does not flash when connected to the computer.

Manager Software Main Window

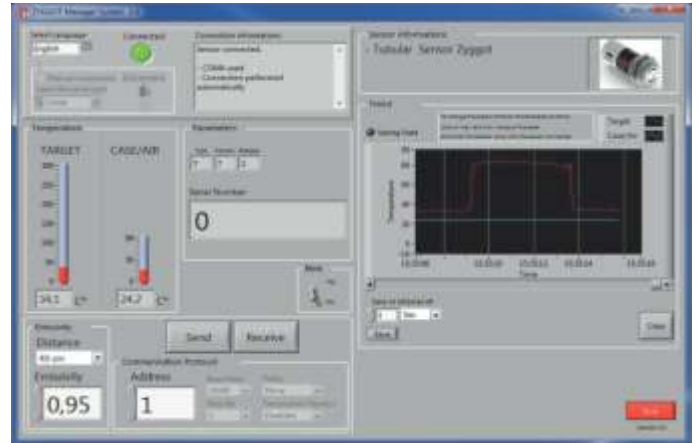

! CAUTION !

Do not connect the sensor to the PC while the other mini USB port is connected to the network.

NEVER connect two sensors simultaneously to the PC.

ALWAYS address one sensor at a time.

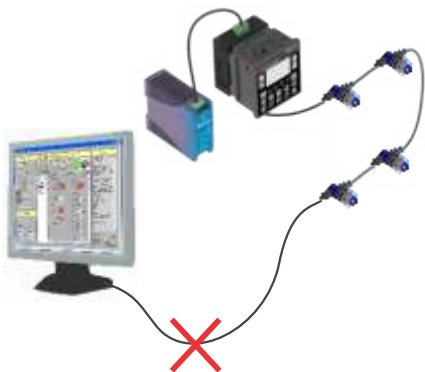

SENSOR CONFIGURATION

ADDRESSING OF SENSORS

In order not to compromise the proper functioning of the system, it is essential that all the sensor configuration instructions are followed, which will be explained below.

You must perform the configuration of each sensor even before installing them mechanically.

A) Install Zyggot Manager on your computer and run it in sequence;

B) Connect the configurator cable (supplied with the Zyggot Temperature Installation and Maintenance Case) to a USB port on the PC and one of the mini USB ports on the sensor.

Note: Unlike when the sensor is connected to the relay, the LED on the sensor body will stop flashing when connected to the computer. (On newer models this may be the other way around).

C) The program automatically detects the port referring to the sensor. If desired, it is also possible to manually select the sensor port. To do so, check the **Manual Connection** box, select the **COM** port referring to the sensor and press **Connect**. If there is no sensor connected to the selected port an error message will appear.



D) When connecting the sensor, the program will recognize it and will indicate by a green button that it is connected.

E) Set the sensor address (1 to 125). By default, all sensors leave the factory with address 1 and correct network parameters for communication with the Zyggot Temperature relay. When finished, press the **Submit** button.

Note: Each sensor must have a unique address on the network (from 1 to 125). When more than one sensor has the same address on the network, conflict occurs and the system does not operate.

Note: Wired sensor networks must have two terminating resistors: one on the first sensor in the network and one on the last. If other resistors are added to the network, network instability and non-functioning may occur. Varixx supplies physical termination resistors, encapsulated in a mini USB connector, for use in its sensor networks, simply by inserting it in the last sensor of the network and in a **ZTA** shunt connected to the first sensor.

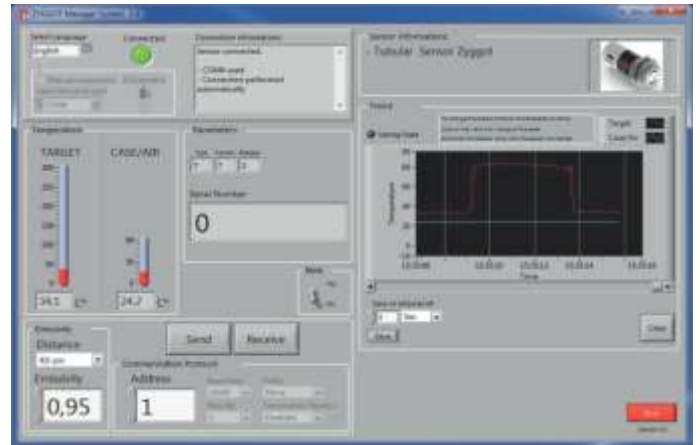

F) Enter the emissivity of the target and press the Submit button.

Note: When using Unidex tape (known and constant emissivity over the years) the emissivity value 0.95 must be used (which is the default emissivity value that the sensors leave from the factory).

G) Enter the distance the sensor will be from the target.

Note: The sensor comes from the factory configured for a distance of 40 cm.

H) Write down the sensor address, to have a map of its location on the panel or installation site. This is the address that will be shown on the relay screen referring to this sensor, for its correct identification.



FAIL SAFE SYSTEM

The Fail Safe System is a feature that allows the Zyggot relay to continue running in the event of certain types of "light" faults. These "mild" faults include:

- Loss of backup battery power.
- Registry RAM corruption, or firmware Flash corruption due to, for example, an excessive EMI event.

Nome	Data de modificação	Tipo	Tamanho
■ PLOTZ21	17/08/2021 09:09	Pasta de arquivos	
■ DATANEW	18/08/2021 16:53	Pasta de arquivos	
■ DATAMAN	12/08/2021 16:27	Pasta de arquivos	
■ DATAAUTO	12/08/2021 10:38	Pasta de arquivos	
■ DEFAULT.PGM	09/08/2021 18:32	Arquivo PGM	482 KB
■ AUTOLOAD.PGM	09/08/2021 18:33	Arquivo PGM	482 KB
■ CLONE.DAT	09/08/2021 18:33	Arquivo DAT	107 KB
■ DATACARD	17/08/2021 19:06	Arquivo	1 KB
■ DATAECK	18/08/2021 09:51	Arquivo	1 KB
■ BACKZ	06/08/2021 17:47	Arquivo	1 KB

The Fail Safe System should have a file structure on the Memory Card similar to the screen above.

Attention: With the exception of the files inside the directories, which can be freely altered or deleted, the files in the root directories cannot be modified or deleted, under penalty of interrupting the relay operation.

The failsafe system encompasses the following features:

- Manually back up current registry settings from battery-backed RAM to Flash memory.
- Manually restore registry settings from values previously saved in Flash to battery-backed RAM.
- Detect corrupted registry settings at startup and then automatically restore them from Flash memory.
- Detect corrupt or empty firmware in Flash memory at startup and then automatically load the AUTOLOAD.PGM file from removable media (Compact Flash or microSD).
- If an automatic registry restore or application load occurs, the Zyggot V5F will automatically be put into RUN mode.

The fail-safe system can be optionally supplied ready and configured by Varixx.

HOW TO MAKE...

HOW TO PROGRAM THE RELAY.

There are three ways: Through the HMI itself, or through the free PC configuration program, or through the Backup/Clone function from a memory card. To use the PC program, see the specific manual.

To program via the HMI:

Press «**Menu**», enter the correct password and follow the friendly sub-menus.

If the programming password is Zero, the menu will be entered directly, if it is different from zero, the screen will appear asking for the password. Enter it and press **ENTER**

Within the Config menu you can change this password. The factory password is 1.

To program with the PC Software, consult its specific manual.

To **Clone** the data with a memory card, use the Main menu option **12. Backup/Clone**. Backup the data of a previously programmed relay, using the «**Backup**» function

On a relay without programming, use the «**Restore**» function in this menu.

HOW TO CHOOSE LANGUAGE.

For screens and menus, 3 languages are available on the relay, English, Portuguese and Spanish. Any fourth language can be requested at purchase (Custom) by prior agreement with the manufacturer.

To select the language:

Enter Menu, Relay Config Submenu, Select the item Language or Language, press enter, Select the required language by pressing Enter again to confirm and ESC to exit the menu.

HOW TO CONFIGURE THE SENSORS (“SENSOR” MENU).

! Enter the Programming Menu and then the Sensors submenu.

! Choose the item to change and press **ENTER**,

! Choose the option in the list for each parameter or enter the data if it is numeric,

! Press **ENTER** to confirm,

! Choose the next item and repeat the operation.

HOW TO CHANGE THE PROGRAMMING PASSWORD (MENU “RELAY CONFIG”).

! Enter the Main Menu and then the Relay Config submenu.

! Choose the item to change and press **ENTER**.

! **Menu Pass**: Enter the new password if you want to change it. The factory password is 1. If “0” is entered as the new password, you can enter the Menu without a password by simply pressing the Menu key.

! Press **ENTER** to confirm.

HOW TO NAME THE PLANT, LOCATION AND PANEL AND ENTER THE OPERATION START DATE.

For information purposes, the above items can be named with up to 5 characters. Proceed as follows:

Enter Menu, Relay Config Submenu,

Select the desired item,

Press **Enter**, Enter the new data, using the numeric keys, press Enter to confirm and **ESC** to exit the menu.

HOW TO CHECK SENSORS NOT RESPONDING.

To view the non-responding sensor map, press **11.NOT REP.** to call up the NR1 screen and use the arrows to see all the NR screens if necessary. Sensors not responding will be squared in violet.

If during a reading attempt there is no response, the indication will be activated on the main screen and all indicators of the sensors not responding, on screens NR1 to NR9 will be activated, since there was no response. In this case, all temperature readings will be indicated with 8888, as invalid. In this case, there will be no trip or alarm by temperature, but by Not Responding if it is enabled.

HOW TO SET THE REAL TIME CLOCK.

If necessary, due to daylight saving time or other reasons, proceed as follows:

Enter Menu, Relay Config Submenu, Select the Set Real Time Clock item, Press **Enter**, Enter the new data, using the small arrows under the display, press **Enter** to confirm and **ESC** to exit the menu.

HOW TO SET THE PARAMETERS (“PARAMETERS” MENU).

! Enter the Main Menu and then the Config Parameters submenu.

! Choose the item to change and press **ENTER**,

! Choose the option in the list for each parameter or enter the data if it is numeric,

! Press **ENTER** to confirm,

! Choose the next item and repeat the operation.

HOW TO SET UP MODBUS COMMUNICATION. (“MODBUS” MENU).

The names for this menu are the classic ones and there is nothing to explain, since the user must know the protocol to use Modbus communication. The port for Modbus communication is RJ1.

Enter the Programming Menu and then the Modbus CFG submenu.

Choose the item to change and press **ENTER**,

Choose the option in the list for each parameter or enter the data if it is numeric.

Press **ENTER** to confirm,

Choose the next item and repeat the operation.

The parameters are as follows:

Baud Rate, Address, Parity, Handshake, Timeout, Port Mode (RS232 or RS 245), **Stop Bits and Modbus** (Active, Inactive)

HOW TO MAKE...

HOW TO CONFIGURE THE CURVES (TRENDING). (MENU "CONFIG TRENDING").

Curves referring to temperatures and analog inputs must be configured in this menu.

Enter the Main Menu and then the Config Trending submenu.

Choose the item to change and press **ENTER**,

Choose the option in the list for each parameter or enter the data if it is numeric or alphanumeric.

Press **ENTER** to confirm,

Choose the next item and repeat the operation.

The parameters are as follows:

Scale: Enter the scale to use for all curves.

Index Mode: (Display, Menu). If Display is chosen, the operator must enter the indices of each curve directly on the curve screens as explained in the Operation chapter. If Menu is chosen, the indexes used will be those inserted below.

HMI Reset: (No, Yes). Enables or not the possibility of the operator being able to reset or restart each curve using the ESC command (to do this, hold down the ESC key for 3 seconds and the curve will restart). Index 1A-5A to Index 6C-10C.

(1 to 129): enter the sensor numbers from 1 to 125. These are the signals that will be used in the corresponding curves if Menu mode is chosen in Index Mode. Curves from indexes 1 to 5 (A, B and C, i.e. three curves each trending screen) will be shown on trending screens 3 to 7 and curves from indexes 6 to 10 will be shown on screens 8 to 12.

For the T18 screen, which is retentive and can save time curves in Excel format on the memory card, select the **Enable Retentive** item and choose «**Yes**».

See more details in the Programming chapter.

HOW TO DEFINE EMISSIVITIES FOR EACH TARGET. (MENU "SENSOR").

The emissivity indices for each target can be defined in the programming of the sensor itself, where the emissivity and the sensor address are entered, using the free PC program available on our website. See specific manual for the sensor programming software.

HOW TO SET ALARM LEVELS FOR TARGET OVERTEMPERATURE. (MENU "TARGET ALRM LEVELS").

Target alarm levels can be defined in block programming, as explained above. A single group with all sensors can be programmed if the level is the same for all or up to 5 different levels, one for each block. Another way, even after programming by blocks and if you want to individually change some or all of the levels, is through the "Alrm Target Levels" menu.

Enter the Main Menu and then the Alrm Target Levels submenu.

A menu with 13 submenus is displayed, each containing up to 10 levels.

Select the level to change and enter the value.

Press **ENTER** to confirm,

Choose the next item and repeat the operation.

HOW TO CONFIGURE ANALOG INPUTS. (MENU "ANALOG INPUT").

For the analog inputs, you can enter the name of each one (5 characters), facilitating the identification, choosing the reading mode and the scale.

Enter the **Main Menu** and then the Input submenu **Analog Inputs**.

Choose the item to change and press **ENTER**,

Choose the option from the list of each parameter or enter the data if it is numerical or alphanumeric.

Press **ENTER** to confirm,

Choose the next item and repeat the operation.

HOW TO SET ALARM LEVELS FOR TARGET OVERTEMPERATURE. (MENU "TRIP TARGETED LEVELS").

Target tripping levels can be defined in block programming, as explained above. A single group with all sensors can be programmed if the level is the same for all or up to 5 different levels, one for each block. Another way, even after programming by blocks and if you want to individually change some or all of the levels, is via the "Target Trip Levels" menu.

Enter the Main Menu and then the Trip Target Levels submenu.

A menu with 13 submenus is displayed, each containing up to 10 levels.

Select the level to change and enter the value.

Press **ENTER** to confirm,

Choose the next item and repeat the operation.

HOW TO DEFINE THE ACTIONS AND AUXILIARY RELAYS ACTIVATED FOR EACH PROTECTION. (MENU "PROTECTIONS").

The action to be taken, which can be: Nothing (disables the protection), Log (the event is entered in the history and alarms list but no output relay is activated (not even the Alarm relay or the Trip relay), Alarm (the Alarm output relay is activated) and Trip (the "Alarm" and "Trip" outputs are activated).

There are 2 protection submenus: Protections 1/2 and Protections 2/2.

The first contains the general protections, the second the protections referring to analog inputs and external faults.

Enter the Main Menu and then the Protections submenu.

A menu with 3 submenus is displayed.

Select one of them and press **ENTER**.

Select the protection sub-item to be programmed and press **ENTER**,

Select the action and auxiliary relay.

SUPERVISORY SOFTWARE

ZYGGOT THERMOGRAPHY 3.00 SUPERVISORY SOFTWARE

Zyggot Supervisory - **Version 3.00** and higher, is a program that communicates with the relay and presents sensor readings on the computer screen just like a supervisory system. The software is available free of charge through the Varixx website (<http://www.varixx.com.br>).

Install the Software on your Windows computer. All files needed to run, including "Runtime" files, are already included in the package, meaning no additional software is required. Once installed it will be ready to run.

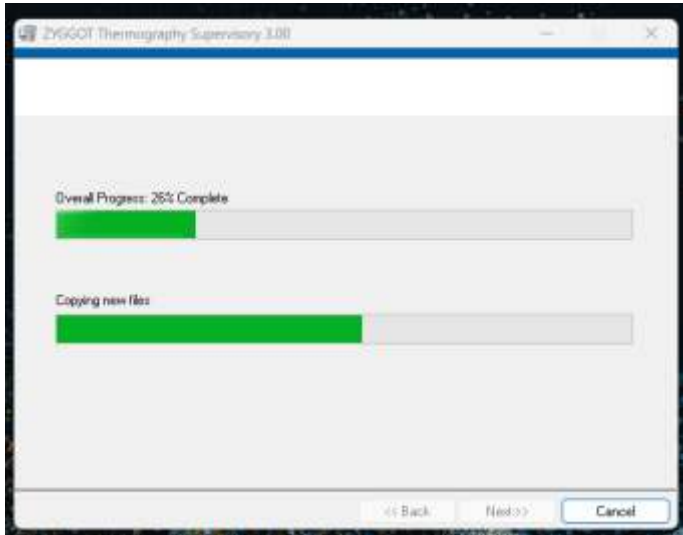

1- The first step is to connect to the relay. To do so, adjust the Modbus communication values on the relay and activate it in RS-232 mode. For details on how to activate Modbus see the programming menu section. Use an RS-232 / RJ45 cable to connect the relay and a computer.

You can also use the Ethernet port and do all programming via Ethernet communication. In this case, program the correct address as programmed in the relay in the Ethernet programming part (Modbus TCP/IP). Use an Ethernet cable in this mode.

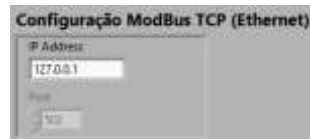

Note: This software is not required for system operation. It is a bonus that the user can use to check the system or not.

2- The first step is to press the **Configure Modbus** button. You can see the initial screen "Configure Modbus". Once you have chosen the connection mode, namely a) **Modbus RTU** (Serial) or b) **Modbus TCP** (Ethernet) (in the top selection box, under the phrase «Select the communication medium) and entered the parameters corresponding to those entered in the relay you can click on the «Connect» button and if the connection occurs, the «Connected» flag will turn from red to green.



3- Once connected, click on the "Overview 1" button or the "Overview 2" button. In the case of the first screen, you can observe the target and air temperatures (sensor body) of each sensor responding on the network and a description of the same case inserted.

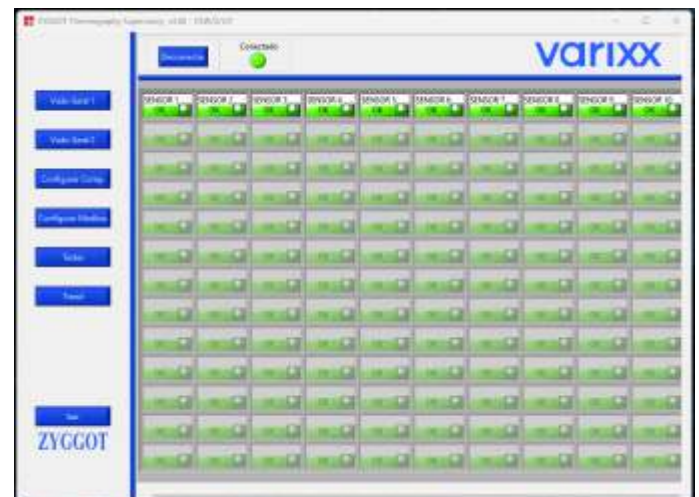
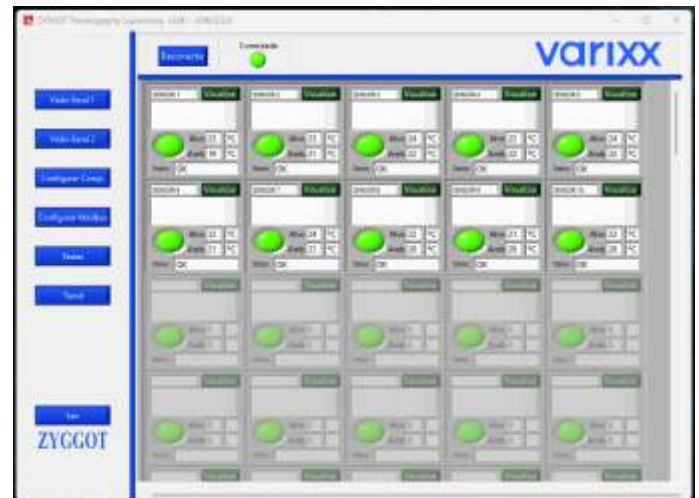

SUPERVISORY SOFTWARE

SOFTWARE SUPERVISÓRIO ZYGGOT THERMOGRAPHY 3.00

3- Once connected, click on the «**Overview 1**» button, you can observe the target and air temperatures (sensor body) of each sensor responding on the network and a description of the same case inserted.

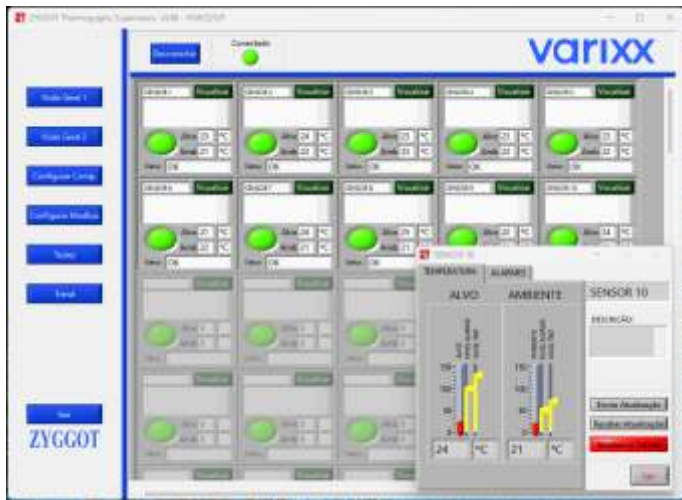

4- Click on the «**View**» button or on the lens symbol for each of the sensors. A window opens with alarm adjustment sliders and Alarm and Trip level parameters, which can be adjusted using the mouse and sent to the relay by clicking the “Send update” button. Note that when changing the slide its color changes from blue to yellow until «**Update**» is commanded. This function is also used to test the operation of the Alarm or Trip by adjusting levels below the current reading levels indicated in red. By clicking on the «**Alarms**» tab in this window for each sensor, you can also change the Alarm and Trip levels through the corresponding windows, using the mouse or by entering the values using the keyboard. Note that the color of the window changes to red until the “Send update” command is made. This way you can change relay parameters in real time.

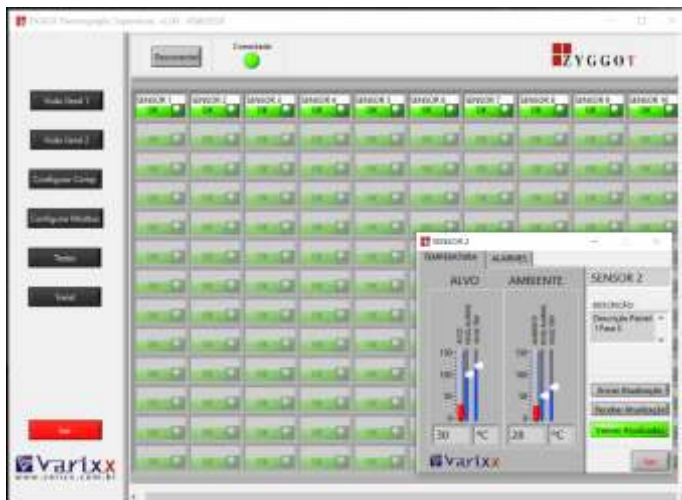

5- Click on the «**Configure Comp**» button in the menu on the left and the following screen opens with 3 options, namely «**Sensors**», «**Thermometers**» and «**Alarm Levels**»

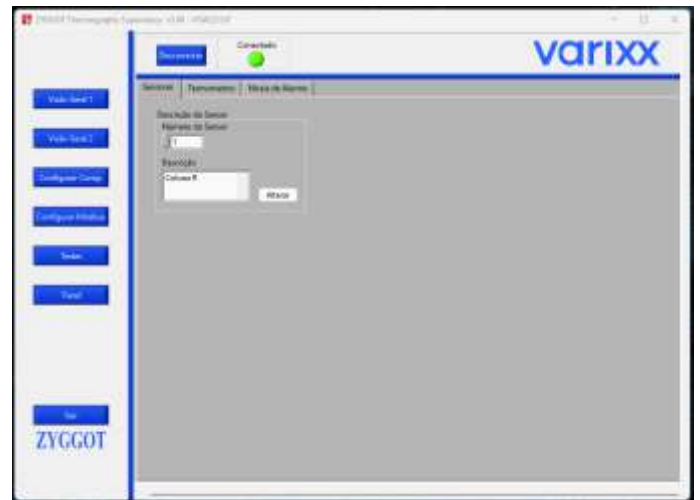

6- Click on the «**Sensors**» tab and you can enter a description of each of the sensors, for example «**Column R**» etc. Click on the Thermometers tab and you can change the scales of each thermometer on the graph. Click on the “Alarm Levels” tab and you can change the waiting time to be notified of a change in level.

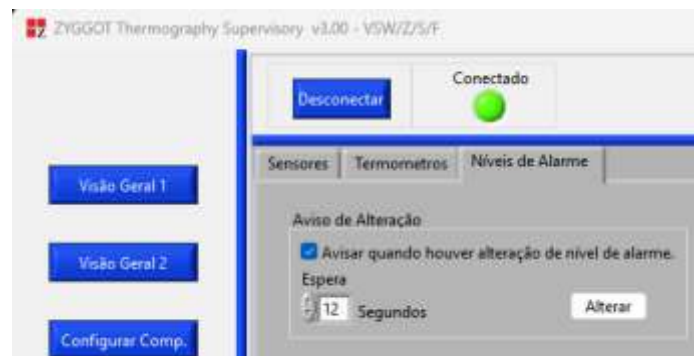

6- Click on the «**Test**» tab and you can change the LED blinking mode on each sensor, from blinking to continuous or vice versa to locate it on the panel or to test whether it is responding correctly on the network. Zero commands the change in all sensors.



SUPERVISORY SOFTWARE

SOFTWARE SUPERVISÓRIO ZYGGOT THERMOGRAPHY 3.00

6- Click on the «Trend» button and you can see the screen on which you can plot the Target and Air temperatures of up to 10 sensors simultaneously.

Through the corresponding windows you can choose the sensors to be plotted, whether **Target** and/or **Air** and the trace color of each one. To change the color, click on the small colored square for each stroke and choose the new color.

In the lower window on the left side you can choose the period for automatic saving of readings in a CSV file which can be opened in Excel.

You can also command manual saving at any time using the "Save" key. Using the "Save" button, you can save the data read so far in Excel CSV format for later documentation, and you can even generate the corresponding graphs. Once clicked on save a window to choose the destination and file name will appear.

In the last figure, below, you can see an example file, with 5 sensors and Target and Air temperatures for each of the readings.

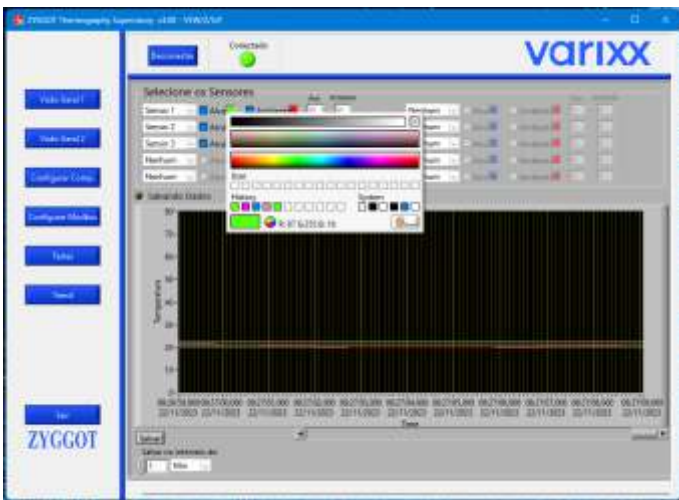
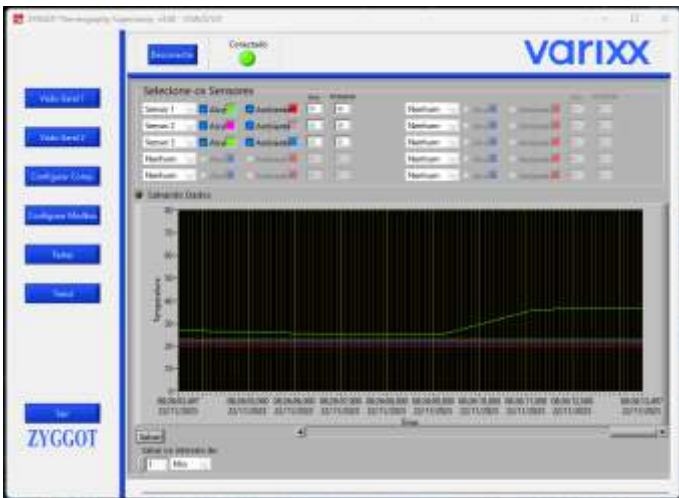
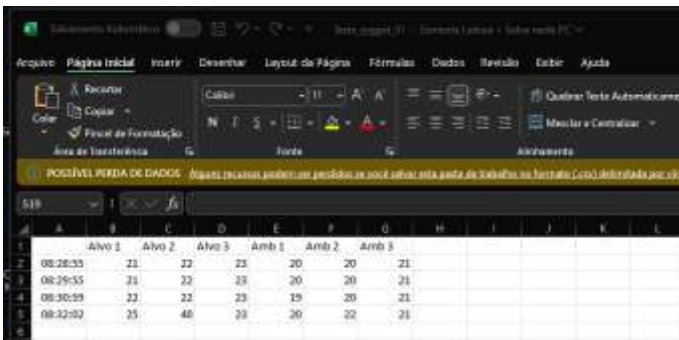
The screenshot shows an Excel spreadsheet with the following data:

	A	B	C	D	E	F	G	H	I	J	K	L
1		Alvo 1	Alvo 2	Alvo 3	Amb 1	Amb 2	Amb 3					
2	08:28:55	21	22	23	20	20	21					
3	08:29:55	21	22	23	20	20	21					
4	08:30:59	22	22	23	19	20	21					
5	08:32:02	25	48	33	30	32	21					

A complete explanation of the Modbus RTU or ASCII protocol is not within the scope of this manual. It is assumed that the user who will apply the same using this protocol, must have sufficient knowledge for this.

Also, in this manual we will only provide the basic addresses of the memory map to perform the usual operations of reading faults and others. Any parameter programming must be performed on the device itself, as it is normally done only once, during Startup.

Next, there will be a short introduction to the Modbus communication network before the memory map presentation.

Devices communicate using a master-slave technique, in which only one device (the master) can initiate transactions (called 'queries'). The other devices (the slaves) respond by supplying the requested data to the master, or by taking the action requested in the query. Typical master devices include host processors and programming panels. Typical slaves include programmable controllers, motor controllers, load monitors etc, see Fig

The master can address individual slaves. Slaves return a message (called a 'response') to queries that are addressed to them individually. The Modbus protocol establishes the format for the master's query by placing into it the device address, a function code defining the requested action, any data to be sent, and an error checking field. The slave's response message is also constructed using Modbus protocol. It contains fields confirming the action taken, any data to be returned and an error-checking field. If an error occurred in receiving the message, or if the slave is unable to perform the requested action, the slave will construct an error message and send this as its response, see Fig.

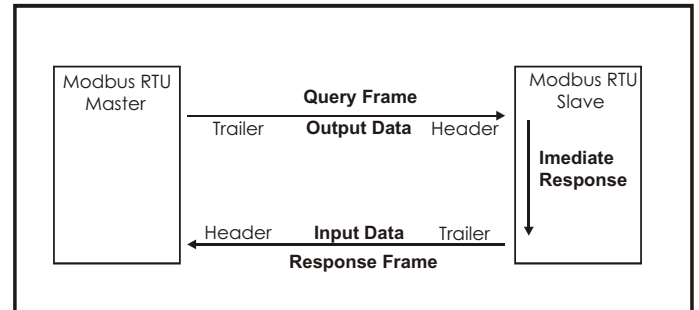
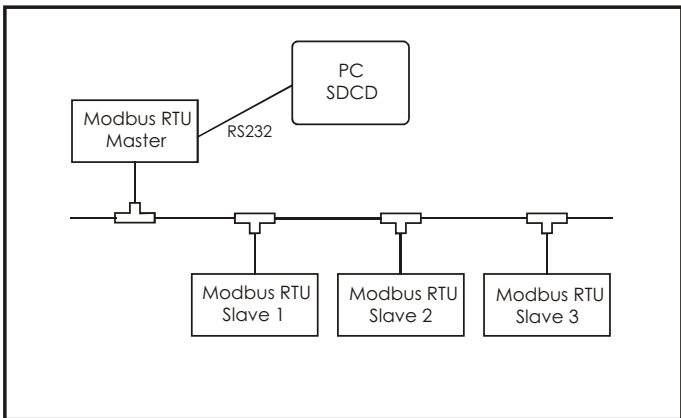

Address field

The address field of a message frame contains eight bits. The individual slave devices are assigned addresses in the range of 1 - 247. A master addresses a slave by placing the slave address in the address field of the message.

When the slave sends its response, it places its own address in this address field of the response to let the master know which slave is responding.

Function field

The function code field of a message frame contains eight bits. Valid codes are in the range of 1 - 6, 15, 16 and 23. When a message is sent from a master to a slave device, the function code field tells the slave what kind of action to perform.

Examples are:

- to read the ON/OFF states of a group of inputs;
- to read the data contents of a group of parameters;
- to read the diagnostic status of the slave;
- to write to designated coils or registers within the slave.

When the slave responds to the master, it uses the function code field to indicate either a normal (error-free) response or that some kind of error occurred (called an exception response). For a normal response, the slave simply echoes the original function code. For an exception response, the slave returns a code that is equivalent to the original function code with its most significant bit set to a logic 1.

In addition to its modification of the function code for an exception response, the slave places an unique code into the data field of the response message. This tells the master what kind of error occurred, or the reason for the exception.

The master device's application program has the responsibility of handling exception responses. Typical processes are to post subsequent retries of the message, to try diagnostic messages to the slave and to notify operators. Additional information about function codes and exceptions comes later.

Data field

The data field is constructed using sets of two hexadecimal digits (8 bits), in the range of 00 to FF hexadecimal.

The data field of messages sent from a master to slave devices contains additional information which the slave must use to take the action defined by the function code. This can include items like discrete and register addresses, the quantity of items to be

handled and the count of actual data bytes in the field.

For example, if the master requests a slave to read a group of holding registers (function code 03), the data field specifies the starting register and how many registers are to be read. If the master writes to a group of registers in the slave (function code 10 hexadecimal), the data field specifies the starting register, how many registers to write, the count of data bytes to follow in the data field, and the data to be written into the registers.

If no error occurs, the data field of a response from a slave to a master contains the data requested. If an error occurs, the field contains an exception code that the master application can use to determine the next action to be taken.

CRC Error checking field

The error checking field contains a 16 bit value implemented as 2 bytes. The error check value is the result of a Cyclical Redundancy Check (CRC) calculation performed on the message contents.

The CRC field is appended to the message as the last field in the message. When this is done, the low-order byte of the field is appended first, followed by the high-order byte. The CRC high-order byte is the last byte to be sent in the message. Additional information about CRC calculation are found in this manual.

Functions

Standard MODBUS function codes.

Function name	Function code
Read Coil (Bit) Status	1 (01h)
Read Input Status	2 (02h)
Read Holding Registers	3 (03h)
Read Input Registers	4 (04h)
Force Single Coil (Bit)	5 (05h)
Force Single Register	6 (06h)
Force Multiple Coils (Bits)	15 (0Fh)
Force Multiple Registers	16 (10h)
Force/Read Multiple Holding Registers	23 (17h)

Read Input Status

Read the status of digital read-only information.

EXAMPLE : Request the digital input 2. Assuming that It is no active.

Status: Modbus no = 2.

Request message.

Field name	Hex value
Slave address	01
Function	02
Start address HI	00
Start address LO	02
Number of Inputs HI	00
Number of Inputs LO	01
CRC LO	18
CRC HI	0A

Response message.

Field name	Hex value
Slave address	01
Function	02
Byte count	01
Input no.2 (02h)status	00
CRC LO	A1
CRC HI	88

Read Holding Registers

Read the value of analogue changeable information.

Example, requesting some Voltage, Frequency and Current. Their values are 400.0 V, 60 Hz and 15.5 A.

400.0V, unit 0.1V - 4000 (0FA0h)

60Hz unit 1Hz - 60 (003Ch)

15.5A, unit 0.1A - 155 (009Bh)

Request message.

Field name	Hex value
Slave address	01
Function	0
Start address HI	00
Start address LO	00
Number of Registers HI	00
Number of Registers LO	03
CRC LO	05
CRC HI	CB

Response message

Field name	Hex value
Slave address	01
Function	03
Byte count	06
Reg no. 0, (0h) data HI	0F
Reg no. 0, (0h) data LO	A0
Reg no. 1, (1h) data HI	00
Reg no. 1, (1h) data LO	3C
Reg no. 2, (2h) data HI	00
Reg no. 2, (2h) data LO	9B
CRC LO	20
CRC HI	34

Read Coil Status

Read the status of digital changeable parameters.

EXAMPLE

Requesting the coil (Bit) 29 input state. Suppose it is On

30 input: Modbus no = 29 (1Dh)

On = Yes = 1 Coil = 0001

1 byte of data: Byte count=01

Request message.

Field name	Hex value
Slave address	01
Function	01
Start address HI	00
Start address LO	1D
Number of Coils HI	00
Number of Coils LO	01
CRC LO	6D
CRC HI	CC

Response message.

Field name	Hex value
Slave address	01
Function	01
Byte count	01
Coil no.29 (1Dh) status	01
CRC LO	90
CRC HI	48

Read Input Registers (Offset=0000 // Reference= 30001)

Read the contents of analogue read-only information.

EXAMPLE

Request the value of the %Ai11 Modbus - Suppose It is 452.0. (Offset=0000 // Reference= 30000)

It has a long representation. 2 registers are used (30011 high word and 30012 low word)

452.0, unit 0.1 - 4520 (000011A8h).

Request message.

Field name	Hex value
Slave address	01
Function	04
Start address HI	00
Start address LO	0A
Number of Registers HI	00
Number of Registers LO	02
CRC LO	51
CRC HI	C9

Response message.

Field name	Hex value
Slave address	01
Function	04
Byte count	04
Reg no. 10 (0Ah) data HI	00
Reg no. 10 (0Ah) data LO	00
Reg no. 11 (0Bh) data HI	11
Reg no. 11 (0Bh) data LO	A8
CRC LO	F6
CRC HI	6A

Force Single Coil (Bit) (Offset=0000 // Reference= 00001)

Set the status of one changeable digital parameter.

EXAMPLE

Set one command to ON. This will cause the some kind of action.

Modbus no = 1 - address LO 1 (01h)

Run = 1 - 0 Data HI = 255 (0FFh), Data LO = 00 (00h)

Request message.

Field name	Hex value
Slave address	01
Function	05
Start address HI	00
Start address LO	01
Data HI	FF
Data LO	00
CRC LO	DD
CRC HI	FA

Response message.

Field name	Hex value
Slave address	01
Function	05
Start address HI	00
Start address LO	01
Data HI	FF
Data LO	00
CRC LO	DD
CRC HI	FA

Force Multiple Coil (Offset=0000 // Reference= 00001)
Set the status of multiple digital changeable parameters.

EXAMPLE

Set one flag to ON and other to ON. This will cause some actions or change parameters. Coil no. = 0-1 Reset -> 1 // Run = 1 -> 00000011 (03h)

Request message.

Field name	Hex value
Slave address	01
Function	0F
Start address HI	00
Start address LO	00
Number of Coils HI	00
Number of Coils LO	02
Byte count	01
Coil no. 0-1 status (0000 0011B)	03
CRC LO	9E
CRC HI	96

Response message.

Field name	Hex value
Slave address	01
Function	0F
Start address HI	00
Start address LO	00
Number of Coils HI	00
Number of Coils LO	02
CRC LO	D4
CRC HI	0A

Force Multiple Register (Offset=0000 // Reference= 40001)
Set the contents of multiple changeable analogue param.

EXAMPLE

Set the register 40018 (Modbus N° 17) to 25.0 (250 / 10) and 40019 (Modbus N° 18) to 55. 25.0, unit 0.1 -> -250 (00FAh) // 55, unit 1% -> 55 (0037h)

Request message.

Field name	Hex value
Slave address	01
Function	10
Start address HI	00
Start address LO	11
Number of Registers HI	00
Number of Registers LO	02
Byte count	04
Data HI reg 17 (11h)	00
Data LO reg 17 (11h)	FA
Data HI reg 18 (12h)	00
Data LO reg 18 (12h)	37
CRC LO	52
CRC HI	88

Response message.

Field name	Hex value
Slave address	01
Function	10
Start address HI	00
Start address LO	11
Number of Registers HI	00
Number of Registers LO	02
CRC LO	11
CRC HI	CD

Force/Read Multiple Register (Offset=0000 // Reference= 40001)

Set and read the contents of multiple analogue changeable parameters in the same message.

EXAMPLE

Set one parameter to 2 (40022 = Modbus N° 21) and other to 1 (40023 = Modbus N° 22) and read others two. They are 1450 and 17000.

1450, unit 1 -> 1450 (05AAh)
17000, unit 1 -> 17000 (4268h)

Request message.

Field name	Hex value
Slave address	01
Function	17
Start read address HI	00
Start read address LO	03
Number of read Regs HI	00
Number of read Regs LO	02
Start write address HI	00
Start write address LO	15
Number of write Regs HI	00
Number of write Regs LO	02
Byte count	04
Data HI Reg 21 (15h)	00
Data LO Reg 21 (15h)	02
Data HI Reg 22 (16h)	00
Data LO Reg 22 (16h)	01
CRC LO	62
CRC HI	77

Response message.

Field name	Hex value
Slave address	01
Function	17
Byte count	04
Reg no. 3, (3h) data HI	05
Reg no. 3, (3h) data LO	AA
Reg no. 4, (4h) data HI	42
Reg no. 4, (4h) data LO	68
CRC LO	E8
CRC HI	85

Exception response message.

Field name	Hex value
Slave address	01
Function	84
Exception code	02
CRC LO	C2
CRC HI	C1

Exception codes.

Exc. code	Name	Description
01	Illegal function	This unit doesn't support the function code.
02	Illegal data address	The data address is not within its boundaries.
03	Illegal data value	The data value is not within its boundaries.
06	Busy	The unit is unable to perform the request at this time. Retry later.

Reference	Maximum Range	Modbus Reference	Modbus Command(s)	ModbusOffset
%I1	2048	10001	Read Input Status (2)	00000
%IG1	256	13001		03000
%S1	13	14001	Read Flag Status (1) Force Flag (5) Force Multiple Flags (15)	04000
%K1	4	15001		05000
%Q1	2048	00001		00000
%M1	2048	03001	Read Input Register (4)	03000
%T1	2048	06001		06000
%QG1	256	09001	Read Holding Register (3) Load Register (6) Load Multiple Registers (16)	00000
%AI1	512	30001		00000
%AIG1	32	33001		03000
%SR1	192	34001		04000
%Aq1	512	40001	Read Holding Register (3) Load Register (6) Load Multiple Registers (16)	00000
%R1	8192 (1024 Retentive)	43001		03000
%AQG1	32	46001		06000

How to Connect a MODBUS slave device.

The physical device characteristics of the particular slave device determines the communications parameters required for connection. MODBUS is a multidrop communications protocol, (software), but typical RS-232 serial connections are not. RS-232 is basically a point-to-point hardware protocol with the transmit line of one device connected to the receive line of another device. Various combinations of protocol converters and/or modems may be used to multidrop RS-232 data links. Additionally, some serial cards may be configured to support 20 mA current loop for multidrop operation.

If a single slave device is to be connected, standard RS-232 hardware may be used. Depending upon the requirements of the master device, certain control signals may be required. These are typically RTS/CTS, (pins 4&5), or DTR/DSR/DCD, (pins 6,8 & 20). The ZYGGOT supports these control signals.

Comm Port Buffering

The ZYGGOT firmware maintains a Transmit Buffer and a Receive Buffer. When a Send or Receive task is performed, data is transferred between the appropriate buffer and the program's registers.

For a Comm Port Transmit element, the TX Count word contains the number of characters moved from the program registers to the transmit buffer. This number can be less than the requested number if the comm port buffer is full.

For a Comm Port Receive element, the RX Count word contains the number of characters moved from the receive buffer in the program area. This number can be less than the requested number if the comm port buffer contains fewer characters than requested.

Serial Port

The serial port physically present on the ZYGGOT unit is referred to as COMM1.

Handshaking

Handshaking is a method whereby the destination end of a transmission can control how much and when data is sent to it.

NOTE: For purposes of this discussion, source end is

defined as the unit which is transmitting data. Destination end is defined as the unit which actually receives the data.

Handshaking is configured on ZYGGOT V5F menu. There are five (5) possible types of handshaking:

NONE -- There is no handshaking. The source unit sends as many data bytes as it can as fast as possible for a given baud rate. No consideration is given to the capabilities of the destination end.

XON/XOFF -- (Also called software handshaking) The destination end keeps track of how many characters it has received and the size of its internal buffers. If the buffer gets full or the unit is otherwise unable to receive further characters, it must transmit the XOFF (transmit off) character. The source end must then stop transmitting data until a subsequent XON character is sent by the destination end.

Because there is some heavy software overhead involved, the timing of transmissions is variable. The destination must first determine that it is full and then transmit the XOFF signal. The source end must read the XOFF signal and react to it. In the mean time, several additional data bytes can be sent. It is up to the destination end to ensure that it sends the XOFF signal soon enough that the buffer is not overrun.

The XON and XOFF characters are predefined by the ASCII character set. XON is 11 hex or 17 decimal. XOFF is 13 hex or 19 decimal. The XON/XOFF handshaking is most often used where only ASCII values are being sent. XON/XOFF can not be easily used where binary data is involved, because the XON/XOFF codes are also valid binary codes.

Note that XON/XOFF handshaking usually implies a full duplex (both ends may transmit simultaneously) communications channel as the destination end needs to transmit the XOFF characters at any time (including in the middle of a transmission from the source end).

The advantage to XON/XOFF handshaking is that it can be implemented using an easy and cheap three-wire (TX/RX/Common) cable.

HARDWARE -- Also called RTS/CTS handshaking. Hardware handshaking requires extra signals be sent between the two units, thus this is more expensive to implement due to the increased numbers of wires in the interconnecting cables.

In operation, the destination end determines that it is empty, and activates its CTS (Clear To Send) signal. In response,

the source end sends data so long as the CTS signal remains active.

Many devices have the RTS/CTS signals wired directly into the hardware. Thus, an inactive CTS signals from the destination end can instantly shut down the source end. These hardware operations can be very fast because no software control is necessary in this case. Also, this manner of handshaking can be used regardless of the nature of the data being transmitted, ASCII coded or binary.

Multi-Drop Full Duplex -- In a full-duplex multi-drop situation, all available units are wired in parallel. For receiver circuitry this is no problem so long as the load on the network is not excessive. All units have their receivers enabled at all times.

Each message sent through the system is somehow identified by giving it a drop address. All units will receive all messages. All units check the drop address against their own address, and only the unit with the matching address responds.

When a unit determines that it has something to transmit it turns on its transmitter, sends the necessary data packet, and then disables its transmitter.

Full Duplex Multi-drop is usually found in multi-master or peer to peer systems, where all units have a more or less equal chance of needing to transmit a message. Often, the units needs to verify that the message they sent are sent correctly so the receiver is left on at all times.

The advantage to this system is that many units can be connected to a simple three-wire (RX/RX/Common) cable. The drawback to this system is increased firmware and software complexity.

Multi-Drop Half Duplex -- Multi-Drop Half-Duplex operation is identical to Full-Duplex except that the transmitting unit's receiver is disabled when the unit is transmitting.

All units maintain their transmitters disabled and receivers enabled at all times except when they need to transmit. Usually, protocols dictate that only the unit matching the drop address can transmit. This unit turns on its transmitter, turns off its receiver, sends the necessary data packet, and then disables its transmitter and enables its receiver.

Half Duplex Multi-drop is usually found in Master/Slave systems where one unit is designated a Master and all other units are Slaves. The Master transmits a message to one Slave, and then disable it's transmitter. All Slaves hear the message, but only the Slave with the matching "drop address" will turn on its transmitter and respond.

Using RS-485 with the ZYGGOT V5F

The ZYGGOT V5F does not provide RS-485 compatible signals. It is necessary to purchase and install a third-party RS-232 to RS-485 converter.

In this mode, transmitter control is ZYGGOT Signal CTS, available on the DB-9 connector, Pin 8. When the ZYGGOT asserts this signal, the converter enables its transmitting section.

Data Types

In ZYGGOT V5F, data may be stored or used in a variety of different formats. The format used depends on how the information is to be interpreted. Typical interpretations are binary bit patterns, unsigned numbers, signed numbers, floating point values, and strings.

Type Name Description

BOOL Boolean: A single bit. It can contain only the values '0' or '1'.

BYTE Byte: A string of 8 consecutive bits. Byte values are used where the value of the data is not as important as the bit patterns (shifts and rotates).

WORD Word A string of 16 consecutive bits. Word values are used where the value of the data is not as important as the bit patterns (shifts and rotates).

DWORD: Double Word A string of 32 consecutive bits. DWORD values are used where the value of the data is not as important as the bit patterns (shifts and rotates).

INT Integer A 16-bit signed value. Integers are used where the value of the data is expected to be in the range of -32,768 to +32,767

SINT: Short Integer An 8-bit signed value. Short Integers are used where the value of the data is expected to be in the range of -128 to +127.

DINT: Double Integer A 32-bit signed value. Double Integers are used where the value of the data is expected to be in the range of -2,147,483,648 to +2,147,483,647.

UINT: Unsigned Integer A 16-bit unsigned value. Unsigned Integers are used where the value of the data is expected to be in the range of -0 (zero) to 65,535.

USINT: Unsigned Short Integer An 8-bit unsigned value. Unsigned Short Integers are used where the value of the data is expected to be in the range of 0 (zero) to 255

UDINT: Unsigned Double Integer A 32-bit unsigned value. Unsigned Double Integers are used where the value of the data is expected to be in the range of 0 (zero) to 4,294,967,296.

REAL Floating Point: A 32-bit value. Values are stored and operated on in IEEE single precision (six digit) format. Values range from -3.40282E+38 to +3.40282E+38.

STRING: String A variable-length succession of characters. Each character is represented by one byte. The bits in word registers may be used as Boolean values. In this case, Bit Offset Addressing is used to specify the Register Type, Offset, and Bit Offset for the required bit. Using Boolean registers to represent Real numbers is usually ineffective.

STORAGE ORDER

32-bit values (DWORD, DINT, UDINT) occupy 32 consecutive bits of data, or two (2 consecutive 16-bit registers. For example, if a DINT is defined at Register %R43, the 32-bit value is contained in %R43 and %R44.

For 32-bit values, data is stored Low Order Word first. For example, if a DINT is defined at Register %R43 and contains the value "65540", (000000000000000100000000000000100) register %R43 will contain "4" and %R44 will contain "1".

Byte values (such as STRINGS) are stored High Order Byte first. For example, to store the string "31" in register %R43, store the HEX value 3133 (decimal 12595).

Register Types]

Controllers offer a wide variety of Register Types. In most cases, the controller treats register types as if they were memory locations.

The following is a list of register types implemented normally available but not all are available for the user.

%AI Analog Input

16-bit input registers used to gather analog input data such as voltages, temperatures, and speed settings coming from an attached device.

%AQ Analog Output

16-bit output registers used to send analog information such a voltages, levels or speed settings to an attached device.

%I Digital Input

Single-bit input registers. Typically, an external switch is connected to the registers.

%K Key Bit

Single-bit flags used to give the programmer direct access to any front panel keys appearing on a unit. Only the OCS series has keypads.

%Q Digital Output

Single-bit output registers. Typically, these bits are connected to an actuator, indicator light or alarm annunciator.

%R General Purpose Register

Retentive 16-bit registers.

%S System Bit

Single-bit bit coils predefined for system use.

%SR System Register

16-bit registers predefined for system use.

%T Temporary Bit

Non-retentive single-bit registers.

Bit-Mapped Addressing of 32-bit Registers

Bit-mapped addressing of 32-bit registers is not allowed. Bit offset values range from 1 to 16.

In order to access all 32 bits in a double register it is necessary to address the upper word of the register separately. Storage is such that the lower word is stored in the first (base) register, and the upper word is stored in the next consecutive register.

For example, if the 32-bit binary 00000000000000010000000000000100 value (65540 decimal) is loaded into register %R43, %R43 contains 0000000000000100 and %R44 contains 0000000000000001. Therefore, to check Bit 17 of the DWORD stored at %R43, one must check Bit 1 of %R44, addressed as %R44.1.

Numbering Base

In ZYGGOT all offsets begin with 1 (one). 0 (zero) is not valid for register offset nor bit offset addressing.

Register offsets are thus in the range of 1 to X, where X is the maximum number of register in this model. For example, if the selected type has 2048 %R registers, they are addressed as %R01 through %R2048.

Bit Offsets are in the range of 1 to 16.

Groups of Boolean registers can be accessed as a 16-bit register. In this case, though, the Bit offset must lie on a 16-bit boundary, 1, 17, 33, etc.

MODBUS

MEMORY MAP FOR SERIAL AND ETHERNET COMMUNICATION TCP/IP AND HTTP

READING STATE FLAGS (Coil M) - 1 Bit (active = 1)
Default offset = 3000
Reference - 3001
(Read Only)

%M1 Sensor Net Comm. OK
 %M2 Sensor Net Comm. Error
 %M3 Clear Data
 %M4 Restart Differential Data
 %M5 On Flash (Liga Flash)
 %M6 Reading Sensors
 %M7 Off Flash (Desliga Flash)
 %M8 Reserved
 %M9 Reserved
 %M10 Reserved
 %M11 Reserved
 %M12 Reserved
 %M13 Reserved
 %M14 Reserved
 %M15 Reserved
 %M16 Reserved
 %M17 Reserved
 %M18 Reserved
 %M19 Reserved
 %M20 Reserved
 %M21 Net Mute Command
 %M22 Net Reset Command
 %M23 Diff. Read. Temp.
 %M24 Simulating Diff.
 %M30 Modbus Error
 %M32 Modbus OK
 %M42 State Alarm Active
 %M43 State Trip Active
 %M47 State Fail Active
 %M57 Sensor Not Respondig
 %M59 Target Fail Active
 %M60 Air Fail Active
 %M63 All Sensor OK
 %M65 Target Alarm
 %M66 Target Trip
 %M67 Air Alarm
 %M68 Air Trip
 %M69 Flash On State
 %M70 Flash Off State
 %M81 DI1 Input On
 %M82 DI2 Input On
 %M83 DI3 Input On
 %M84 DI4 Input On
 %M91 Mute Input On
 %M92 Reset Input On

READING STATE FLAGS (Coil M) - 1 Bit (active = 1)
Default offset = 3000
Reference - 3001
(Read Only)

%M241 State Group 1 Target Alarm
 %M242 State Group 1 Air Alarm
 %M243 State Group 2 Target Alarm
 %M244 State Group 2 Air Alarm
 %M245 State Group 3 Target Alarm
 %M246 State Group 3 Air Alarm
 %M247 State Group 4 Target Alarm
 %M248 State Group 4 Air Alarm
 %M249 State Group 5 Target Alarm
 %M250 State Group 5 Air Alarm
 %M251 to %M254 Reserved
 %M252 Reserved
 %M253 Reserved
 %M254 Reserved
 %M255 State Ext Fail 1 Alarm
 %M256 State Ext Fail 2 Alarm
 %M257 State Sensor Not Resp Alarm
 %M258 Reserved
 %M259 State Target Alarm
 %M260 State Target Trip
 %M261 State Air Alarm
 %M262 State Air Trip
 %M263 State Differential Alarm
 %M264 State Differential Trip
 %M265 State G1 Target Trip
 %M266 State G1 Air Trip
 %M267 State G2 Target Trip
 %M268 State G2 Air Trip
 %M269 State G3 Target Trip
 %M270 State G3 Air Trip
 %M271 State G4 Target Trip
 %M272 State G4 Air Trip
 %M273 State G5 Target Trip
 %M274 State G5 Air Trip
 %M275 Reserved
 %M276 Reserved
 %M277 Reserved
 %M278 State Analog 1 Alarm
 %M279 State Analog 1 Trip
 %M280 State Analog 2 Alarm
 %M281 State Analog 2 Trip
 %M282 State Analog 3 Alarm
 %M283 State Analog 3 Trip
 %M284 State Analog 4 Alarm
 %M285 State Analog 4 Trip
 %M286 to %M293 Reserved
 %M294 State System Operat. Hour
 %M295 Modbus Error Alarm
 %M296 Sensor Communication Fail
 %M297 Auto Save Target Fail
 %M298 Auto Save Air Fail
 %M299 Memory Card Error
 %M300 Reserved

READ/WRITE OF STATE FLAGS (Coil M) - 1 Bit (active = 1)
Default offset = 3000
Reference - 3001
(Read / Write)

%M101 Plot 1 Restart
 %M102 Plot 2 Restart
 %M103 Plot 3 Restart
 %M104 Plot 4 Restart
 %M105 Plot 5 Restart
 %M106 Plot 6 Restart
 %M107 Plot 7 Restart
 %M108 Plot 8 Restart
 %M109 Plot 9 Restart
 %M110 Plot 10 Restart
 %M111 Plot 11 Restart
 %M112 Plot 12 Restart
 %M113 Plot 13 Restart
 %M114 Plot 14 Restart
 %M115 Plot 15 Restart
 %M116 Plot 16 Restart

Data type MODBUS	Size
Coil	1 bit
Holding Register	16 bits

Data type MODBUS	Function	Code
Coil	Read	0x01
	Write	0x05
Holding Register	Write	0x03
	Write	0x06

MODBUS

MEMORY MAP FOR SERIAL AND ETHERNET COMMUNICATION TCP/IP AND HTTP

**READING STATE FLAGS
(Coil M) - 1 Bit (active = 1)
Default offset = 3000
Reference - 3001
(Read Only)**

%M301 Fail Active Operating Hour
%M302 Fail Active Sensor Comm.
%M303 Fail Active Not Responding
%M304 Reserved
%M305 Reserved
%M306 Fail Active Target Alarm
%M307 Fail Active Target Trip
%M308 Fail Active Air Alarm
%M309 Fail Active Air Trip
%M310 Fail Active Differ. Alarm
%M311 Fail Active Analog 1 Alarm
%M312 Fail Active Analog 2 Alarm
%M313 Fail Active Analog 3 Alarm
%M314 Fail Active Analog 4 Alarm
%M315 Fail Active Analog 1 Trip
%M316 Fail Active Analog 2 Trip
%M317 Fail Active Analog 3 Trip
%M318 Fail Active Analog 4 Trip
%M319 Fail Active Ext Fail 1
%M320 Fail Active Ext Fail 2
%M321 Fail Active Differ. Trip
%M331 Fail Active G1 Air Alarm
%M332 Fail Active G2 Air Alarm
%M333 Fail Active G3 Air Alarm
%M334 Fail Active G4 Air Alarm
%M335 Fail Active G5 Air Alarm
%M336 Fail Active G1 Air Trip
%M337 Fail Active G2 Air Trip
%M338 Fail Active G3 Air Trip
%M339 Fail Active G4 Air Trip
%M340 Fail Active G5 Air Trip
%M341 Fail Active G1 Target Alarm
%M342 Fail Active G2 Target Alarm
%M343 Fail Active G3 Target Alarm
%M344 Fail Active G4 Target Alarm
%M345 Fail Active G5 Target Alarm
%M346 Fail Active G1 Target Trip
%M347 Fail Active G2 Target Trip
%M348 Fail Active G3 Target Trip
%M349 Fail Active G4 Target Trip
%M350 Fail Active G5 Target Trip

**DATA READINGS (Register R)
(Integers 16 Bits).
Default offset = 3000
Reference = 43001
(Read Only)**

%R2001 Sensor 1 Target Temper.
to
%R2125 Sensor 125 Target Temper.

%R2126 Sensor 1 Air Temper.
to
%R2250 Sensor 125 Air Temper.

**LEITURAS FLAGS DE ESTADO
(Coil M) - 1 Bit (ativo = 1)
Ofsett Padrão = 3000
Reference - 3001
(Read Only)**

%M401 Sensor Comm. OK
%M402 Sensor Comm. Error
%M403 Sensor Net Timeout
%M404 Sensor Net Frame Parity
%M405 Sensor Net CRC Check
%M406 Sensor Net Unespect. Resp.
%M407 Sensor Net Reject Comm.
%M408 Sensor Net Reject Data
%M409 Alarm Not Acknowledged
%M410 Alarm Not Cleared
%M411 Differential Function On
%M412 Differential Warm OK
%M413 Differential First Read Done
%M414 Differential Read Valid
%M415 Reserved
%M416 Reserved
%M417 Reserved
%M418 Reserved
%M419 Reserved
%M420 Reserved
%M421 Digital Input 1 On
%M422 Digital Input 2 On
%M423 Digital Input 3 On
%M424 Digital Input 4 On
%M425 EB1: Digital Input 1
%M426 EB2: Digital Input 2
%M427 EB3: Digital Input 3
%M428 EB4: Digital Input 4
%M429 EB5: Digital Input 5
%M431 EB6: Digital Input 6
%M431 EB7: Digital Input 7
%M432 EB8: Digital Input 8
%M433 to %M440 Reserved
%M441 Digital Output 1 MUTE
%M442 Digital Output 2 RESET
%M443 Digital Output 3 D.O.3
%M444 Digital Output 4 D.O.4
%M445 EB1: AUX 1
%M446 EB2: AUX 2
%M447 EB3: AUX 3
%M448 EB4: AUX 4
%M449 EB5: AUX 5
%M450 EB6: AUX 6
%M451 EB7: AUX 7
%M452 EB8: AUX 8
%M453 to %M 460 Reserved

**READING STATE FLAGS
(Coil M) - 1 Bit (active = 1)
Default offset = 3000
Reference - 3001
(Read Only)**

%M501 Sensor 001 Not Responding
to
%M625 Sensor 125 Not Responding

**STATE FLAGS (R) - 1 Bit
(Not mappable in normal protocol).
Note: Read 16 Bit Registry Normally.
Default offset = 3000
Reference = 43001
and test Bit 2 value.
(Read Only)**

%R5001.2 Target Alarm Sensor 1
to
%R5125.2 Target Alarm Sensor 125

%R6001.2 Target Trip Sensor 1
to
%R6125.2 Target Trip Sensor 125

%R7001.2 Air Alarm Sensor 1
to
%R7125.2 Air Alarm Sensor 125

%R8001.2 Air Trip Sensor 1
to
%R8125.2 Air Trip Sensor 125

**DATA READINGS (Register R)
Default offset = 3000
Reference = 43001
(Read Only)**

%R981 H. On at Diff Start (32 Bit)
%R987 M. On at Diff Start (16 Bit)
%R985 Total Diff Time Hour (32 Bit)
%R988 Total Diff Time Min. (16 Bit)
%R1915 Time to Warm Hour (16 Bit)
%R1913 Time to Warm Min. (16 Bit)
%R1007 Time to Restart H. (16 Bit)
%R1003 Time to Restart M. (16 Bit)
%R1081 > Target Temper. (16 Bit)
%R1082 > Air Temperat. (16 Bit)
%R1330 N. Sensors Resp. (16 Bit)
%R1333 N. Sens. Not Resp (16 Bit)
%R1079 Total Alarms (16 Bits)
%R1083 Total Trips (16 Bits)
%R3051 Analog 1 Value (16 Bit)
%R3053 Analog 2 Value (16 Bit)
%R3053 Analog 3 Value (16 Bit)
%R3054 Analog 4 Value (16 Bit)
%R1192 =1 // Unity = % (16 Bit)
%R1192 =2 // Unity = °C (16 Bit)
%R1192 =4 // Unity =°F (16 Bit)

MODBUS

MEMORY MAP FOR SERIAL AND ETHERNET COMMUNICATION TCP/IP AND HTTP

PARAMETERS (Register R)
Menu: RELAY CONFIG
Default offset = 3000
Reference = 43001
(Read / Write)

%R801 Language
 (0=English/1=Português/2=Espanhol)
 %R879 Screen Brightness (50-100%)
 %R790.2 Save Screen (0=No/1=Yes)
 %R860 Save Screen Time (5-200 min)
 %R881 Saving Brightness (5-50%)
 %R760 - %R764 Plant (10 Bytes ASCII)
 %R770 - %R774 Location (10 Bytes ASCII)
 %R780 - %R784 Panel (10 Bytes ASCII)
 %R809 Memory Card Error Action
 (0=None/1=Log)

PARAMETROS (Register R)
Menu: PARAMETERS CONFIG
Ofsett Padrão = 3000
Reference = 43001
(Read / Write)

%R790.1 Centigrades / Fahrenheit (0/1)
 %R802 Reset On Fail Unaknowledged
 (0=No/1=Yes)
 %R840 Reset On Fail Active (0=No/1=Yes)
 %R803 Wait If Flash = On (0=No/1=Yes)
 %R896 Clear Indication (0= Auto/1= AfterReset)
 %R804 Air Alarme Level (0-999)
 %R805 Air Trip Level (0-999)
 %R806 Call Screen On Fail (0=No/1=Yes)
 %R807 Call Screen On Alarm (0=No/1=Yes)
 %R1010.1 Reserved
 %R1010.2 Reserved
 %R808 Return to Main Time (0=no/0-3600 s)

PARAMETERS (Register R)
Menu: SENSORS
Default offset = 3000
Reference = 43001
(Read / Write)

%R810 Total Sensor Number (3-125)
 %R891 Auto Save Target Data (0/1)
 %R892 Auto Save Air Data (0/1)
 %R850 Save Methode (0=Always to the Same
 File/1=New File Each Start)
 %R859 Save Period (10-1440 m)
 %R839 Start New File (0=No/1=Yes)
 %R849 Read Write Fail Action (0=None/1=Log)

PARAMETERS (Register R)
Menu: ANALOG INPUTS
Default offset = 3000
Reference = 43001
(Read / Write)

%R751 - %R753 Ai1 Name (6 Bytes ASCII)
 %R754 - %R756 Ai2 Name (6 Bytes ASCII)
 %R757 - %R759 Ai3 Name (6 Bytes ASCII)
 %R787 - %R790 Ai4 Name (6 Bytes ASCII)
 %R831 Read Mode (0=%/1=Temp)
 %R832 Scale (10 - 99999)

PARAMETROS (Register R)
Menu: BLOCK PROGRAMING
Default offset = 3000
Reference = 43001
(Read / Write)

%R811 Block 1 Start (1-125)
 %R812 Block 1 End (1-125)
 %R821 Block 1 Target Alarm (0-999)
 %R821 Block 1Target Trip (0-999)

 %R813 Block 2 Start (1-125)
 %R814 Block 2 End (1-125)
 %R823 Block 2 Target Alarm (0-999)
 %R824 Block 2Target Trip (0-999)

 %R815 Block 3 Start (1-125)
 %R816 Block 3 End (1-125)
 %R825 Block 3 Target Alarm (0-999)
 %R826 Block 3Target Trip (0-999)

 %R817 Block 4 Start (1-125)
 %R818 Block 4 End (1-125)
 %R827 Block 4 Target Alarm (0-999)
 %R828 Block 4Target Trip (0-999)

 %R819 Block 5 Start (1-125)
 %R820 Block 6 End (1-125)
 %R829 Block 7 Target Alarm (0-999)
 %R830 Block 8Target Trip (0-999)

PARAMETERS (Register R)
Menu: MODBUS CONFIG
Default offset = 3000
Reference = 43001
(Read / Write)

%R841 Baud Rate (1=
 9600/2=19200/4=38400)
 %R842 Address (1-247)
 %R843 Parity (1=None/2=Odd/4=Even)
 %R844 Handshake
 (1=None/2=XON/XOF/4=CTS/RTS/8=MD/Half)
 %R845 Timeout (0-1023 s)
 %R846 Stop Bits (1=1/2=2)
 %R847 Port Mode (1=RS232)
 %R848 Modbus (0=Inactive/1=Active)

PARAMETERS (Register R)
Menu: TRENDING CONFIG
Default offset = 3000
Reference = 43001
(Read / Write)

%R835 Scale (0-9999)
 %R836 Index Mode (0=Display/1=Menu)
 %R837 HMI Reset (0=Disable/1=Enable)
 %R838.1 Enable Retentive (0=No/1=Yes)
 %R851 Index 3A-7A (1-125)
 %R852 Index 3B-7B (1-125)
 %R853 Index 3C-7C (1-125)
 %R854 Index 8A-12A (1-125)
 %R855 Index 8B-12B (1-125)
 %R856 Index 8C-12C (1-125)

MEMORY MAP FOR SERIAL AND ETHERNET COMMUNICATION TCP/IP AND HTTP

PARAMETROS (Register R)
Menu: PROTECTIONS
Ofsett Padrão = 3000
Reference = 43001
(Read / Write)

Opções p/ Alarm Action: (0=None / 1=Log / 2=Alarm)
Opções para Trip Action: (0=None / 1=Log / 4=Trip)
Opções p/ D. Output: (0=None / 1=D.O.3 / 2=D.O.4 / 4=Aux1 / 8=Aux2 / 16=Aux3 / 32=Aux4 / 64=Aux5 / 128=Aux6 / 256=Aux7 / 512=Aux8)

%R862 Note Respond Action
 %R863 Note Resp. D. Output
 %R864 Target Alarm Action
 %R865 Target Alarm D. Output
 %R868 Note Respond Action
 %R869 Note Resp. D. Output
 %R866 Air Alarm Action
 %R867 Air Alarm D. Output
 %R870 Air Trip Action
 %R871 Air Trip D. Output
 %R877 Sensor Comm. Fail Action
 %R878 Sensor Comm Fail D. Output
 %R857 Modbus Comm. Fail Action
 %R858 Modbus Comm. Fail Aux Output

%R1020 Differential - Execute Diff (0=Non/1=Yes)
 %873 Differential Alarm Level (0-200%)
 %874 Differential Trip Level (0-200%)
 %R1016 Differential Alarm Action
 %R1017 Differential Trip Action
 %R875 Differential Warmup Hours (0-50 h)
 %R1018 Differential Restart Period (0-10000 h) (0=No)
 %R876 Differential D. Output

%R880 Operating Time Action
 %R893 Operating Time Level (0- 250000 h)

PARAMETERS (Register R)
Menu: TARGET ALARM LEVELS
Default offset = 3000
Reference = 43001
(Read / Write)

%R501 Sensor 1 Target Alarm Level (0-999)
 %R502 Sensor 2 Target Alarm Level (0-999)
 ===
 %R625 Sensor 125 Target Alarm Level (0-999)

PARAMETERS (Register R)
Menu: TARGET TRIP LEVELS
Default offset = 3000
Reference = 43001
(Read / Write)

%R626 Sensor 1 Target Trip Level (0-999)
 %R627 Sensor 2 Target Trip Level (0-999)
 ===
 %R750 Sensor 125 Target Trip Level (0-999)

PARAMETROS (Register R)
Menu: PROTECTIONS GROUP
Ofsett Padrão = 3000
Reference = 43001
(Read / Write)

Opções p/ Alarm Action: (0=None / 1=Log / 2=Alarm)
Opções para Trip Action: (0=None / 1=Log / 4=Trip)
Opções p/ Aux Output: (0=None / 1=D.O.3 / 2=D.O.4 / 4=Aux1 / 8=Aux2 / 16=Aux3 / 32=Aux4 / 64=Aux5 / 128=Aux6 / 256=Aux7 / 512=Aux8)

%R901 Group 1 Target Alarm Action
 %R906 Group 1 Target Trip Action
 %R911 Group 1 Air Alarm Action
 %R916 Group 1 Air Trip Action
 %R921 Group 1 Target Alarm D. Output
 %R926 Group 1 Target Trip D. Output
 %R931 Group 1 Air Alarm D. Output
 %R936 Group 1 Air Trip D. Output

%R902 Group 2 Target Alarm Action
 %R907 Group 2 Target Trip Action
 %R912 Group 2 Air Alarm Action
 %R917 Group 2 Air Trip Action
 %R922 Group 2 Target Alarm D. Output
 %R927 Group 2 Target Trip D. Output
 %R932 Group 2 Air Alarm D. Output
 %R937 Group 2 Air Trip D. Output

%R903 Group 3 Target Alarm Action
 %R908 Group 3 Target Trip Action
 %R913 Group 3 Air Alarm Action
 %R918 Group 3 Air Trip Action
 %R923 Group 3 Target Alarm D. Output
 %R928 Group 3 Target Trip D. Output
 %R933 Group 3 Air Alarm D. Output
 %R938 Group 3 Air Trip D. Output

%R904 Group 4 Target Alarm Action
 %R909 Group 4 Target Trip Action
 %R914 Group 4 Air Alarm Action
 %R919 Group 4 Air Trip Action
 %R924 Group 4 Target Alarm D. Output
 %R929 Group 4 Target Trip D. Output
 %R934 Group 4 Air Alarm D. Output
 %R939 Group 4 Air Trip D. Output

%R905 Group 5 Target Alarm Action
 %R910 Group 5 Target Trip Action
 %R915 Group 5 Air Alarm Action
 %R920 Group 5 Air Trip Action
 %R925 Group 5 Target Alarm D. Output
 %R930 Group 5 Target Trip D. Output
 %R935 Group 5 Air Alarm D. Output
 %R940 Group 5 Air Trip D. Output

PARAMETROS (Register R)
Menu: PROTECTIONS ANALOG
Ofsett Padrão = 3000
Reference = 43001
(Read / Write)

Opções p/ Alarm Action: (0=None / 1=Log / 2=Alarm)
Opções para Trip Action: (0=None / 1=Log / 4=Trip)
Opções p/ Aux Output: (0=None / 1=D.O.3 / 2=D.O.4 / 4=Aux1 / 8=Aux2 / 16=Aux3 / 32=Aux4 / 64=Aux5 / 128=Aux6 / 256=Aux7 / 512=Aux8)

%R961 Analog 1 Alarm Action
 %R883 Analog 1 Alarm Level High (0-100 %)
 %R969 Analog 1 Alarm D. Output
 %R965 Analog 1 Trip Action
 %R887 Analog 1 Trip Level High (0-100 %)
 %R973 Analog 1 Trip D. Output

%R962 Analog 2 Alarm Action
 %R884 Analog 2 Alarm Level High (0-100 %)
 %R970 Analog 2 Alarm D. Output
 %R966 Analog 2 Trip Action
 %R888 Analog 2 Trip Level High (0-100 %)
 %R974 Analog 2 Trip D. Output

%R963 Analog 3 Alarm Action
 %R854 Analog 3 Alarm Level High (0-100 %)
 %R971 Analog 3 Alarm D. Output
 %R967 Analog 3 Trip Action
 %R889 Analog 3 Trip Level High (0-100 %)
 %R975 Analog 3 Trip D. Output

%R964 Analog 4 Alarm Action
 %R855 Analog 4 Alarm Level High (0-100 %)
 %R972 Analog 4 Alarm D. Output
 %R968 Analog 4 Trip Action
 %R890 Analog 4 Trip Level High (0-100 %)
 %R976 Analog 4 Trip D. Output

PARAMETROS (Register R)
Menu: PROTECTIONS EXTERNAL FAIL
Ofsett Padrão = 3000
Reference = 43001
(Read / Write)

Opções para Alarm Action (0=None/1=Log/2=Alarm)
Opções para Trip Action (0=None/1=Log/4=Trip)
Opções p/ D. Output (0=None / 1=D.O.3 / 2=D.O.4 / 4=Aux1 / 8=Aux2 / 16=Aux3 / 32=Aux4 / 64=Aux5 / 128=Aux6 / 256=Aux7 / 512=Aux8)

%R977 External Fail 1 Action
 %R983 External Fail 1 Trip Delay (0-999 x 0,1 s)
 %R979 External Fail D. Output
 %R767 - %R769 External Fail Assign Name (6 Bytes ASCII)

%R978 External Fail 1 Action
 %R984 External Fail 1 Trip Delay (0-999 x 0,1 s)
 %R980 External Fail D. Output
 %R777 - %R779 External Fail Assign Name (6 Bytes ASCII)

GENERAL SPECIFICATIONS

OVERVIEW

- The protocol is standard Modbus RTU over RS-485.
- Sensor must be configured by an USB cable prior to communication.
- Every sensor must have a unique address in the network.
- Address 0 (zero) is reserved to broadcast messages to all sensors.
- Registers are signed integers with 16 bits precision.
- Registers have more than one address and can be accessed in more than one way in order to facilitate its utilization.
- The Target temperature are always corrected by emissivity value.

SERIAL CONFIGURATION

Baud rate: 1200; 2400; 4800; 9600; 19200; 38400; 57600; 115200

Data bits: 8

Parity: No; Even; Odd

Stop bits: 0.5; 1; 1.5; 2

ADDRESS TABLE

Coil (Modbus function 01)

Address	Name	Description
27 (0x001B)	Blink	Blink control: 0-off 1-on
2560 (0x0A00)	Term_Res	RS-485 Termination Res. Control: 0-off 1-on

HOLDING REGISTER

(Modbus function 03)

Address	Name	Description
27 (0x001B)	Blink	Blink control: 0-off 1-on
2560 (0x0A00)	Term_Res	RS-485 Termination Resistor control: 0-off 1-on
256 (0x0100)	Emissivity	Emissivity multiplier divided by 100: 0 to 200 (default 95 -> read value = measure / 0.95)
21 (0x0015)	User_1	Retentive free use 1
22 (0x0016)	User_2	Retentive free use 2
23 (0x0017)	User_3	Retentive free use 3
24 (0x0018)	User_4	Retentive free use 4

INPUT REGISTER

(Modbus function 04)

Address	Name	Description
1 (0x0001)		
30001 (0x7531)	Version	Sensor version (0x0102 = 1.02)
2 (0x0002)		
30002 (0x7532)	Column_and_Sensor	Sensor column and number (auxiliary)
3 (0x0003)		
30003 (0x7533)	Status	Bit[15-3]: Reserved Bit[2]: Blink(0-off 1-on) Bit[1]: Termination Resistor (0-off 1-on) Bit[0]: Check (1-OK)
4 (0x0004)		
30004 (0x7534)	Target_C_10	Target temperature in Celsius multiplied by 10 (367 = 36.7°C)
5 (0x0005)		
30005 (0x7535)	Environment_C_10	Environment temperature in Celsius multiplied by 10 (253 = 25.3°C)
6 (0x0006)		
30006 (0x7536)	Target_F_10	Target temperature in Fahrenheit multiplied by 10 (982 = 98.2°C)
7 (0x0007)		
30007 (0x7537)	Environment_F_10	Environment temperature in Fahrenheit multiplied by 10 (775 = 77.5°C)
8 (0x0008)		
30008 (0x7538)	Target_C	Target temperature in Celsius (36 = 36°C)
9 (0x0009)		
30009 (0x7539)	Environment_C	Environment temperature in Celsius (25 = 25°C)
10 (0x000A)		
30010 (0x753A)	Target_F	Target temperature in Fahrenheit (98 = 98°C)
11 (0x000B)		
30011 (0x753B)	Environment_F	Environment temperature in Fahrenheit (77 = 77°C)
12 (0x000C)		
30012 (0x753C)	V_Bus_100	Bus Tension in Volts multiplied by 100 (2341 = 23.41V)

MODBUS OVER ETHERNET TCP IP SERVER

GENERAL SPECIFICATIONS (PART 1 / 4)

MODBUS OVER ETHERNET ETHERNET IP SERVER COMMUNICATION WILL WORK WITH PLCs AND ALLEN BRADLEY PROTOCOL OR ALLEN BRADLEY LIKE

Maximum connection = 2 /// PORT = 44818 TCP or 2222 UDP

SEND (PRODUCED) FIRST REGISTER = %R2801 /// LAST REGISTER = %R2928 /// WORDS COUNT = 128

RECEIVE (CONSUMED) FIRST REGISTER = %R3201 /// LAST REGISTER = %R3328 /// WORDS COUNT = 128

The Status word provides Ethernet/IP connection status. The upper byte of the word

contains the Class 3 (Explicit) connection count and the lower byte contains the Class 1 (IO) connection count.

NOTE: When the Status word indicates no connections, the Consumed OCS registers contain old data

As up to 128 words are allowed in each communication, a pagination scheme is used to access all important and available data.

In this version, parameter programming via the Ethernet connection is not allowed, so the variable on the corresponding screen is permanently set to "Disabled"

However, it is allowed to send some commands via the Ethernet connection, in addition to specifying the page to be read.

IN THE PLC CONNECTION PARAMETER, USE "100" FOR THE ASSEMBLY INSTANCE INPUT WITH SIZE = 128 AND USE "101" FOR THE ASSEMBLY INSTANCE OUTPUT WITH SIZE = 128

CONSUMED	Controller Tags	WRITE PAGE	RESERVED	FUNCTION	DATA	NOTE	WARNING
%R3201 - %3300		XXX					
%R3301	O.Data[100]	0	MUTE	1= MUTE // 0 = DO NOTHING		SEND COMMAND MUTE TO RELAY	
%R3302	O.Data[101]	0	RESET	1= RESET // 0 = DO NOTHING		SEND COMMAND RESET TO RELAY	
%R3303	O.Data[102]	0	SAVE TARGET	1= SAVE // 0 = DO NOTHING		SAVE TARGET DATA TO MEMORY CARD	
%R3304	O.Data[103]	0	SAVE AIR	1= SAVE // 0 = DO NOTHING		SAVE AIR DATA TO MEMORY CARD	
%R3305		0	RESERVED				
%R3306		0	RESERVED				
%R3307		0	RESERVED				
%R3308		0	RESERVED				
%R3309		0	RESET DIFFERENTIAL WARM	1= RESET DIFFERENTIAL // 0 = DO NOTHING		RESET DIFFERENTIAL WITH A NEW WARM PERIOD	CAUTION
%R3310	O.Data[104]	0	RESET DIFFERENTIAL NO WARM	1= RESET DIFFERENTIAL // 0 = DO NOTHING		RESET DIFFERENTIAL WITHOUT A NEW WARM PERIOD	CAUTION
%R3311	O.Data[105]	0	RESERVED				
%R3312		0	RESERVED				
%R3313		0	RESERVED				
%R3314		0	RESERVED				
%R3315		0	RESERVED				
%R3316		0	RESERVED				
%R3317		0	RESERVED				
%R3318		0	RESERVED				
%R3319		0	RESERVED				
%R3320		0	RESERVED				
%R3321		0	RESERVED				
%R3322		0	RESERVED				
%R3323		0	RESERVED				
%R3324		0	RESERVED				
%R3325		0	RESERVED				
%R3326	O.Data[106]	0	PAGE TO WRITE	NOTE USED IS THIS VERSION		0 = DO NOTHING // 1 TO 15 SET PAGE TO BE READ	
%R3327	O.Data[107]	0	PAGE TO READ	SET PAGE FROM 0 TO 15 TO BE READ FROM RELAY		NOTE USED IN THIS VERSION	
%R3328	O.Data[108]	0	WRITING DATA VALID	1= DATA TO BE WRITE = VALID // 0 = DO NOTHING			

MODBUS OVER ETHERNET TCP IP SERVER

GENERAL SPECIFICATIONS (PART 2 / 4)

PRODUCED	Controller Tags	READ PAGE	FUNCTION	DATA	NOTE	WARNING
%R2927	I.Data[126]	0 - 16	PAGE READED	0 - 16	0 = READED NONE // 1 TO 15 DATA WILL BE READED	
%R2928	I.Data[127]	0 - 16	DATA READED VALID	1 = DATA VALID // 0 = WAIT NEW DATA	CONSIDER THE DATA READED ONLY IF %R2928 = 1	
%R2801 - %R2900		1 TO 16	DATA PAGES	SEE BELOW		
%R2801 - %R2925	I.Data[0] - I.Data[125]	1	TARGET TEMPERATURES 1 TO 125	x 10 - AS READED (FORMAT XXX.X)	THE DATA NEED TO BE DIVIDED BY 10 TO INSERT THE COMA	
%R2801 - %R2925	I.Data[0] - I.Data[125]	2	AIR TEMPERATURES 1 TO 125	x 10 - AS READED (FORMAT XXX.X)	THE DATA NEED TO BE DIVIDED BY 10 TO INSERT THE COMA	
%R2801 - %R2925	I.Data[0] - I.Data[125]	3	TARGET ALARM LEVELS 1 TO 125	x 10 - AS READED (FORMAT XXX.X)	THE DATA NEED TO BE DIVIDED BY 10 TO INSERT THE COMA	
%R2801 - %R2925	I.Data[0] - I.Data[125]	4	TARGET TRIP LEVELS 1 TO 125	x 10 - AS READED (FORMAT XXX.X)	THE DATA NEED TO BE DIVIDED BY 10 TO INSERT THE COMA	
%R2801 - %R2925	I.Data[0] - I.Data[125]	5	THM SENSORS VOLTAGE	X100 - AS READED (FORMAT XX.XX)	THE DATA NEED TO BE DIVIDED BY 100 TO INSERT THE COMA	
%R2801 - %R2925	I.Data[0] - I.Data[125]	6	RESERVED	X100 - AS READED (FORMAT XX.XX)		
%R2801 - %R2925	I.Data[0] - I.Data[125]	7	TARGET ALARM ACTIVE 1 TO 125	146 = ACTIVE // 0 = INACTIVE		
%R2801 - %R2925	I.Data[0] - I.Data[125]	8	TARGET TRIP ACTIVE 1 TO 125	162 = ACTIVE // 0 = INACTIVE		
%R2801 - %R2925	I.Data[0] - I.Data[125]	9	AIR ALARM ACTIVE 1 TO 125	146 = ACTIVE // 0 = INACTIVE		
%R2801 - %R2925	I.Data[0] - I.Data[125]	10	AIR TRIP ACTIVE 1 TO 125	162 = ACTIVE // 0 = INACTIVE		
%R2801 - %R2925		11	RESERVED			
%R2801 - %R2925		12	RESERVED			
%R2801 - %R2925		13	RESERVED			
%R2801 - %R2925		14	REERVED			
%R2801	I.Data[0]	15	THM COMM OK	0 = NOT OK // 1 = OK		
%R2802	I.Data[1]	15	THM COMM NOT OK	0 = OK // 1 = NOT OK		
%R2803	I.Data[2]	15	RESERVED			
%R2804	I.Data[3]	15	RESERVED			
%R2805	I.Data[4]	15	RESERVED			
%R2806	I.Data[5]	15	RESERVED			
%R2807	I.Data[6]	15	RESERVED			
%R2808	I.Data[7]	15	RESERVED			
%R2809	I.Data[8]	15	RESERVED			
%R2810	I.Data[9]	15	RESERVED			
%R2811	I.Data[10]	15	RESERVED			
%R2812	I.Data[11]	15	ETHERNET NOT LINKED	0 = ETHERNET LINKED // 1 = NOT LINKED		
%R2813	I.Data[12]	15	ANY FAIL ACTIVE	0 = NO // FAIL ACTIVE = 1		
%R2814	I.Data[13]	15	TARGET FAIL	0 = NO // FAIL ACTIVE = 1		
%R2815	I.Data[14]	15	AIR FAIL	0 = NO // FAIL ACTIVE = 1		
%R2816	I.Data[15]	15	ALARM ACTIVE	0 = NO // ALARM ACTIVE = 1		
%R2817	I.Data[16]	15	TRIP ACTIVE	0 = NO // TRIP ACTIVE = 1		
%R2818	I.Data[17]	15	ALARM UNACKNOWLEDGED	0 = NO // 1 = YES		
%R2819	I.Data[18]	15	ALARM UNCLEARD	0 = NO // 1 = YES		
%R2820	I.Data[19]	15	TARGET FAIL ACTIVE	0 = NO // 1 = YES		
%R2821	I.Data[20]	15	TARGET TRIP ACTIVE	0 = NO // 1 = YES		
%R2822	I.Data[21]	15	AIR ALARM ACTIVE	0 = NO // 1 = YES		
%R2823	I.Data[22]	15	AIR TRIP ACTIVE	0 = NO // 1 = YES		

MODBUS OVER ETHERNET TCP IP SERVER

GENERAL SPECIFICATIONS (PART 3 / 4)

PRODUCED	Controller Tags	READ PAGE	FUNCTION	DATA	NOTE	WARNING
%R2824	i.Data[23]	15	EXTERNAL FAIL 1 ACTIVE	0 = NO // 1 = YES		
%R2825	i.Data[24]	15	EXTERNAL FAIL 2 ACTIVE	0 = NO // 1 = YES		
%R2826	i.Data[25]	15	ANALOG 1 ALARM ACTIVE	0 = NO // 1 = YES		
%R2827	i.Data[26]	15	ANALOG 2 ALARM ACTIVE	0 = NO // 1 = YES		
%R2828	i.Data[27]	15	ANALOG 3 ALARM ACTIVE	0 = NO // 1 = YES		
%R2829	i.Data[28]	15	ANALOG 4 ALARM ACTIVE	0 = NO // 1 = YES		
%R2830	i.Data[29]	15	ANALOG 1 TRIP ACTIVE	0 = NO // 1 = YES		
%R2831	i.Data[30]	15	ANALOG 2 TRIP ACTIVE	0 = NO // 1 = YES		
%R2832	i.Data[31]	15	ANALOG 3 TRIP ACTIVE	0 = NO // 1 = YES		
%R2833	i.Data[32]	15	ANALOG 4 TRIP ACTIVE	0 = NO // 1 = YES		
%R2834	i.Data[33]	15	EXCESS LIFE ACTIVE	0 = NO // 1 = YES		
%R2835	i.Data[34]	15	DIFFERENTIAL ALARM ACTIVE	0 = NO // 1 = YES		
%R2836	i.Data[35]	15	DIFFERENTIAL TRIP ACTIVE	0 = NO // 1 = YES		
%R2837	i.Data[36]	15	RESERVED			
%R2838	i.Data[37]	15	RESERVED			
%R2839	i.Data[38]	15	G1 TARGET ALARM ACTIVE	0 = NO // 1 = YES		
%R2840	i.Data[39]	15	G2 TARGET ALARM ACTIVE	0 = NO // 1 = YES		
%R2841	i.Data[40]	15	G3 TARGET ALARM ACTIVE	0 = NO // 1 = YES		
%R2842	i.Data[41]	15	G4 TARGET ALARM ACTIVE	0 = NO // 1 = YES		
%R2843	i.Data[42]	15	G5 TARGET ALARM ACTIVE	0 = NO // 1 = YES		
%R2844	i.Data[43]	15	G1 AIR ALARM ACTIVE	0 = NO // 1 = YES		
%R2845	i.Data[44]	15	G2 AIR ALARM ACTIVE	0 = NO // 1 = YES		
%R2846	i.Data[45]	15	G3 AIR ALARM ACTIVE	0 = NO // 1 = YES		
%R2847	i.Data[46]	15	G4 AIR ALARM ACTIVE	0 = NO // 1 = YES		
%R2848	i.Data[47]	15	G5 AIR ALARM ACTIVE	0 = NO // 1 = YES		
%R2849	i.Data[48]	15	G1 TARGET TRIP ACTIVE	0 = NO // 1 = YES		
%R2850	i.Data[49]	15	G2 TARGET TRIP ACTIVE	0 = NO // 1 = YES		
%R2851	i.Data[50]	15	G3 TARGET TRIP ACTIVE	0 = NO // 1 = YES		
%R2852	i.Data[51]	15	G4 TARGET TRIP ACTIVE	0 = NO // 1 = YES		
%R2853	i.Data[52]	15	G5 TARGET TRIP ACTIVE	0 = NO // 1 = YES		
%R2854	i.Data[53]	15	G1 AIR TRIP ACTIVE	0 = NO // 1 = YES		
%R2855	i.Data[54]	15	G2 AIR TRIP ACTIVE	0 = NO // 1 = YES		
%R2856	i.Data[55]	15	G3 AIR TRIP ACTIVE	0 = NO // 1 = YES		
%R2857	i.Data[56]	15	G4 AIR TRIP ACTIVE	0 = NO // 1 = YES		
%R2858	i.Data[57]	15	G5 AIR TRIP ACTIVE	0 = NO // 1 = YES		
%R2859	i.Data[58]	15	REERVED			
%R2860	i.Data[59]	15	REERVED			
%R2861	i.Data[60]	15	REERVED			
%R2862	i.Data[61]	15	REERVED			
%R2863	i.Data[62]	15	REERVED			
%R2864	i.Data[63]	15	REERVED			

MODBUS OVER ETHERNET TCP IP SERVER

GENERAL SPECIFICATIONS (PART 4 / 4)

PRODUCED	Controller Tags	READ PAGE	FUNCTION	DATA	NOTE	WARNING
%R2865	.i.Data[64]	15	SCREEN ALARM UNCLEARED	0 = NO // 1 = YES		
%R2866	.i.Data[65]	15	SCREEN ALARM UNACKNOWLEDGED	0 = NO // 1 = YES		
%R2867	.i.Data[66]	15	SCREEN ALARM ANY FAIL ACTIVE	0 = NO // 1 = YES		
%R2868	.i.Data[67]	15	RESERVED			
%R2869	.i.Data[68]	15	RESERVED			
%R2801	.i.Data[0]	16	MAX TARGET TEMPERATURE	x 10 - AS READED (FORMAT XXX.X)	THE DATA NEED TO BE DIVIDED BY 10 TO INSERT THE COMA	
%R2802	.i.Data[1]	16	MAX AIR TEMPERATURE	x 10 - AS READED (FORMAT XXX.X)	THE DATA NEED TO BE DIVIDED BY 10 TO INSERT THE COMA	
%R2803	.i.Data[2]	16	MEMORY CARD STATUS	0=OK// 1= UNKNOWN FORMAT// 2=NO CARD// AS READED	3= NOT SUPPORTED//4=ILEGAL SWAP//5=UNKNOWN//PROTECTED	
%R2804	.i.Data[3]	16	DIFFERENTIAL TIME TO WARM HOUR	AS READED		
%R2805	.i.Data[4]	16	DIFFERENTIAL TIME TO WARM MINUTE	AS READED		
%R2806	.i.Data[5]	16	DIFFERENTIAL TIME TO RESTART HOUR	AS READED		
%R2807	.i.Data[6]	16	DIFFERENTIAL TIME TO RSTRIT MINUTE	AS READED		
%R2808	.i.Data[7]	16	DIFFERENTIAL ON	0 = NO // 1 = YES		
%R2809	.i.Data[8]	16	DIFFERENTIAL WARM OK	0 = NO // 1 = YES		
%R2810	.i.Data[9]	16	DIFFERENTIAL FIRST READ OK	0 = NO // 1 = YES		
%R2811	.i.Data[10]	16	DIFFERENTIAL VALID (OPERATING)	0 = NO // 1 = YES		
%R2812	.i.Data[11]	16	REDING THM SENSOR NUMBER	AS READED (1 TO 125)		
%R2813	.i.Data[12]	16	RESERVED			
%R2814	.i.Data[13]	16	RESERVED			
%R2815	.i.Data[14]	16	TOTAL THM SENSOR RESPONDING	0 TO 125		
%R2816	.i.Data[15]	16	TOTAL THM SENSOR NOT RESPONDING	0 TO 125		
%R2817	.i.Data[16]	16	TOTAL ALRM ACTIVE			
%R2818	.i.Data[17]	16	TOTAL TRIP ACTIVE			
%R2819	.i.Data[18]	16	RESERVED			
%R2820	.i.Data[19]	16	RESERVED			
%R2821	.i.Data[20]	16	RESERVED			
%R2822	.i.Data[21]	16	RESERVED			
%R2823	.i.Data[22]	16	REAL TIME CLOCK DAY	1 TO 31		
%R2824	.i.Data[23]	16	REAL TIME CLOCK MONTH	1 TO 12		
%R2825	.i.Data[24]	16	REAL TIME CLOCK YEAR	0 TO 24		
%R2826	.i.Data[25]	16	REAL TIME CLOCK HOUR	0 TO 60		
%R2827	.i.Data[26]	16	REAL TIME CLOCK MINUTE	0 TO 60		
%R2828	.i.Data[27]	16	REAL TIME CLOCK SECONDS	0 TO 60		
%R2829	.i.Data[28]	16	RESERVED			

MODBUS OVER ETHERNET TCP IP SERVER

ETHERNET MODULE IN STUDIO 5000/LOGIX DESIGNER ALLEN BRADLEY

Steps to create an Ethernet module in a project in Studio 5000/Logix Designer – Allen Bradley PLCs / Zyggot Relays Connection. Let's consider that we have only 5 temperature sensors connected to the Relay.

1- OPEN YOUR PROJECT

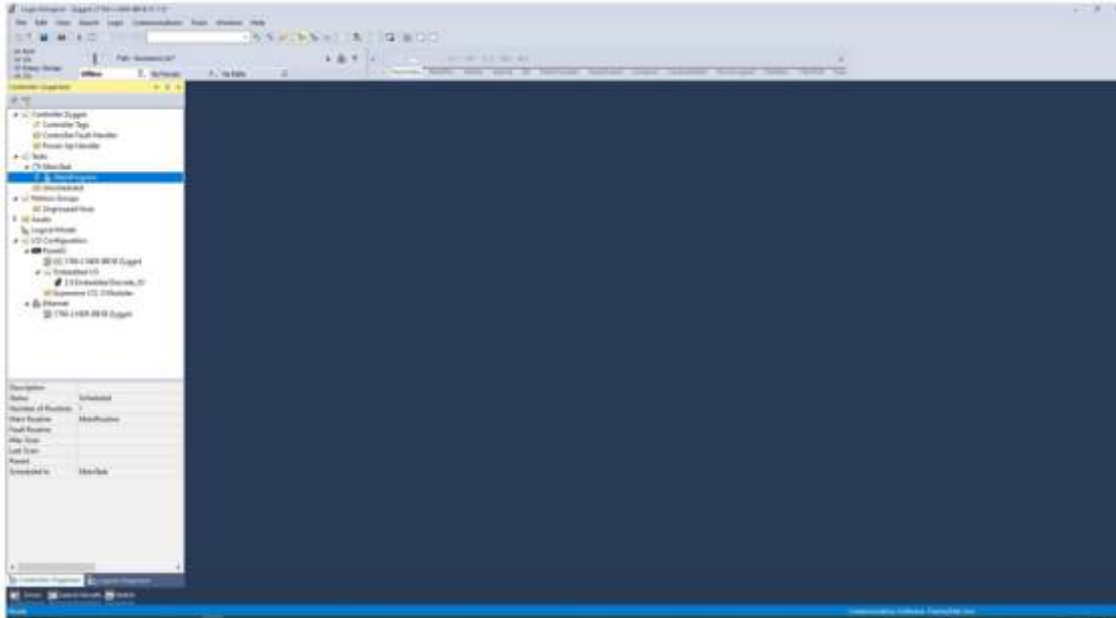

2- RIGHT CLICK ON "ETHERNET" AND THEN CLICK ON "NEW MODULE..."

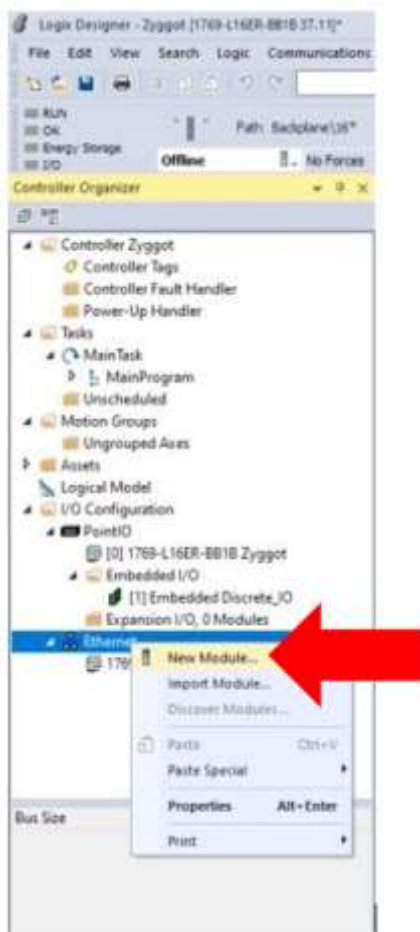

MODBUS OVER ETHERNET TCP IP SERVER

ETHERNET MODULE IN STUDIO 5000/LOGIX DESIGNER ALLEN BRADLEY

Steps to create an Ethernet module in a project in Studio 5000/Logix Designer – Allen Bradley PLCs / Zyggot Relays Connection. Let's consider that we have only 5 temperature sensors connected to the Relay.

3- IN THE “SELECT MODULE TYPE” WINDOW, SELECT THE “CATALOG” TAB AND TYPE “GENERIC” IN THE SEARCH FIELD.

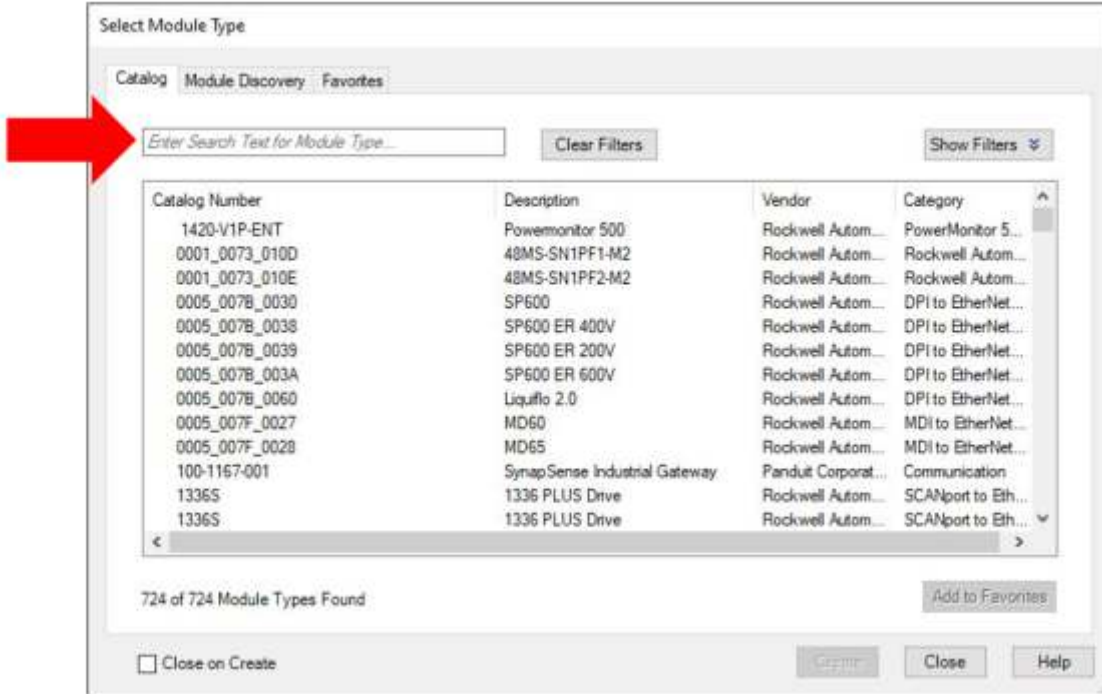

4- THEN SELECT “ETHERNET-MODULE” AND CLICK “CREATE”.

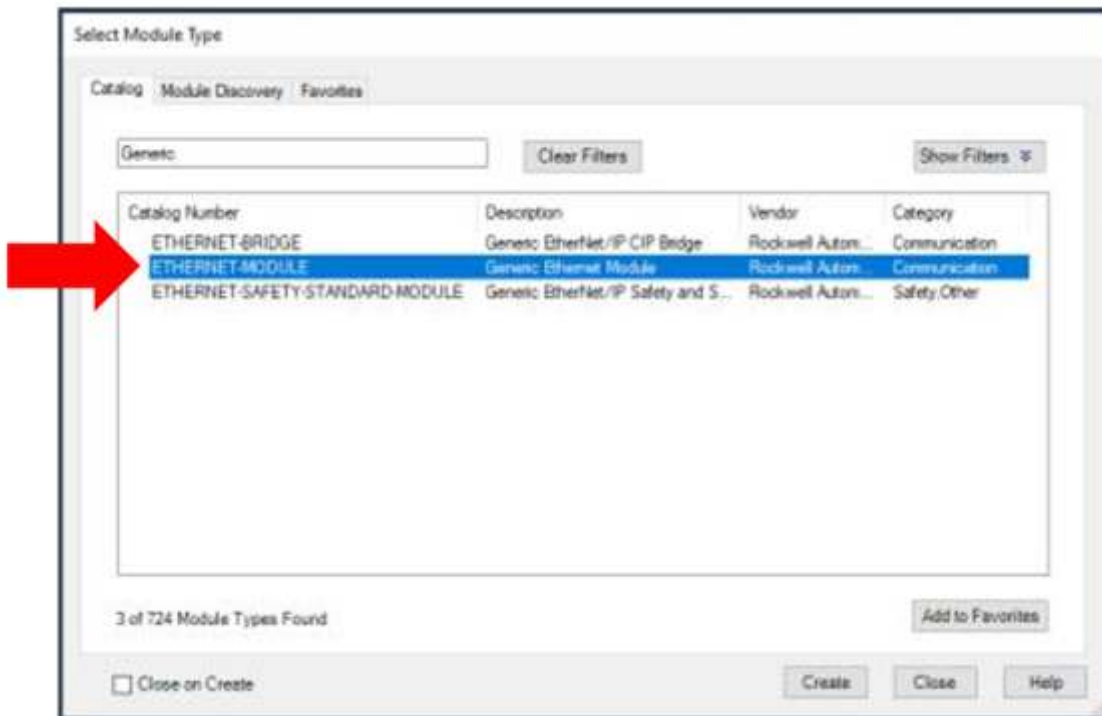

MODBUS OVER ETHERNET TCP IP SERVER

ETHERNET MODULE IN STUDIO 5000/LOGIX DESIGNER ALLEN BRADLEY

Steps to create an Ethernet module in a project in Studio 5000/Logix Designer – Allen Bradley PLCs / Zyggot Relays Connection. Let's consider that we have only 5 temperature sensors connected to the Relay.

5- IN THE “NEW MODULE” WINDOW:

- IN THE “COMM FORMAT” FIELD, CHOOSE THE “DATA – INT” OPTION
 - IN “IP ADDRESS”, ENTER THE IP THAT WAS CONFIGURED IN THE ZYGGOT RELAY
 - IN “ASSEMBLY INSTANCE” OF THE INPUT, ENTER “100”
 - IN “SIZE” INPUT, ENTER “128”
 - IN “ASSEMBLY INSTANCE” OUTPUT, ENTER “101”
 - IN “SIZE” OUTPUT, ENTER “128”
 - IN “ASSEMBLY INSTANCE” CONFIGURATION, ENTER “3”
 - IN “SIZE” CONFIGURATION, ENTER “0”
- THEN CLICK “OK”.

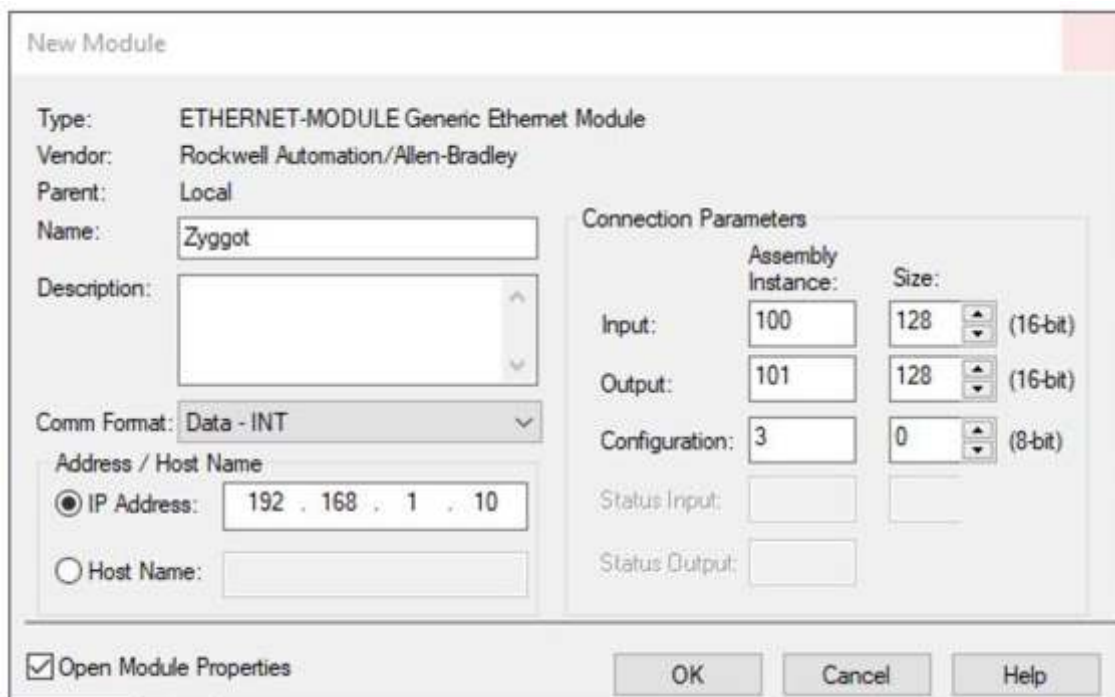

New Module

Type: ETHERNET-MODULE Generic Ethernet Module
 Vendor: Rockwell Automation/Allen-Bradley
 Parent: Local
 Name: Zyggot
 Description:
 Comm Format: Data - INT
 Address / Host Name
 IP Address: 192 . 168 . 1 . 10
 Host Name:
Connection Parameters
 Input: Assembly Instance: 100, Size: 128 (16-bit)
 Output: Assembly Instance: 101, Size: 128 (16-bit)
 Configuration: Assembly Instance: 3, Size: 0 (8-bit)
 Status Input:
 Status Output:
 Open Module Properties
 OK Cancel Help

MODBUS OVER ETHERNET TCP IP SERVER

ETHERNET MODULE IN STUDIO 5000/LOGIX DESIGNER ALLEN BRADLEY

Steps to create an Ethernet module in a project in Studio 5000/Logix Designer – Allen Bradley PLCs / Zyggot Relays Connection. Let's consider that we have only 5 temperature sensors connected to the Relay.

6- DOWNLOAD THE PROJECT TO THE PLC.

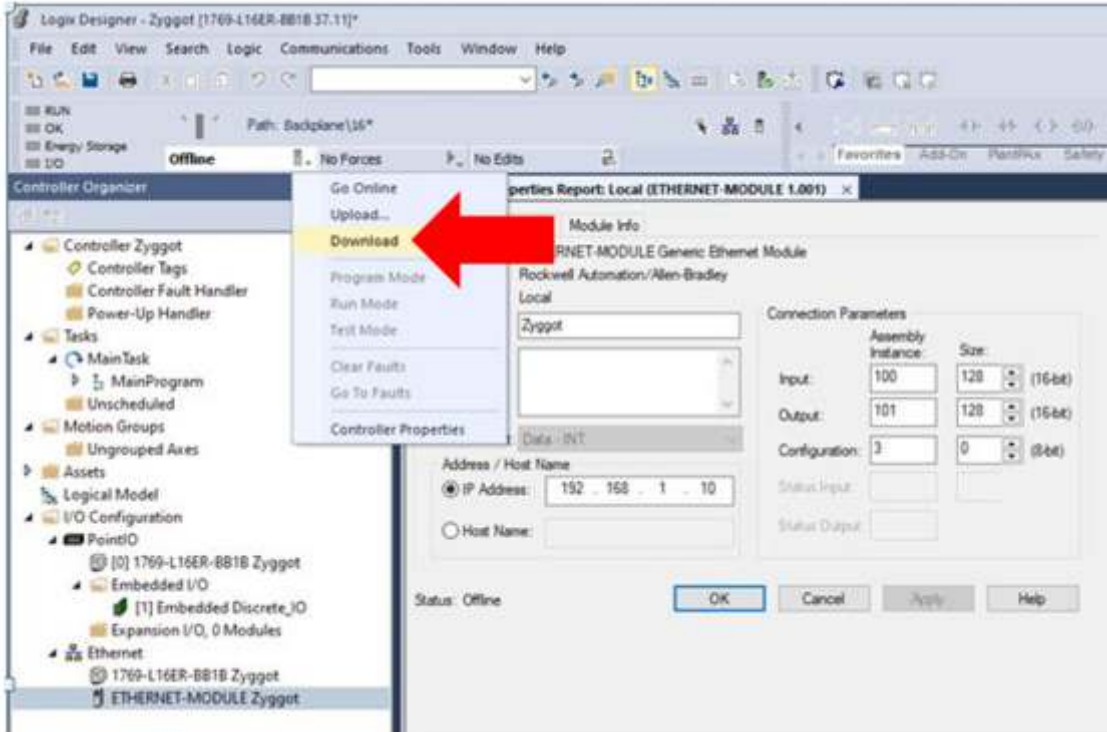

7- TESTING: READING THE TARGET TEMPERATURE OF THE 5 SENSORS CONNECTED TO THE RELAY.

7a- LEAVE THE PLC IN RUN MODE BY THE SYSTEM AND DOUBLE CLICK ON "CONTROLLER TAGS".

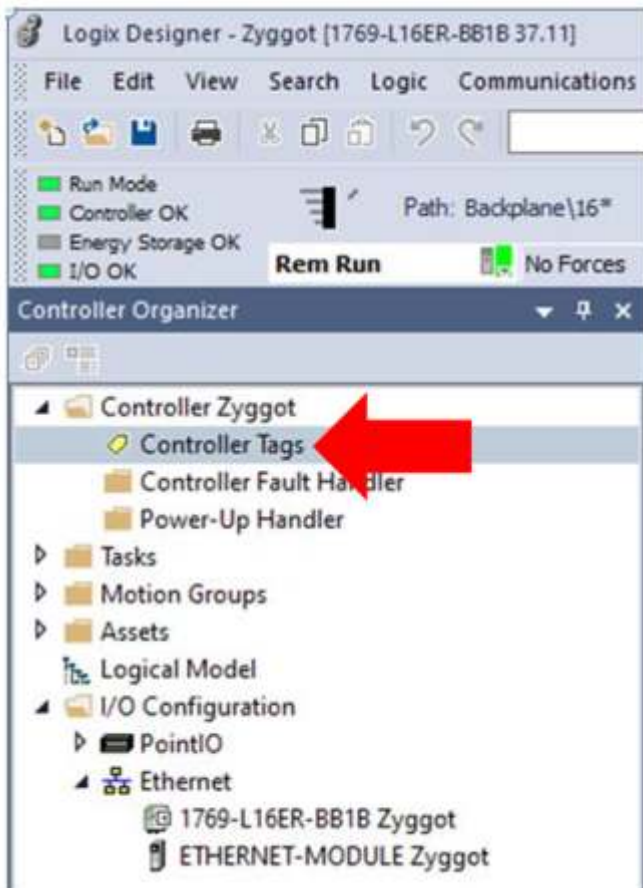

MODBUS OVER ETHERNET TCP IP SERVER

ETHERNET MODULE IN STUDIO 5000/LOGIX DESIGNER ALLEN BRADLEY

Steps to create an Ethernet module in a project in Studio 5000/Logix Designer – Allen Bradley PLCs / Zyggot Relays Connection. Let's consider that we have only 5 temperature sensors connected to the Relay.

7b- SELECCIONA COMO MOSTRADO.

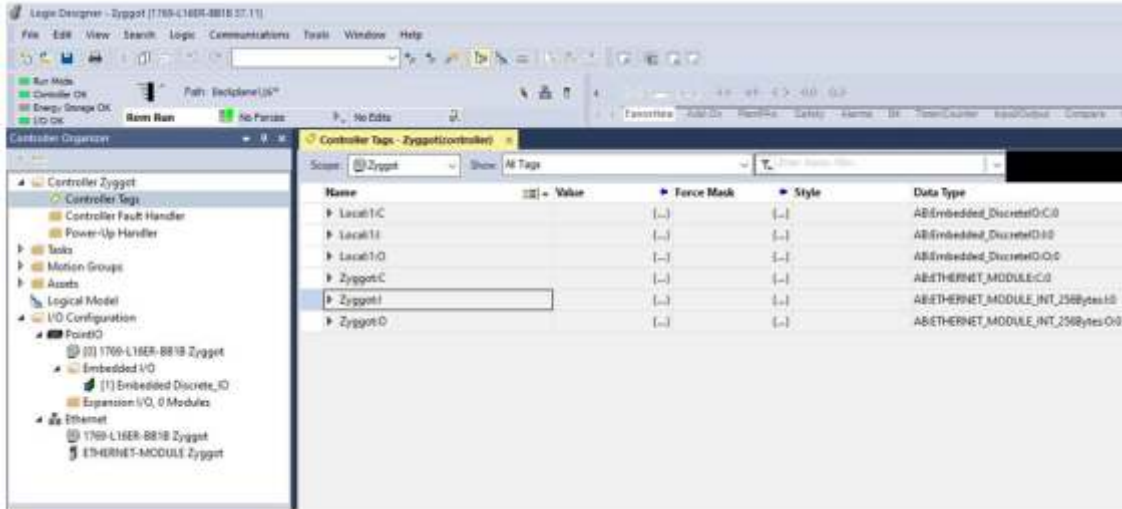

7c- FIND THE OUTPUT RECORD "...0.DATA[126]" (%R3327) AND MAKE SURE IT HAS THE VALUE "1," OTHERWISE, ASSIGN IT THE VALUE "1" (THIS WILL SELECTE PAGE 1, THIS «PAGE» IS REFERENT TO THE SYSTEM TARGET TEMPERATURE VALUES).

Zyggot:O.Data[120]	0	Decimal	INT
Zyggot:O.Data[121]	0	Decimal	INT
Zyggot:O.Data[122]	0	Decimal	INT
Zyggot:O.Data[123]	0	Decimal	INT
Zyggot:O.Data[124]	0	Decimal	INT
Zyggot:O.Data[125]	0	Decimal	INT
Zyggot:O.Data[126]	1	Decimal	INT
Zyggot:O.Data[127]	0	Decimal	INT

7d - NOW FIND THE INPUT REGISTER "...I.DATA[0]" (%R2801), DIVIDING THE RECEIVED VALUE BY 10, WE WILL HAVE THE TARGET TEMPERATURE OF SENSOR 1. IN THE REGISTER "...I.DATA[1]" (%R2802) WE HAVE THE TARGET TEMPERATURE OF SENSOR 2 AND SO ON. IN THE IMAGE BELOW WE HAVE THE TEMPERATURE VALUES OF THE FIRST 5 SENSORS READ BY THE RELAY (NOT YET DIVIDED BY 10).

Name	Value	Force Mask	Style	Data Type
Local:I:C	[...]	[...]	[...]	AB:Embedded_DiscretelO:C:0
Local:I:I	[...]	[...]	[...]	AB:Embedded_DiscretelO:I:0
Local:I:O	[...]	[...]	[...]	AB:Embedded_DiscretelO:O:0
Zyggot:C	[...]	[...]	[...]	AB:ETHERNET_MODULE:C:0
Zyggot:I	[...]	[...]	[...]	AB:ETHERNET_MODULE_INT_256Bytes:I:0
Zyggot:I.Data	[...]	[...]	[...]	INT[128]
Zyggot:I.Data[0]	233			Decimal INT
Zyggot:I.Data[1]	232			Decimal INT
Zyggot:I.Data[2]	224			Decimal INT
Zyggot:I.Data[3]	211			Decimal INT
Zyggot:I.Data[4]	245			Decimal INT
Zyggot:I.Data[5]				Decimal INT
Zyggot:I.Data[6]	0			Decimal INT
Zyggot:I.Data[7]	0			Decimal INT
Zyggot:I.Data[8]	0			Decimal INT
Zyggot:I.Data[9]	0			Decimal INT

BT SENSOR TEST REPORT

CAN BE EXTENDED TO THE TUBULAR SENSOR BY SIMILARITY

Zyggot BT Sensor Analysis Report

Date: 10/04/2022

Objetive

Check the reliability of temperature measurements using the Zyggot BT sensor

Used equipments

Equipment	Fabricante	Modelo	Número de Série
4 CH 100MHz Oscilloscope	Keysight	DSOX 3014T	MY55120213
Infrared Thermometer Calibrator	Fluke	9133	CO6729
DC Power Supply 24V 60W	Varixx	VPS6024	VFE22132
Zyggot Relay Model V5L/V5F	Varixx	VZX/B1/U	SRT1003315
125 Zyggot Temperature Sensor Model V5L/V5F	Varixx	ZSB/M/60/120	SBT1037459 ao SBT1037584

Temperature ramp response curve

Measurement performed using a Zyggot BT sensor pointed at the target ranging from 0 to 120°C

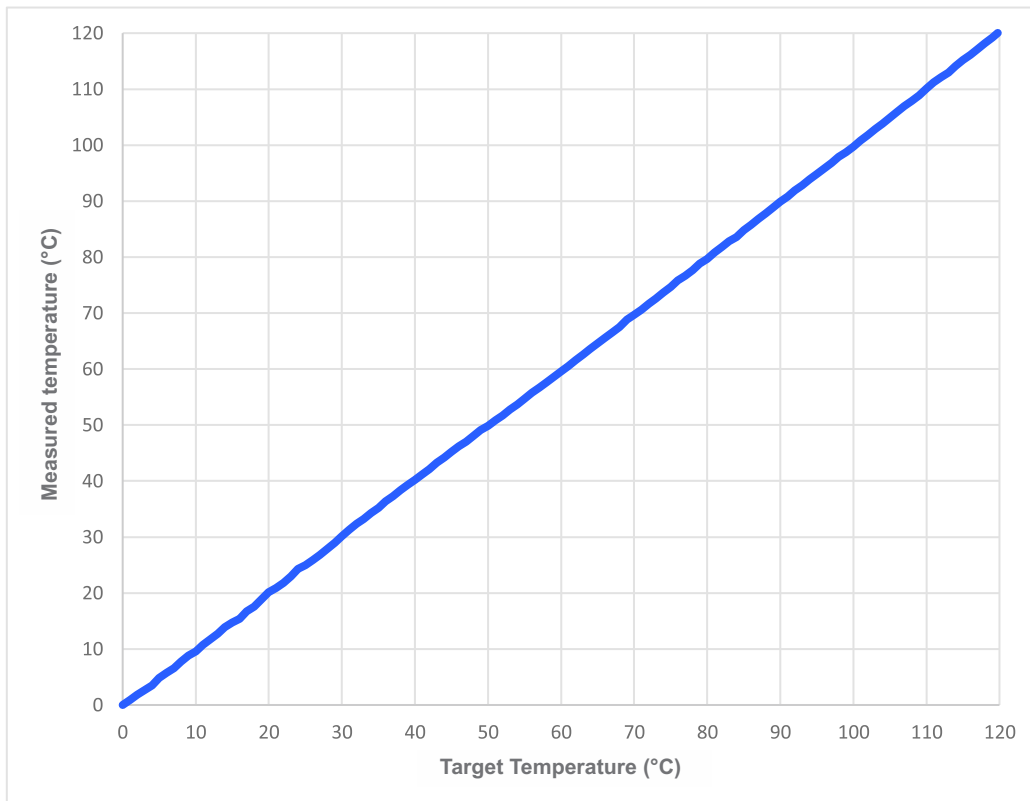

Maximum absolute error: 0.6°C
Standard Deviation: 0.23°C

Measurement distribution of 125 sensors targeting at 80°C

Measurement carried out with 125 sensors connected in a network in the Zyggot relay and with a fixed target at 80°C

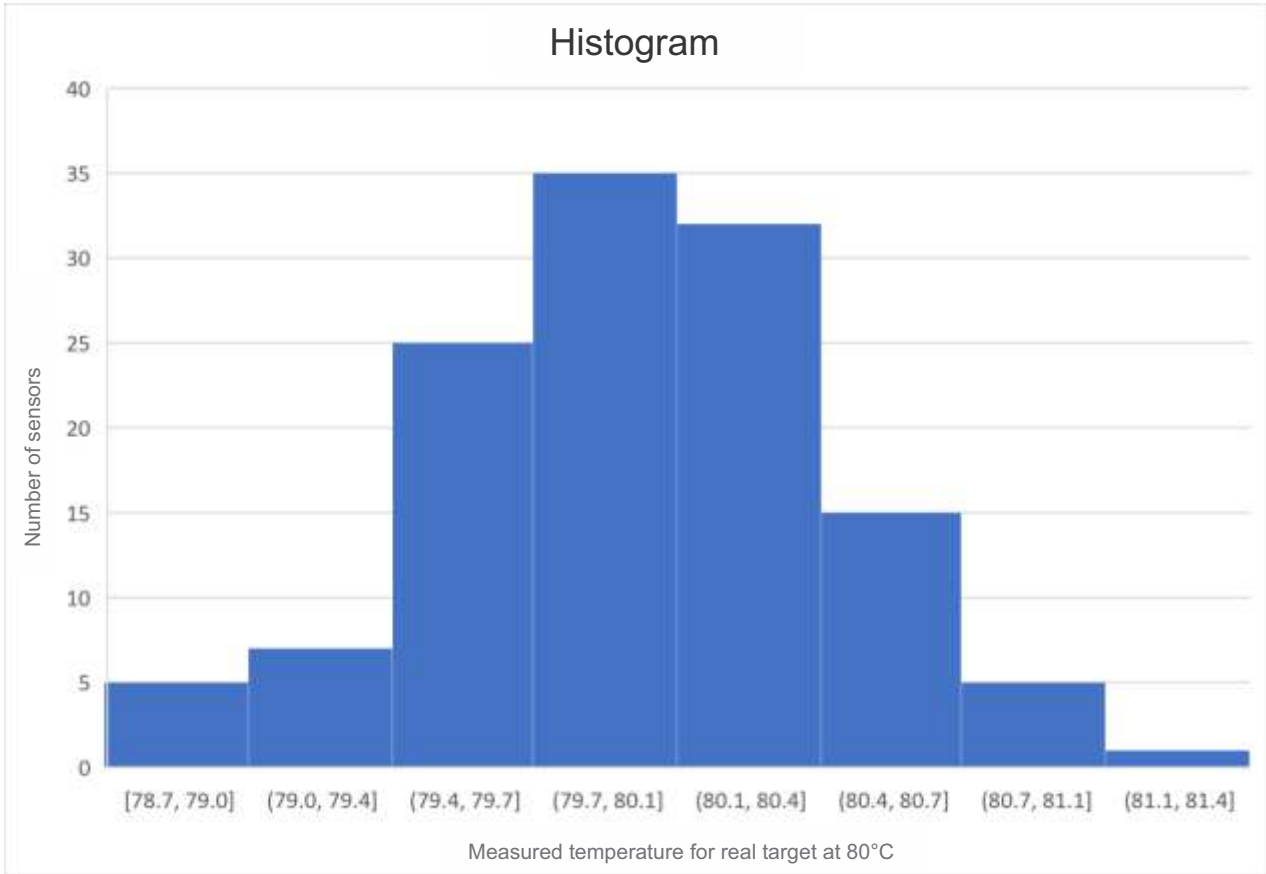

Maximum absolute error: 1.3°C

Standard Deviation: 0.48°C

ABOUT VARIXX

For over 40 years, Varixx has followed its vocation for the development of high technology products and focuses its efforts on serving the industrial market with quality and speed. The know-how in power electronics has allowed us to offer the market a wide range of products that have become known for their long service life and reliability. We were the creators of the global online thermography market, with the Zyggo line, which is becoming a world reference in the market for temperature monitoring and diagnostics and arc-flash detection, in electrical systems in general. Also part of our product portfolio are the LED lighting fixtures from our ONNO division, developed and manufactured 100% in Brazil with cutting-edge technology. Varixx values the introduction of innovative concepts worldwide.

AREAS OF EXPERTISE

- ✓ **MANUFACTURERS OF MACHINE GENERATORS AND SYNCHRONOUS MOTORS**
Static Exciters, Control Box Controllers, Low and Medium Voltage Soft
- ✓ **ALUMINUM AND HYDROGEN / OXYGEN PRODUCTION**
High Current Rectifiers, Solid State Contactors, Smart Relay for CCM, Online Thermography System and Arc Voltage Detection and Onno LED Luminaires.
- ✓ **BASE INDUSTRY, MINING AND STEEL INDUSTRY**
Smart Relays for CCM's, Low and Medium Voltage Soft Starters, Solid State Contactors, AC/DC Converters for Electromagnets, High Current Rectifiers, Online Thermography System, Arc Voltage Detection and Protection and Onno LED Luminaires.
- ✓ **OIL COMPANIES**
Smart Relays for CCM's, Static Excitation, Low and Medium Voltage Soft Starters, Solid State Contactors, Online Thermography System, Arc Voltage Detection and Protection and Onno LED Luminaires.
- ✓ **PANEL ASSEMBLY COMPANIES**
Smart Relays for CCM's, Online Thermography, Arc Voltage Detection and Protection System, Semiconductors, Power Supplies and Onno LED Luminaires.

Why ZYGGOT Thermography?



SINGLE CABLE / EASY TO INSTALL



PREDICTIVE / DIFFERENTIAL PROTECTION



ADEQUACY TO NR-10 AVOID ACCIDENTS



AVOID OPENING PANEL / AVOID CATASTROPHIC FAILURES



WAIVER CONVENTIONAL THERMOGRAPHY / MEASURE AIR TEMP. TOO



NO CONTACT / WITH ETHERNET COMMUNICATION

KNOW MORE!



ZYGGOT ARC

ARC FLASH PROTECTION SYSTEM

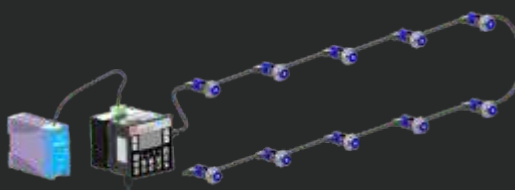

- ✓ **Low Cost // Up to 50 sensors per relay.**
- ✓ **First in the market // Faster (300 uS vs 6 mS)**
- ✓ **Ultraviolet arc-flash detection**
- ✓ **Does not work with ambient light (False Alarm)**
- ✓ **No current reading**

varixx

ALWAYS AN ORIGINAL IDEA

www.varixx.com
www.varixx.com.br
vendas@varixx.com.br
+55 (19) 3424-4000
+55 (19) 3301-6900

R. Felipe Zaidan Maluf, 450
Distrito Industrial Unileste
Piracicaba-SP. CEP: 13422-190



@Varixxbrasil



@varixxcompany



Varixx Indústria Eletrônica



www.varixx.com.br

Representative/Distributor:



ZYGGOT THERMOGRAPHY