

MANUAL VERSION 6P

WIRING VERSION and relays VZX/VZT



ZYGGOT TEMPERATURE CONTACTLESS MONITORING AND PROTECTION SYSTEM OF TEMPERATURE

MODEL: TUBULAR SENSOR

INDEX

DESCRIPTION	4
CAPTURE OF TEMPERATURE MEASURE AND INFLUENCE OF EMISSIVITY	5
MEASUREMENT	5
UNIDEX TAPE	5
POSITIONING OF THE SENSORS AND READING OF THE TEMPERATURE	6
ÂNGULO DE VISADA	6
FIXATION OF THE SENSORS	6
SUPPORT	6
RELAY	6
PRODUCT ITENS SET	7
POWER SUPPLY	7
ZTA SHUNT	7
MINI USB CABLE	7
INSTALLATION AND MAINTENANCE BRIEFCASE/PACK	7
LASER AIMING POINTER	7
USB SET UP CABLE	7
ONE LINE DIAGRAM AND PRINCIPAL CHARACTERISTICS	8
WIRING DIAGRAM	9
RELAY INSTALLATION AND LOW-VOLTAGE CIRCUITS	12
FUNCTION TABLE	13
INTEGRITY TEST	13
OVERLAY	13
TECHNICAL SPECIFICATIONS	14
General Specifications	14
Rear Junction Box	14
Profibus-DP Specifications	14
Digital Inputs	15
Digital Outputs	15
Sensors Specifications	15
Power Supply	15
TECHNICAL SPECIFICATIONS MODEL VZX	16
TECHNICAL SPECIFICATIONS MODEL VZT	17
MECHANIC MODELS VZX AND VZT	18
DISPLAY MANUAL	19
SUMMARY OF PROGRAMMING AND OPERATION	21
RELAY DISPLAY FUNCTIONS MODEL VZX	22
RELAY DISPLAY FUNCTIONS MODEL VZT	28
PARAMETERIZATION BY RELAY	34
SUBMENU RELAY CONFIGURATION	34
SUBMENU PARAMETERIZATION CONFIGURATION	34
SUBMENU SENSORS	34
SUBMENU SENSOR BLOCK PROGRAMMING	34
SUBMENUS ANALOG INPUTS	34
SUBMENU MODBUS	34
SUBMENU COMMUNICATION SENSOR	34
SUBMENU ALARM LEVELS POINTS	34
SUBMENU TRIP LEVELS POINTS	34
SUBMENU TRENDING CONFIGURATION	34
SUBMENU CLEAR DATA	35
SUBMENU PROTECTIONS	35
SUBMENU PROTECTIONS 1/3	35
SUBMENU PROTECTIONS 2/3	36
SUBMENU PROTECTIONS 3/3	36
PARAMETERIZATION BY COMPUTER	37
SENSOR CONFIGURATION	38
SUPERVISORY SOFTWARE	40
OPERATION	41
HOW TO	45
MODBUS RECORDS MAP	47
MODBUS RECORDS MAP	49

CONTACTLESS ONLINE THERMOGRAPHY SYSTEM



DESCRIPTION

ZYGGOT TEMPERATURE was elaborated so it can monitors components temperatures and internal connections of low and medium voltage electric panels, engines, generators and others devices.

The system introduces an innovation in the market: the new safety standards inhibit the opening of energized electrical panels for any type of measuring, including temperature measurements with manual pistol of point measuring or thermographic cameras. ZYGGOT System monitors temperatures without contact of buses and components of low and medium voltage panels without risk to the operator or panel.

The system is compounded of at least one relay and one sensor. The information of the measured temperatures by each sensor are sent through a communication network to the relay. There is the possibility of monitoring until 125 selected points (targets) of temperature. For each target, one sensor must be used.

The sensors have opening angle of 7°, enabling monitoring not only point focused areas but also areas of just a few square centimeters. The distance between the sensor and the target defines the size of the measuring area. An important characteristic of the sensor is the simultaneous measurement of temperature of the target and the sensor case (which is equal to the surrounding air temperature). This allows detecting internal temperature elevations in the panels, identifying obstructions, ventilation failure or even temperature elevation of points not directly monitored.

The relay has the function of performing the temperature degrees reading. of the sensors and inform the user, the temperature of each target. Six digital outputs are available: one of them acts when any target reaches temperature above the alarm level (alarm 1) and the other acts when the temperature is above the trip level (alarm 2). The others outputs are configurable.

The method of transmitting data between sensors and relay available is:

physical layer RS-485 communication, with all the sensors connected in parallel using shielded cables with mini-USB connectors which allow quick installation and operation. The systems Zyggot Temperature BT and Zyggot Tubular Temperature use this method of communication. This manual approaches the system Zyggot Tubular Temperature.

The relay of the Zyggot Temperature system can be connected to a communication network by intercommunication with supervisory system or remote monitoring. Two versions of relay are available: one with Modbus RTU protocol and other with PROFIBUS-DPS protocol.

APPLICATION

Temperature monitoring and online protection of internal connections of low and medium voltage electric panels, engines, generators and others devices.

BENEFITS

- ✓ Contactless measurement;
- ✓ Avoids energized panel door opening;
- ✓ No need for periodic thermography;
- ✓ Provides reading of target and sensor;
- ✓ Indicates eventual sensor failure;
- ✓ Provides failure history.

CHARACTERISTICS

- Applicable in low and medium voltage;
- Network with shielded cables and mini-USB connections;
- Sensors supplied in 24 VCC;
- Measurement angles of 7°;
- Online reading
- 2 types of relays, being one with graphic display and communication and another with touch screen display;
- Failure history with "Time Stamp" of the 120 last fails;
- Reading and protection of over-temperature up to 125 target points or areas;
- Over-temperature reading and protection of up to 125 points targets or areas;
- Readings and protections for 4 analog inputs;
- Monitoring of 8 external fails;
- 6 configurable digital outputs;
- Modbus RTU Communication or PROFIBUS-DP;
- LED integrated in the sensor that flashes to detect fails or localization.

TEMPERATURE MEASUREMENT CAPTURE AND INFLUENCE OF EMISSIVITY MEASUREMENT



Every object with temperature above absolute zero radiates electromagnetic energy. This radiation in the infrared region is not visible, as shown in the figure.

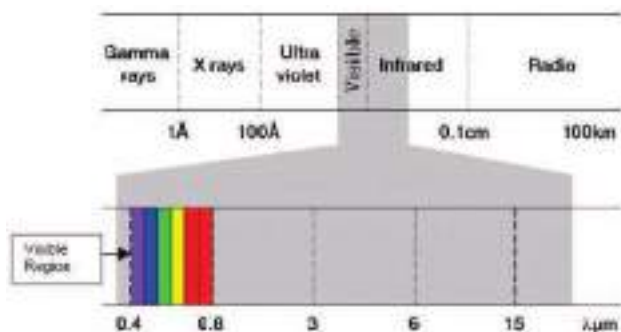

When the radiation of an object reaches another object, a part of the energy is absorbed, a part is reflected and if the case is not matte, a portion is transmitted. The sum of the parts shall be always equal to the total amount that hits the object.

Considering this facts, in order to detect the temperature from selected targets, there must be sensors that receive such electromagnetic energy.

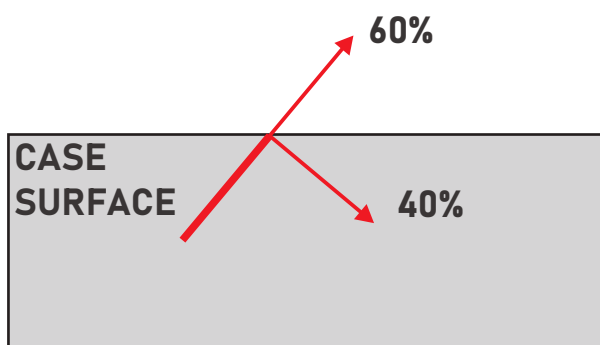
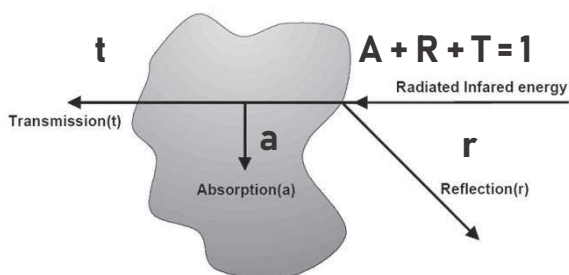

When heating a material, its surface does not absorb all the energy and ends up emitting energy in infrared. In practice, there is no material which is an ideal emitter of infrared radiation. The ideal emitter is named black body. Objects may radiate less energy than the black bodies, even at the same temperature.

The emissivity of an object is defined by:

$$\epsilon = t/b$$

ϵ = Emissivity;
 t = radiation emitted at a given temperature;
 b = radiation emitted by a black body at the same temperature.

The table below shows the variation of the emissivity from material to material.

MATERIAL	EMISSIVITY (1µm)
Iron and steel	0,35
Iron and oxidized steel	0,85
Aluminum	0,13
Oxidized aluminum	0,40
Copper	0,06
Oxidized cooper	0,80
Brick	0,80
Asphalt	0,85
Asbestos	0,90

There are some portable meters that do not have the possibility of varying the emissivity index which leads to erroneous measurements since this index is fixed at 0,95. Zyggot sensors allow the configuration of the emissivity index, ensuring precise measurements in any material.

UNIDEX TAPE

Solution for the variations of emissivity

Most metals have alteration of emissivity due to oxidation. One example is copper, which in normal condition has emissivity of 0,06 and when oxidized 0,80.

To avoid emissivity calibration readjustments of the sensors, Zyggot system supplies Unidex tape for temperatures up to 250°C, which values of emissivity of 0,95 is known and guaranteed by Varixx. The Unidex tape stuck over the target measuring area always provide real reading of the temperature, regardless the emissivity of the material.

Using the tape, it is not necessary calibrating different index for each material.

The tape is supplied in dimensions of 50mmx50mm or in roll of 30cm. For each sensor acquired by the client, one unity of the tape is provided.

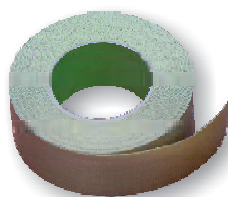

UNIDEX ROLL TAPE
30m (ref. ZU3000)



Units of UNIDEX TAPE
50m x 50m (ref. ZU50)

TEMPERATURE MEASUREMENT CAPTURING AND PRODUCT COMPOSITION



SENSORS POSITIONING AND TEMPERATURE READING

Each sensor measures, at the same time, the temperature of the target and the temperature of its case (which is equal to the temperature of the surrounding air).

For the correct positioning of the sensors in the pre-defined measuring area, an aiming laser should be connected in the front side of the sensor and directed to the center of the measuring area, as shown in the figure below.

The measuring area diameter in the selected target must be selected so the distances gaps between sensor can be estimated. The distance between the measuring area and the sensor is up to 8 times the value of the diameter of the measuring area for 7° sensors. The maximum distance of the target should be less than 10 meters.

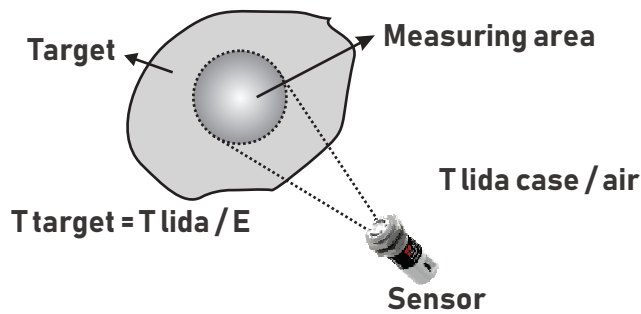

VIEWING ANGLE

The viewing angle is the angle between an area perpendicular to the target area and the axis traversing the sensor longitudinally. The curve below shows that it would only decrease of the emissivity after 55° of angle in relation to the perpendicular of the measured object. The use of a maximum viewing angle of 45° is recommended.

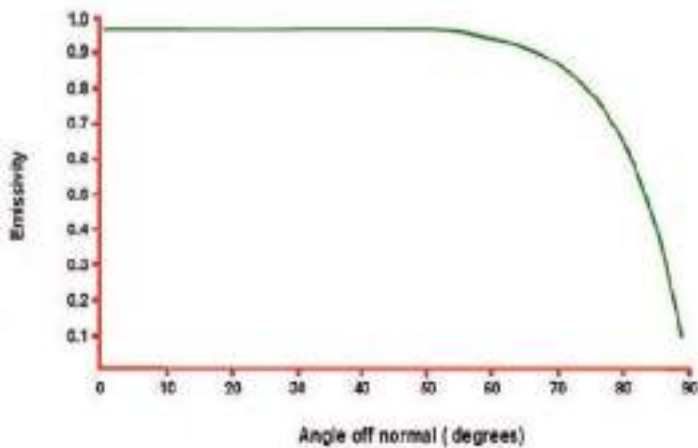

FIXATION OF THE SENSORS

Fix the sensor in the appropriate place using the threaded nuts.

SENSOR – TWO MINI-USB CONNECTIONS



tubular sensor (ref. ZST/M7/300/24)

SUPPORT – Adjustable fixation support

Mechanic support that can be used for the correct directioning of the sensor in relation to the target, facilitating the installation.



fixation support (ref. ZSF1)

RELAY

The relays are available in two different models.
 Modbus RTU Communication (VZX/B1/U)
 Modbus RTU Communication and Touch Screen display (VZT/B1/U)

To use PROFIBUS-DP communication add /P at the end of the code.
 Example: VZX/B1/U/P



Modbus RTU Relay (ref. VZX/B1/U)



Modbus RTU Relay Touch Screen (ref. VZT/B1/U)

PRODUCT ITENS SET



POWER SUPPLY

The system Zyggot Tubular Temperature must be powered by an external supply. The supply VPS12024 has the capacity to provide the 24 VCC that are necessary to power the relay and the sensors.

Input: 90~132 / 180~264 VCA
120~375 VCC
Output: 24VDC/5A - 120W



Supply VPS 12024
REF: VPS12024

ZTA SHUNT

ZTA SHUNT (T connector) allows various types of topologies and layouts, facilitating the system installation. For further information, see pages 9, 10 and 11.

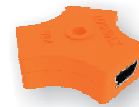

ZTA Shunt
REF: ZTA

MINI-USB CABLE

MINI-USB cable performs the communication between sensors and sensors/relays. The cables are available in the following sizes:

- 0,3m - ZCB/4/2U/030
- 0,5m - ZCB/4/2U/050
- 1,0m - ZCB/4/2U/100
- 2,0m - ZCB/4/2U/200
- 4,0m - ZCB/4/2U/400
- 6,0m - ZCB/4/2U/600
- 8,0m - ZCB/4/2U/800



MINI-USB CABLE

INSTALLATION AND MAINTENANCE CASE/PACK

Zyggot Temperature Installation and Maintenance case (ref. VLP5) contains essential tools for the installation and maintenance of the sensor and relay. Such tools are: laser aiming pointer (ref. VLP2) and configurator USB cable. Is important that this briefcase is in possession of the Zyggot Temperature System user, in order to perform any maintenance appropriately.



INSTALLATION BRIEFCASE

LASER AIMING POINTER

Aiming Laser is an essential tool to direct the sensor to the selected target. The aiming facilitates the installation. The system is powered by a long life battery.

USB SET UP CABLE

Configurator USB cable (ref. ZCC180) is used to connect the tubular sensor to PC. It enables the configuration of each sensor through the Zyggot managing software.

USB SET UP CABLE



LASER AIMING POINTER

ONE LINE DIAGRAM AND MAIN FEATURES

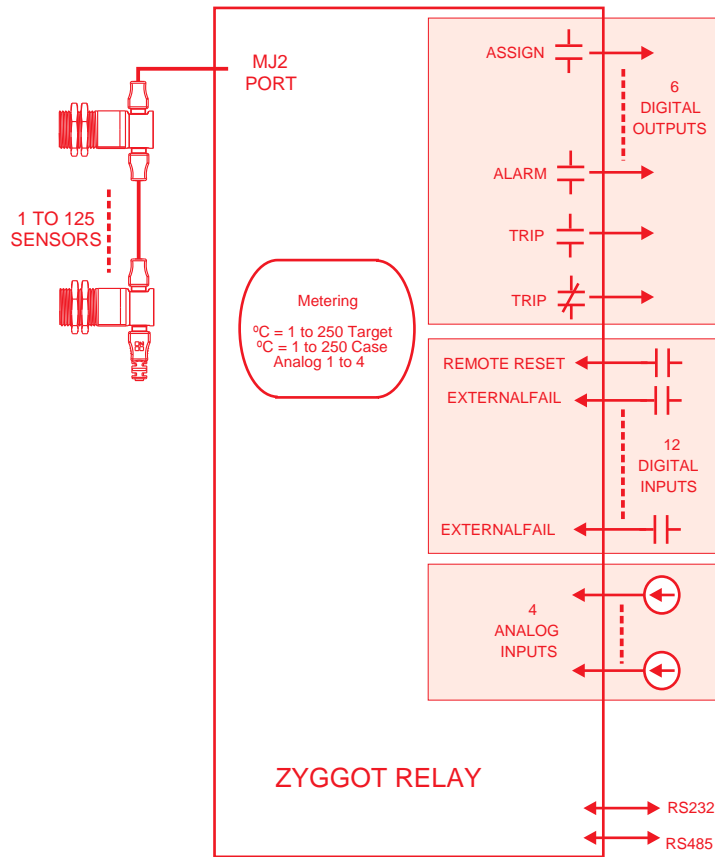

Programming Tools

A Varixx developed software is provided costless to make relay parameter setting even easier. Even without the software, there is no complexity in parameterizing the relay by the HMI that has interactive and friendly menus. Another program tests and parameterizes each sensor (emissivity and address).

Failure Event Memory

The relay allows memorization and indication of the last 120 failure with date and time of occurrence. These indications are not lost even if the relay is turned off.

Communication Ports

The relay has two communication ports, one programmable (RS-232 / RS-485) for communication with supervisory or CLP via Modbus RTU protocol*. The other communication port is for the sensor network.

* Optionally you can acquire the relay with PROFIBUS-DP communication protocol.

Analog Inputs

4 10 bits analog inputs are available, which can be used for measurement and protection, connected to external transducers of temperature and others.

Digital Inputs

There are 12 digital inputs, being 8 configured for external fails, which may be, for example, connected to the panel door micro switch or ventilation air flow sensors.

Digital Outputs

6 digital outputs are available with an alarm, one of trip and 4 configurable ones.

Topology

The tubular sensors allow quick and easy installation and parameterization, with the target emissivity insertion into the internal memory of each sensor.

Fixation Support

A mechanical support to which the sensor fits, allows easy adjustment of the measuring point.

Measurement

Zyggot relay provides accurate measurement of:

- Up to 125 temperatures targets or areas;
- Up to 125 temperatures of the sensor body
- 4 a10 bits analogue inputs for measuring and protection of external variables, and others temperatures acquired by thermocouples and others;
- Operating hours.

Display

The 2 types of relays available have graphic display, with trending capacity. The trending shows in real time graphics (maximum 3 variables by graphic), the recording behavior of any temperature or analog input. One of the relays feature Touch Screen display in two colors and 3,5".

Laser Aiming

A laser pointer that threaded on the front of the sensor case, only during the installation, allows quick and secure fixation of the sensors, being removed after it. A single pointer is necessary and enough.

CONNECTION DIAGRAM

The Zyggot Tubular Temperature System has 03 different topologies for the sensor connection network Connection examples will be presented with the appropriate limits to be respected to ensure the correct functioning of the system.

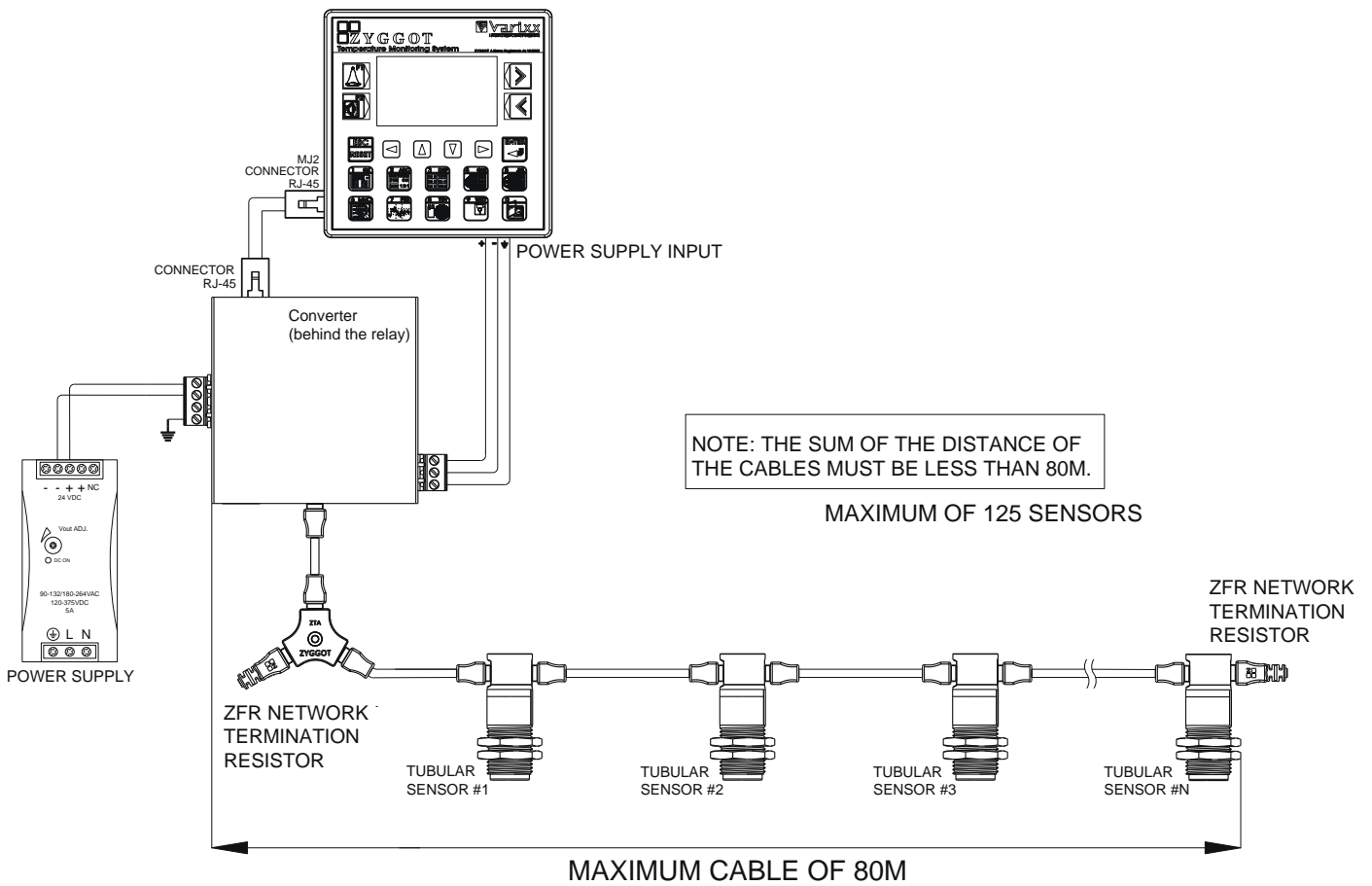

CONNECTION DIAGRAM

MAXIMUM OF 125 SENSORS

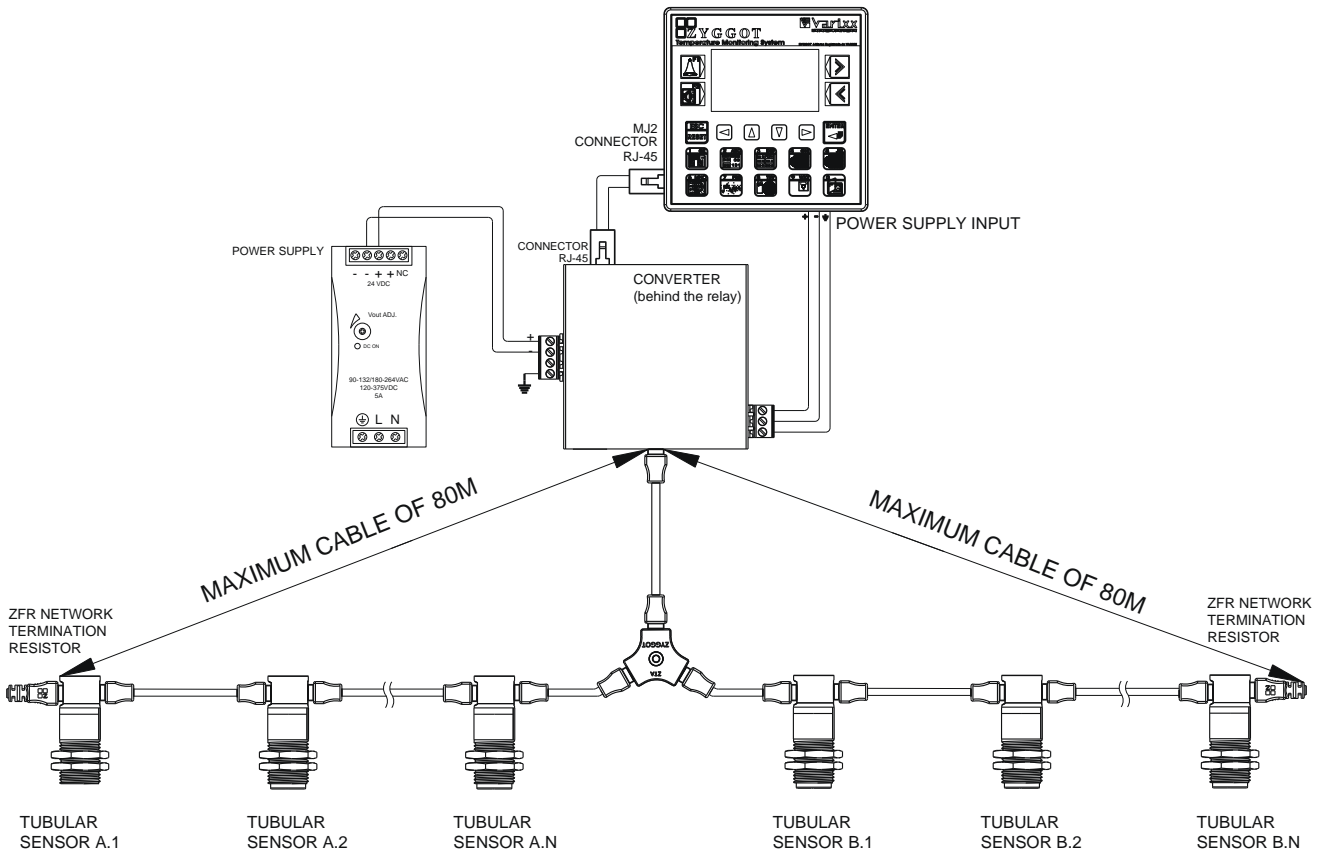

NOTE: FOR EACH BRANCH, THE SUM OF THE DISTANCE OF THE CABLES MUST BE LESS THAN 80M.

CONNECTION DIAGRAM

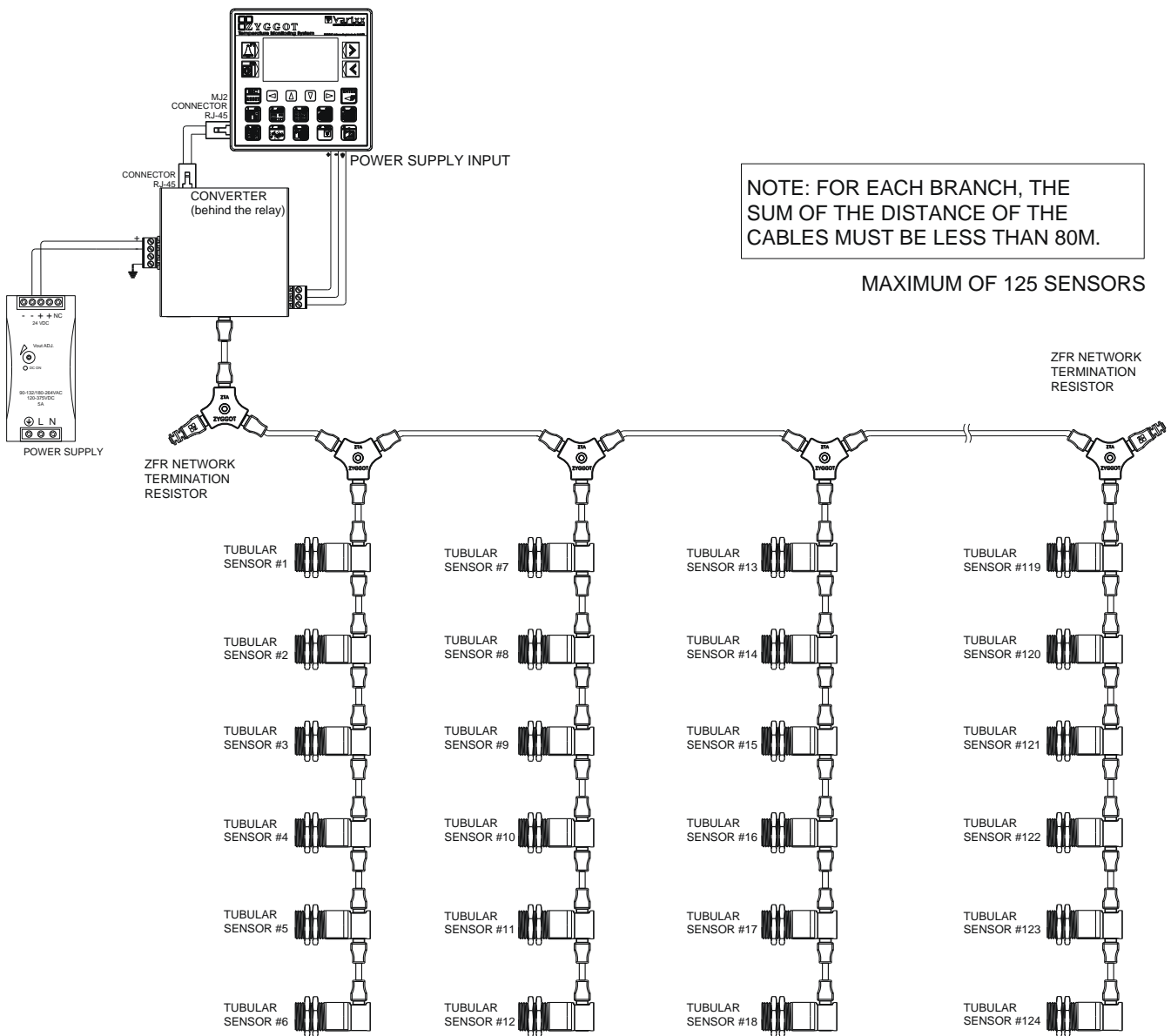

POWER AND COMMAND CONNECTION

Once the entire system is mechanically installed, make the low voltage electrical connections.

For the monitoring relay, follow the connections, according to the diagram below.

There are 8 for external fault digital inputs, one Reset input and one operating input, which are used to inform that the equipment has started operation, starting the Warm-up time count.

4 programmable digital auxiliary outputs are available; an output of Alarm/Alarm1 and output of Trip/Alarm2.

4 analog inputs of 4 - 20 mA are available in order to monitor external quantities.

The Zyggot relays have 2 communication ports being one configurable (RS232 / RS485). This is for communications with supervisory systems or CLPs via Modbus communication protocol and the other for the sensors network.

Optionally it can be supplied with PROFIBUS-DP port. In this configuration the relay has dual communication channel (Modbus RTU and PROFIBUS-DP).

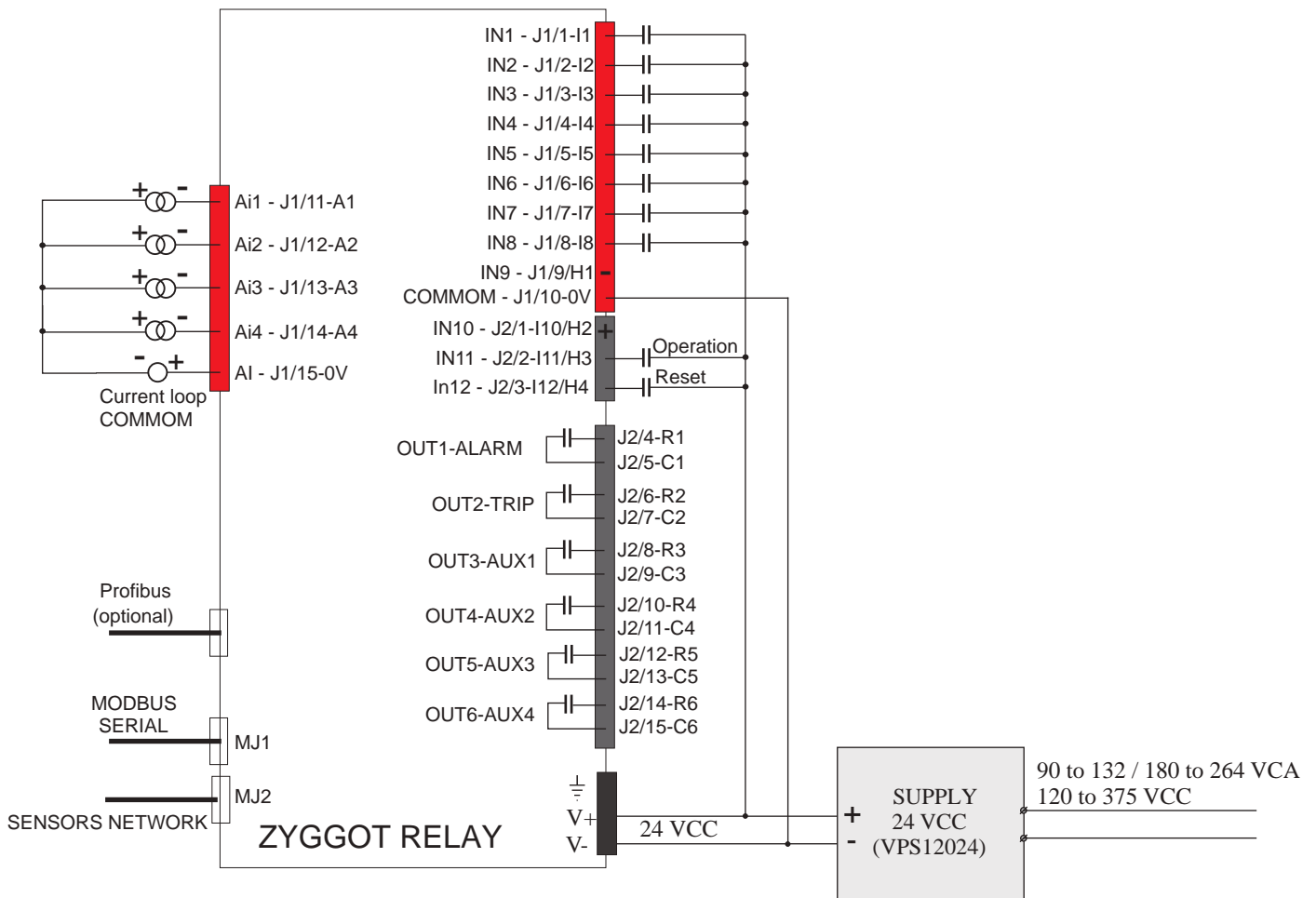

FUNCTION CHART INTEGRITY TEST OVERLAYS



PROTECTIONS AND FUNCTIONS

ANSI	DESCRIPTION	TRIP	ALARM	Monitor
94	8 x Assignable External	<input checked="" type="checkbox"/>	<input checked="" type="checkbox"/>	<input type="checkbox"/>
49	125 Target Overtemperature	<input checked="" type="checkbox"/>	<input checked="" type="checkbox"/>	<input type="checkbox"/>
49	125 Case / Air Overtemp.	<input checked="" type="checkbox"/>	<input checked="" type="checkbox"/>	<input type="checkbox"/>
48	Trip / Incomplete Sequence	<input checked="" type="checkbox"/>	<input type="checkbox"/>	<input type="checkbox"/>
30	Anunciator w/ Time Stamp	<input type="checkbox"/>	<input type="checkbox"/>	<input checked="" type="checkbox"/>
	Event Recorder - 120 Tags	<input type="checkbox"/>	<input type="checkbox"/>	<input checked="" type="checkbox"/>
	Readings 4 External Analog Signal	<input checked="" type="checkbox"/>	<input checked="" type="checkbox"/>	<input checked="" type="checkbox"/>
	Readings - 125 Target °C	<input type="checkbox"/>	<input type="checkbox"/>	<input checked="" type="checkbox"/>
	Readings - 125 Case / Air °C	<input type="checkbox"/>	<input type="checkbox"/>	<input checked="" type="checkbox"/>
	Trendings - Real time curves	<input type="checkbox"/>	<input type="checkbox"/>	<input checked="" type="checkbox"/>

SYSTEM INTEGRITY TEST

Once the system is installed, its integrity can be verified, through a flashing function command or rear LED of each sensor. . Enter in the menu screen "Flash sensors led". In Relay VZX. Press the K9 key; in Relay VZT. Press the K4 key. Insert Sensor = "0" (all LEDs of the sensors should flash at command "ON" and stop flashing at command "OFF"). Enter the number of each sensor, from 1 to 125 and the command "On" only it will flash.

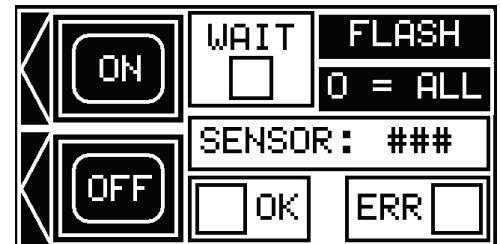

OVERLAY RELAY VZX



OVERLAY RELAY VZT



TECHNICAL SPECIFICATIONS VZX AND VZT MODELS



ZYGGOT Specifications		
Relay General Specifications (for all models)	Models VZX	Models VZT
Required Supply Voltage	24 VDC	24 VDC
Required Power	130 mA @ 24 VDC	130 mA @ 24 VDC
Required Power (Inrush)	30 A for 1 ms @ 24 VDC	30 A for 1 ms @ 24 VDC
Primary Power Range	10 – 30 VDC	10 – 30 VDC
Relative Humidity	5 to 95% Non-condensing	5 to 95% Non-condensing
Operating Temperature	0° to 50° Celsius	0° to 50° Celsius
Terminal Type	Screw Type, 5 mm Removable	Screw Type, 5 mm Removable
Weight	12 oz. (340.19 g)	12 oz. (340.19 g)
Dimensions (mm)	96H x 96W x 57,5D	96H x 96W x 57,5D
Dimensions PROFIBUS (mm)	96H x 96W x 68D	96H x 96W x 68D
Display	2 color graphical LCD	3.5" LCD Graphical 2 Color Touch Screen
User Keys	20	5
Protocols Supported	Modbus RTU, PROFIBUS-DP*	Modbus RTU, PROFIBUS-DP*
Serial Ports	2 RS232 / RS485	2 RS232 / RS485
CE	Compliant	Compliant

* Note: For relays with PROFIBUS-DP communication utilize the codes: VZX/B1/U/P or VZT/B1/U/P

REAR JUNCTION BOX (ZXT-2)

ZYGGOT Specifications	
General Specifications	Model ZXT-2
Dimensions (mm)	86,8H x 86,8W x 41,5D
Required Supply Voltage	24 VDC
Max. Power	2,5 A @ 24 VDC / 60W

PROFIBUS DP OPTION

Table 1 – Specifications						
Software Protocol	DPV0					
Hardware Interface	RS-485					
Power	100mA at 5V					
Transmission Rate	9.6K – 12M bits/second					
Data Access	Cyclic Polling					
Device Identity	Specific ID number for each device					
Data Transfer Size	Upto 246 bytes of Input and 246 bytes of Output					
Supporting Profibus DP	All variants of VZX and VZT Tubular Sensors System					
Cable Length	Baud Rate (Kbits/sec)	93.75	187.5	500	1500	12000
	Length (meters)	1200	1000	400	200	100

TECHNICAL SPECIFICATIONS VZX AND VZT MODELS



ZYGGOT Relays Specifications (Models VZX and VZT)	
Digital DC Inputs	
Inputs per Module	12
Commons per Module	1
Input Voltage Range	10 VDC to 30 VDC
Absolute Max. Voltage	35 VDC Max.
Nominal Input Impedance	10 kΩ
Upper Threshold Current	0.8 / -1.6 mA
Lower Threshold Current	0.3 / -2.1 mA
Max Upper Threshold	8 VDC
Min Lower Threshold	3 VDC
OFF to ON Response	1 ms
ON to OFF Response	1 ms
Isolation	1000 VAC

PowerSupply (VPS12024)	
Rated Input Voltage	115/230 (auto select)
Input Voltage Max. Range	90-132 / 180-264 VAC 120-375 VDC
Output Power	120W
Output Voltage	24 VDC
Output Current	5 A
Efficiency	84% (min) 86% (typical)
Dimensions (mm)	124,5H x 64W x 116,6D

ZYGGOT Relays Specifications (Models VZX and VZT)	
Digital Relay Outputs	
Type	Relay - Dry contact
Outputs per Module	6 NO Relays
Commons per Module	6
Max. Output	3A at 250 VAC, resistive
Max. Total Current	5 A continuous
Max. Output Voltage	275VAC / 30VDC / 125VDC
Min. Output Voltage	-
Max. Switched Power	1250VA / 150W / 50W
Contact Isolation to ground	1000 VAC
Max. Voltage Drop at Rated Current	0.5 V
Max. Inrush Current	-
Expected Life	No load: 5,000,000 Rated load: 100,000
Max. Switching Rate	300 CPM at no load 20 CPM at rated load

ZYGGOT Specifications	
Temperature Sensors (No Contact)	
Tightening	2 Screws
Power Supply Range	12 - 24 VDC
Maximum measurement range (distance from sensor to target)	10 m
Temperature Ranges	0 - 300 °C
Sensor Measurement Angles	7°
Sensor Transmission types	Shielded Cable
Temperature accuracy	+/- 2.5%
Temperature Resolution	1 °C
Pointing	Removable Laser Pointing Device
Max. Sensors per Relay	125
CE	Compliant
Required Power	4,5 mA @ 24 VDC

TECHNICAL SPECIFICATIONS

VZX MODELS OF 96 X 96MM WITH LCD DISPLAY



POWER SUPPLY

Signal Pin	Description
V+	Input power supply voltage
V-	Input power supply ground
Gnd	Frame Ground

GENERAL CHARACTERISTICS

- Graphical LCD Screen w/ Backlight.
- 24 VDC
- RS-232 / RS-485 Serial Ports.
- Integrated Bezel.
- Real-Time Clock.
- Flash Memory for easy field upgrades.
- 20 Function Keys.

Characteristics

Display Type (LCD with backlight):	Monochrome
Display Size:	3.78"W x 3.78"H (96x96mm)
Display Screen Dimensions:	1.97"W x 1.14"H (50x29mm)
Functions Keys:	20
Number of Colors:	2
Power Steady State Current:	130mA @ 24VDC
Inrush Current:	30A @ 24VDC for 1ms.
Height:	3.78" (96.0 mm)
Width:	3.78" (96.0 mm)
Mounting Depth:	2.264" (57.5 mm)
Weight	12 oz (340.19 g)
Keypad Material:	Lexan HP92 by GE Plastics.
Protocols supported Serial Ports:	Modbus Slave, and ASCII Read and Write
Serial Ports:	2 RS-232 / RS-485 Ports.
Temperature & Humidity:	32 - 122°F (0 - 50°C),
5 to 95% Non-condensing	
UL / CE	Compliant

MJ 1 (PORT 1)

PIN	SIGNAL
1	RX+ / TX+
2	RX- / TX-
3	CTS
4	RTS
5	+5V / 60 mA max
6	0 V
7	RXD
8	TXD
Output Power Supply Max 150 mA	

MJ 1 (PORT 1) MODULAR JACK

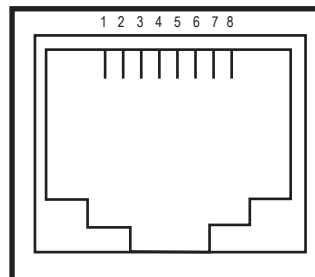

TECHNICAL SPECIFICATIONS

VZT MODELS OF 96 X 96MM WITH TOUCH SCREEN LCD DISPLAY



POWER SUPPLY

Signal Pin	Description
V+	Input power supply voltage
V-	Input power supply ground
Gnd	Frame Ground

GENERAL CHARACTERISTICS

- Graphical LCD Screen w/ Backlight.
- 24 VDC
- RS-232 / RS-485 Serial Ports.
- Integrated Bezel.
- Real-Time Clock.
- Flash Memory for easy field upgrades.
- 20 Function Keys.

Characteristics

Display Type (LCD with backlight):	Monochrome Touch Screen
Display Size:	3.78"W x 3.78"H (96x96mm)
Display Screen Dimensions:	2.82"W x 2.03"H (71,6 x 51,4mm)
Functions Keys:	5
Number of Colors:	2
Power Steady State Current:	130mA @ 24VDC
Inrush Current:	30A @ 24VDC for 1ms.
Height:	3.78" (96.0 mm)
Width:	3.78" (96.0 mm)
Mounting Depth:	2.264" (57.5 mm)
Weight	12 oz (340.19 g)
Keypad Material:	Lexan HP92 by GE Plastics.
Protocols supported Serial Ports:	Modbus Slave, and ASCII Read and Write
Serial Ports:	2 RS-232 / RS-485 Ports.
Temperature & Humidity:	32 - 122°F (0 - 50°C),
5 to 95% Non-condensing	
UL / CE	Compliant

MJ 1 (PORT 1)	
PIN	SIGNAL
1	RX+ / TX+
2	RX- / TX -
3	CTS
4	RTS
5	+5V / 60 mA max
6	0 V
7	RXD
8	TXD
Output Power Supply Max 150 mA	

MJ 1 (PORT 1) MODULAR JACK

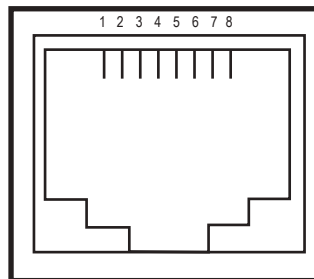

VZT MODELS OF 96 X 96MM WITH TOUCH SCREEN LCD DISPLAY

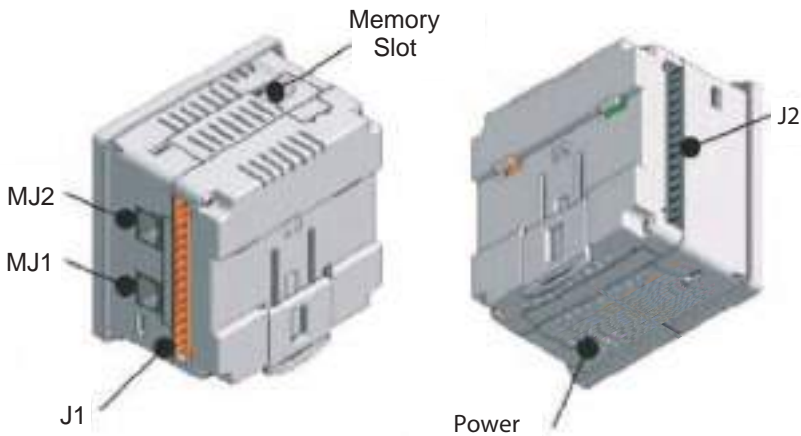

Standard Model (VZX and VZT)

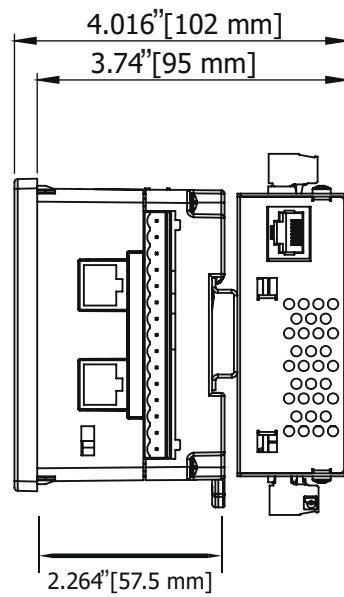

VZX Model

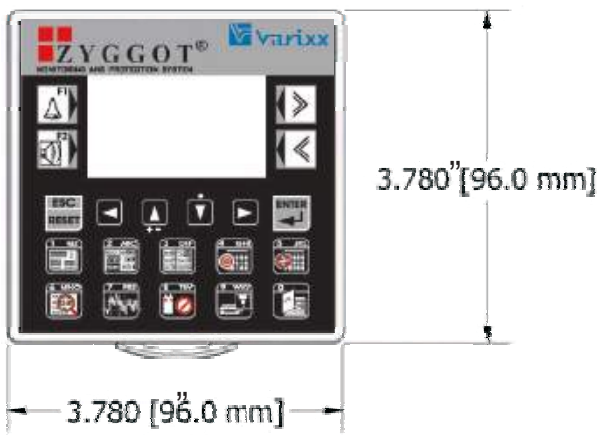

PROFIBUS-DP Model (VZX and VZT)

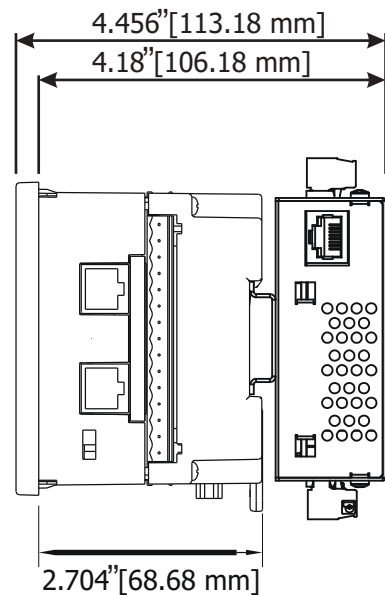

VZT Model

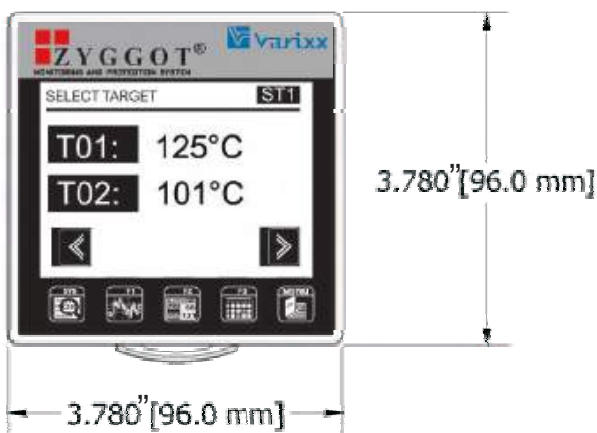

DISPLAY MANUAL (VZX AND VZT MODELS)



> TARG:	83,5 °C
>AIR:	25,4 °C
OK S: 50	NR S: 0
FA <input type="checkbox"/>	AIR <input type="checkbox"/>
TA <input type="checkbox"/>	NR <input type="checkbox"/>
AL <input type="checkbox"/>	TR <input type="checkbox"/>
1	

SELECT TARGET		ST 5
T 101:	83,5 °C	
T120:	25,4 °C	

MAIN DISPLAYS

There are 12 screens selected by the navigation keys («,») showing dozens of information as Maximum target and air temperature, Number of responding sensors, Total alarms, Total trips, Summary of active fails, Modbus Status, Profibus Status, Network Status of the sensors, inputs and outputs Status, digital, and Status of the sensors groups.

DISPLAYS OF SELECTED SENSORS

There are 20 displays showing 20 target temperature and 20 selectable air temperatures. Sensors indexes are freely inserted by the front keypad, changing the indication. The user can therefore program the main sensors for the indication in these easy-to-read displays. In these displays, the alarm and trip conditions are indicated for each selected point, flashing the index and reading respectively.

TARGET ALARM			TA1
T 001 <input type="checkbox"/>	T 006 <input type="checkbox"/>	T 011 <input type="checkbox"/>	
T 002 <input type="checkbox"/>	T 007 <input type="checkbox"/>	T 012 <input type="checkbox"/>	
T 003 <input type="checkbox"/>	T 008 <input type="checkbox"/>	T 013 <input type="checkbox"/>	
T 004 <input type="checkbox"/>	T 009 <input type="checkbox"/>	T 014 <input type="checkbox"/>	
T 005 <input type="checkbox"/>	T 010 <input type="checkbox"/>	T 015 <input type="checkbox"/>	

AIR ALARM			AA1
A 001 <input type="checkbox"/>	A 006 <input type="checkbox"/>	A 011 <input type="checkbox"/>	
A 002 <input type="checkbox"/>	A 007 <input type="checkbox"/>	A 012 <input type="checkbox"/>	
A 003 <input type="checkbox"/>	A 008 <input type="checkbox"/>	A 013 <input type="checkbox"/>	
A 004 <input type="checkbox"/>	A 009 <input type="checkbox"/>	A 014 <input type="checkbox"/>	
A 005 <input type="checkbox"/>	A 010 <input type="checkbox"/>	A 015 <input type="checkbox"/>	

TARGET TRIP			TT1
T 001 <input type="checkbox"/>	T 006 <input type="checkbox"/>	T 011 <input type="checkbox"/>	
T 002 <input type="checkbox"/>	T 007 <input type="checkbox"/>	T 012 <input type="checkbox"/>	
T 003 <input type="checkbox"/>	T 008 <input type="checkbox"/>	T 013 <input type="checkbox"/>	
T 004 <input type="checkbox"/>	T 009 <input type="checkbox"/>	T 014 <input type="checkbox"/>	
T 005 <input type="checkbox"/>	T 010 <input type="checkbox"/>	T 015 <input type="checkbox"/>	

AIR TRIP			AT1
A 001 <input type="checkbox"/>	A 006 <input type="checkbox"/>	A 011 <input type="checkbox"/>	
A 002 <input type="checkbox"/>	A 007 <input type="checkbox"/>	A 012 <input type="checkbox"/>	
A 003 <input type="checkbox"/>	A 008 <input type="checkbox"/>	A 013 <input type="checkbox"/>	
A 004 <input type="checkbox"/>	A 009 <input type="checkbox"/>	A 014 <input type="checkbox"/>	
A 005 <input type="checkbox"/>	A 010 <input type="checkbox"/>	A 015 <input type="checkbox"/>	

DISPLAYS OF ALARM INDICATIONS AND TRIP FOR TARGETS

There are screens showing all alarm indications and trips for existing targets. When the level has been reached, the square of the right becomes black.

ALARM AND TRIP DISPLAYS FOR TARGETS

These screens show show all alarm and trips indications to the existing sensors, which in reality is the temperature of the surrounding air. When the level has been reached, the square of the right becomes black.

DISPLAY MANUAL (VZX AND VZT MODELS)



TEMPERATURE DISPLAY

They are screens that show all system temperatures in degrees Centigrade or Fahrenheit.

T001:	48	TARGET °C	T01
T002:	32	T004:	128
T003:	64	T005:	57

A001:	48	AIR °C	T01
A002:	32	A004:	128
A003:	64	A005:	57

SENSORS STATUS DISPLAY

They are screens that show all the sensors. If the sensor is not responding, the right square becomes black.

NOT RESPONDING			NR1
S 001	<input type="checkbox"/>	S 006	<input type="checkbox"/>
S 002	<input type="checkbox"/>	S 007	<input type="checkbox"/>
S 003	<input type="checkbox"/>	S 008	<input type="checkbox"/>
S 004	<input type="checkbox"/>	S 009	<input type="checkbox"/>
S 005	<input type="checkbox"/>	S 010	<input type="checkbox"/>
S 011	<input type="checkbox"/>	S 012	<input type="checkbox"/>
S 013	<input type="checkbox"/>	S 014	<input type="checkbox"/>
S 015	<input type="checkbox"/>	S 015	<input type="checkbox"/>

ALARMS/ACTIVE FAILS DISPLAY

There are dozens of screens that show all the possible faults monitored by the system.

ACTIVE FAILS	AF1
TARGET TRIP	<input type="checkbox"/>
TARGET ALARM	<input type="checkbox"/>
CASE / AIR TRIP	<input type="checkbox"/>
CASE / AIR ALARM	<input type="checkbox"/>

ACTIVE FAILS	AF2
EXTERNAL 1:	XXXXXX <input type="checkbox"/>
EXTERNAL 2:	XXXXXX <input type="checkbox"/>
EXTERNAL 3:	XXXXXX <input type="checkbox"/>
EXTERNAL 4:	XXXXXX <input type="checkbox"/>

ACTIVE FAILS	AF5
ANALOG 1 TRIP:	XXXXXXXXXX <input type="checkbox"/>
ANALOG 2 TRIP:	XXXXXXXXXX <input type="checkbox"/>
ANALOG 3 TRIP:	XXXXXXXXXX <input type="checkbox"/>
ANALOG 4 TRIP:	XXXXXXXXXX <input type="checkbox"/>

SUMMARY AND INFORMATION LOG DISPLAY

There are several screens that present information such as the total life of the relay, plant and assembly location information, Alarms/Fails and Alarms/Active Fails information log.



DISPLAY MANUAL (VZX AND VZT MODELS)

DISPLAYS OF TRENDING

There are several screens that show real-time curves of monitored variables, such as temperature and analog inputs.

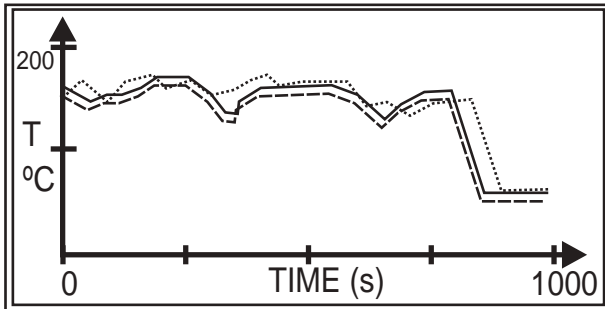

DATA AND PARAMETERS DISPLAY

DATA	TA1
WARN / FAILS	↑
ACTIVE FAILS 1/2	
ACTIVE FAILS 2/2	↓
COMMUNICATION	
DIG INPUTS	
DIG OUTPUTS	
STATISTICS	
INFO	

SUMMARY OF PROGRAMMING AND OPERATION

PROGRAMMING

To enter the programming menu, press the "0" key with the symbol of a menu on the VZX relay or the F4 key with the symbol of a menu on the VZT relay. If the previously entered password is "0", the menu will appear immediately, otherwise enter the correct password to access the menu.

OPERATION

The relays keys may have more than one function. Press once to have access to the first function or series of displays, again for the Second function and a third time in case the key has three functions. This is intuitive and it is possible to observe the screens switching according to each function. Once you are in a group of displays (e.g. "Main Displays" you can browse through all the displays of this group by the navigation keys («,») to left and right. There are special keys to call the alarm display and events display (up to 120 events in the list).

In the following pages we will present the programming display flow for relay VZX and VZT.

FINALIZING THE STARTUP

Once the integrity of the system is checked, end the full programming of the system by the protection relay or by the PC setup program (see manual). Perform multiple readings and check the consistency of the same in relation to temperature of known targets and ambient temperature. Simulate actuations of alarms and trips, reducing the levels of some of the points provisionally to values below the current temperature and analyze the performance of the output contacts, according to the setting made. Also check (if used), the indications of the analog inputs and indications of external digital inputs.

FUNCTION KEYS

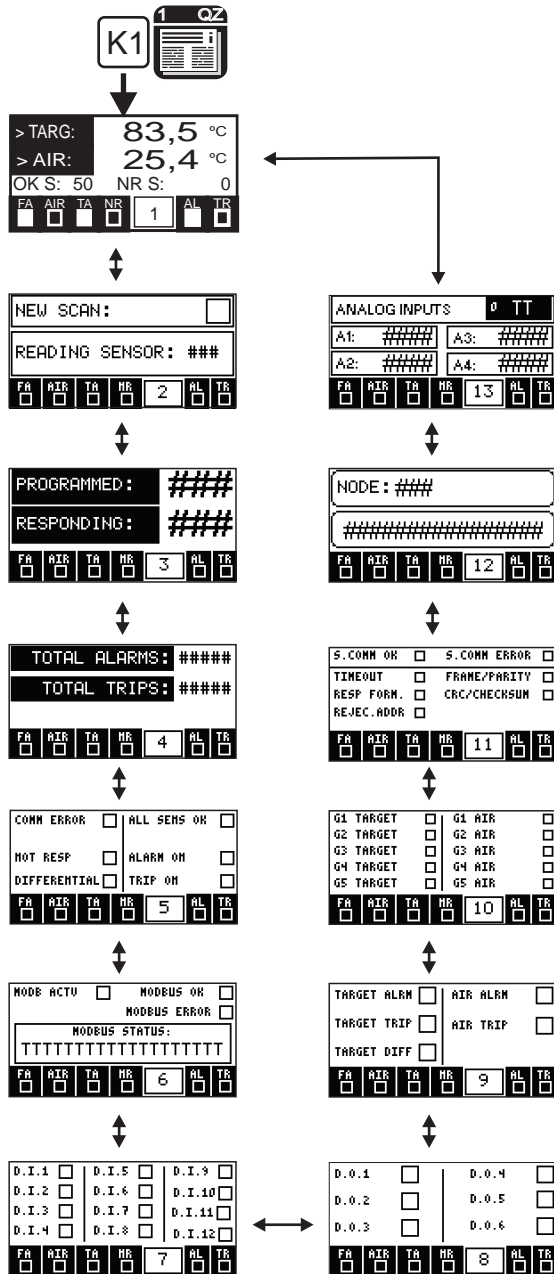

FUNCTION KEYS

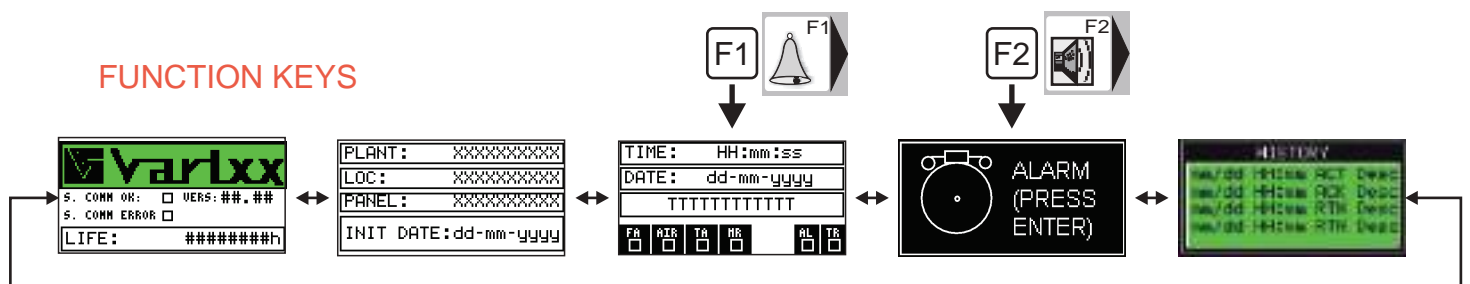

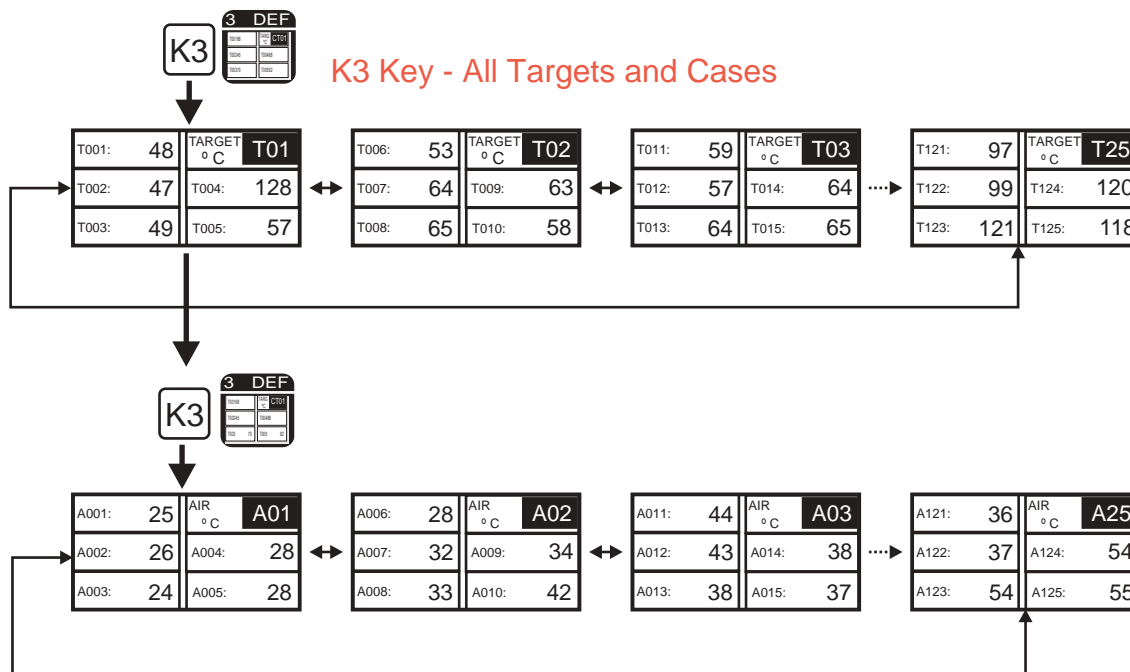
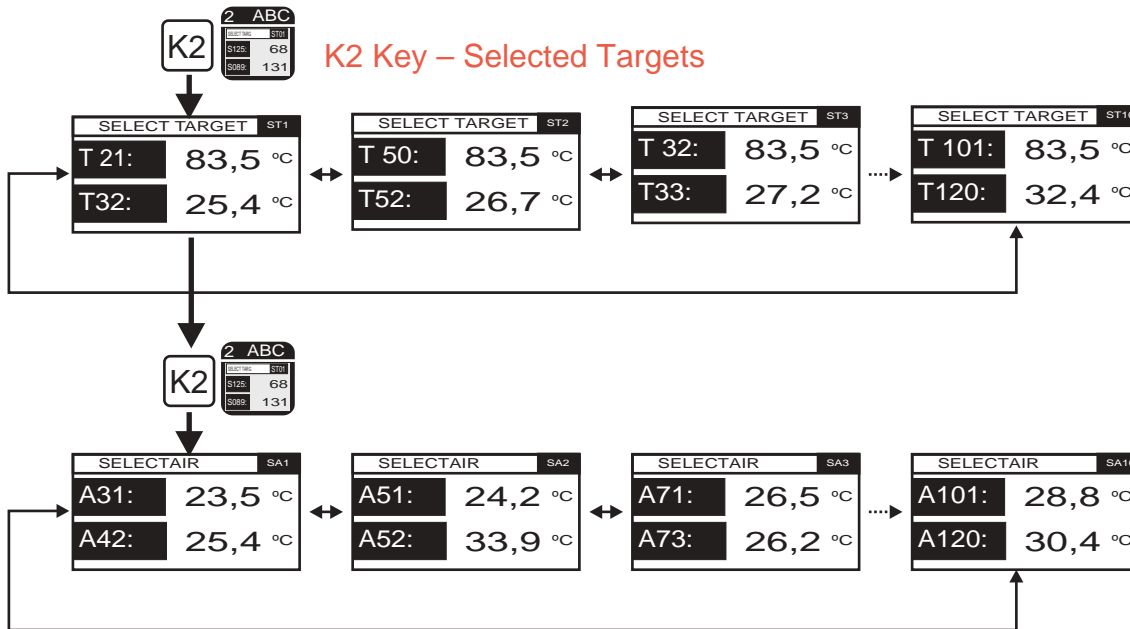

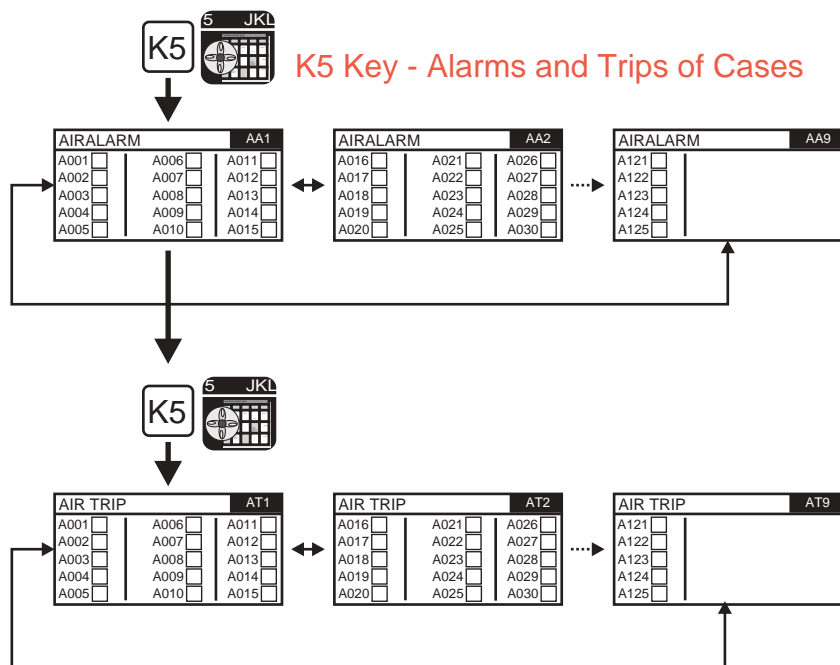
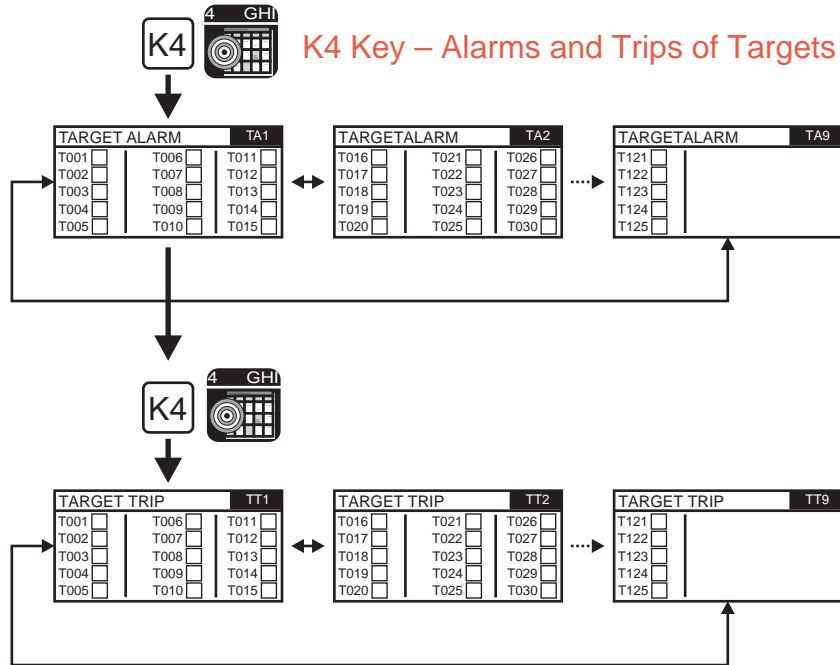

PROGRAMMING DISPLAY FLOW MODEL VZX FUNCTION KEYS



K6 Key – Active Fails and Data

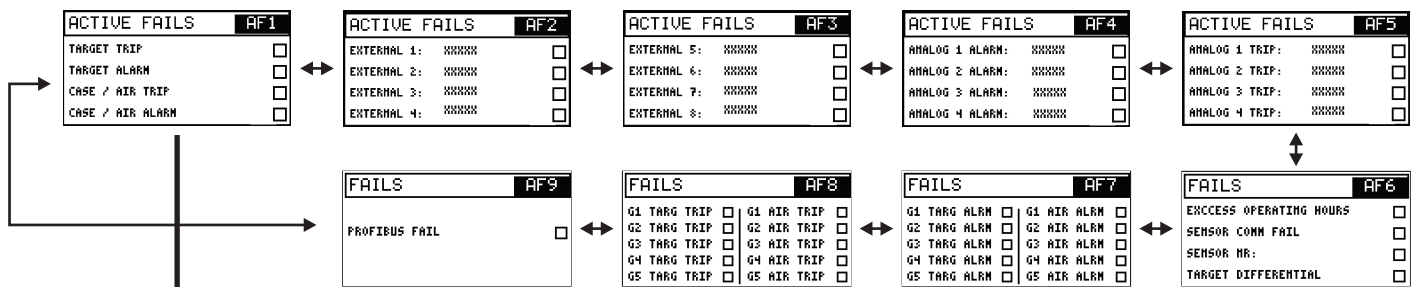

K6 Key - Data and Parameters

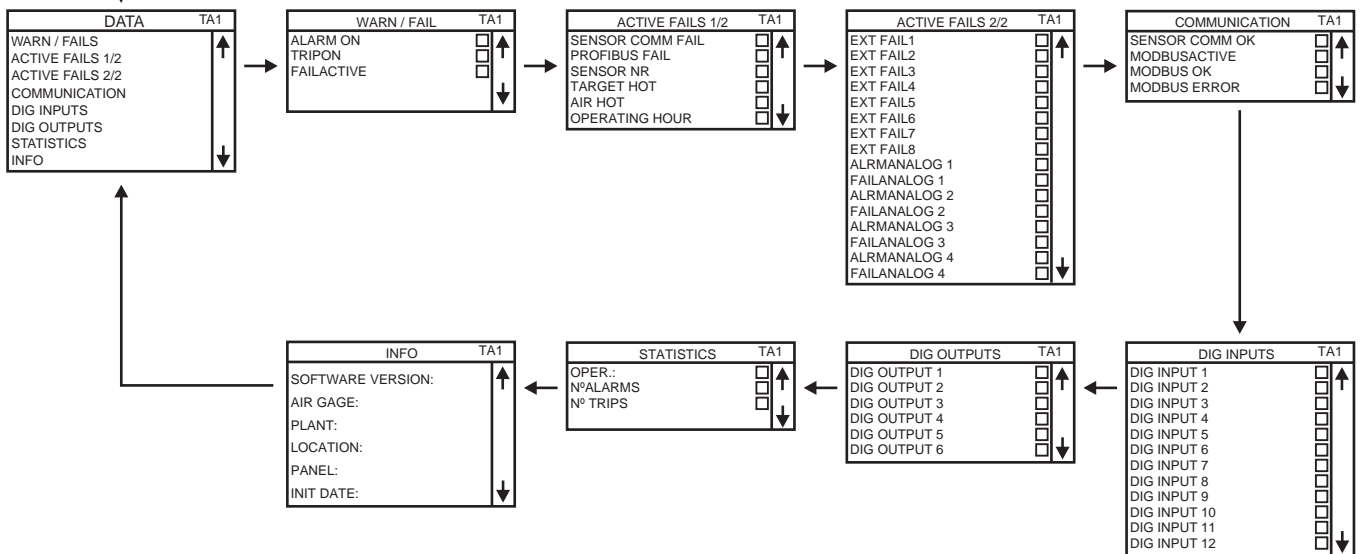

PROGRAMMING DISPLAY FLOW MODEL VZX FUNCTION KEYS



K7 Key - Trendings and Differential

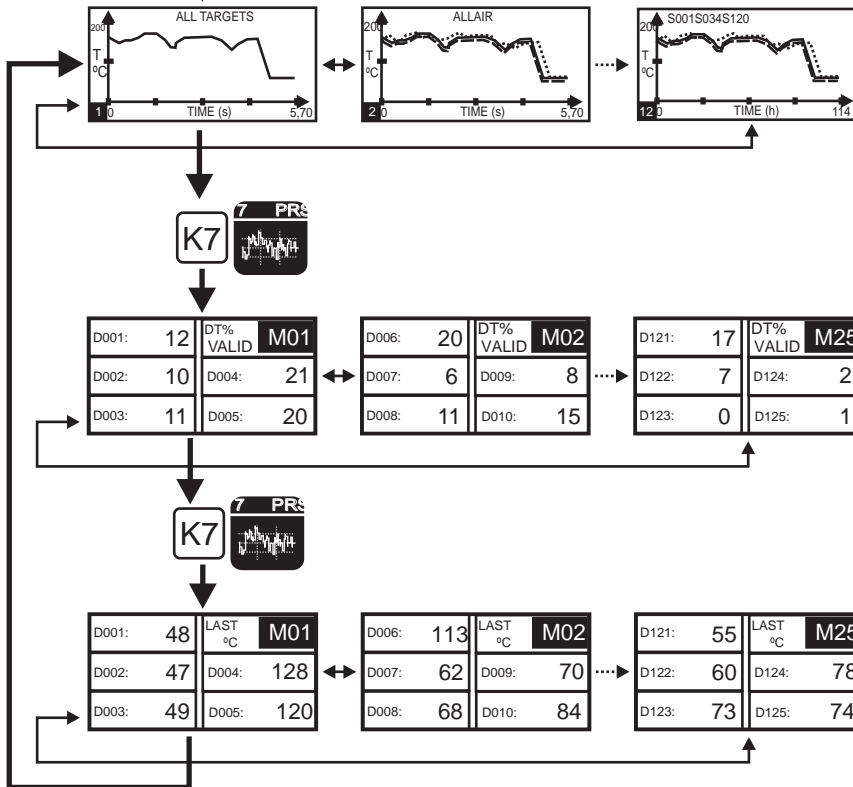

K8 Key - "Not Responding"

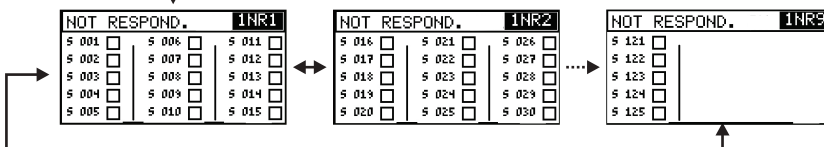

K9 Key - Flash Command

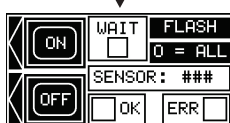

PROGRAMMING DISPLAY FLOW MODEL VZX FUNCTION KEYS



K10 Key - Programming Menu

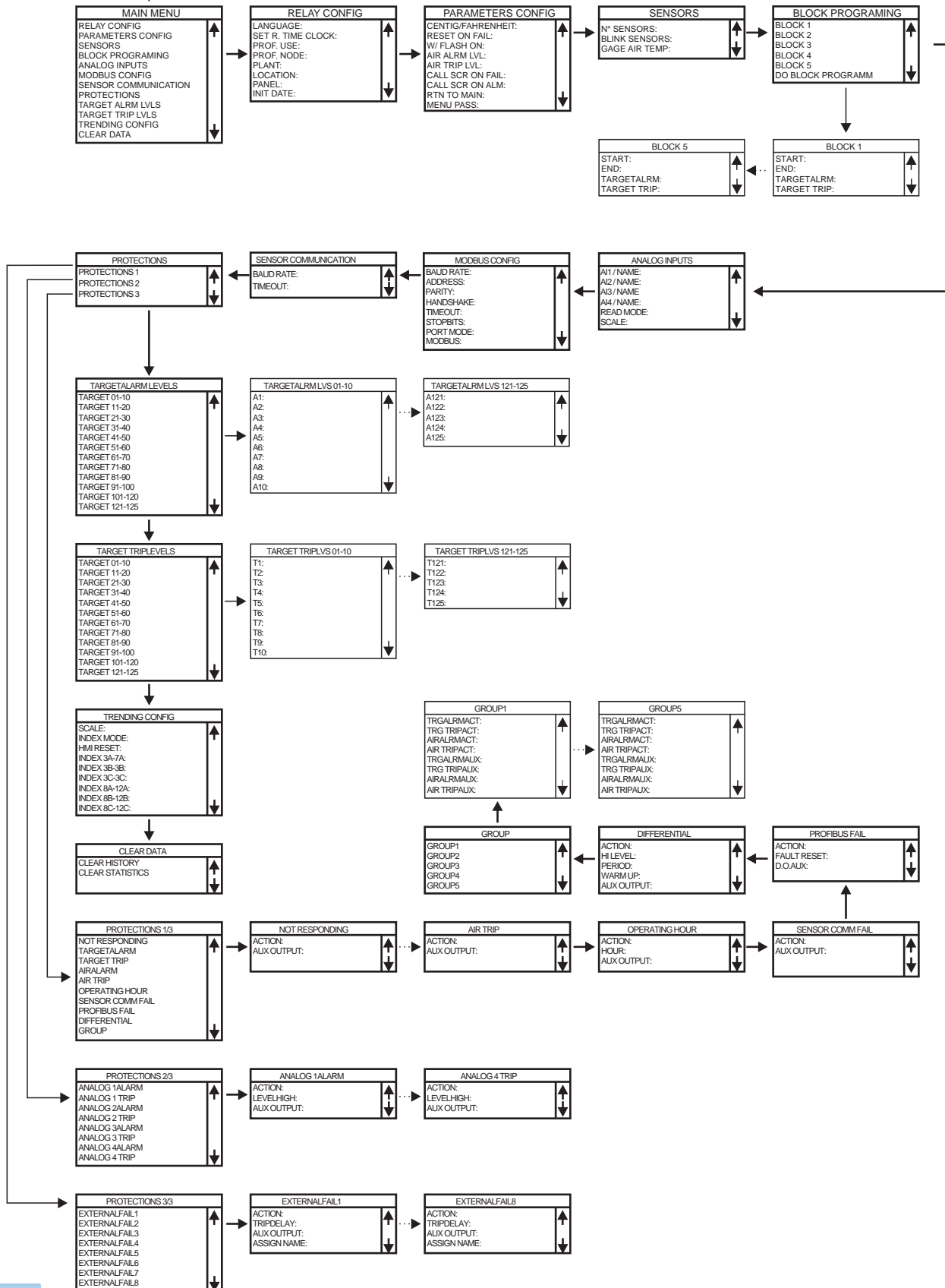

PROGRAMMING DISPLAY FLOW MODEL VZX FUNCTION KEYS



K0 Key - Main Displays

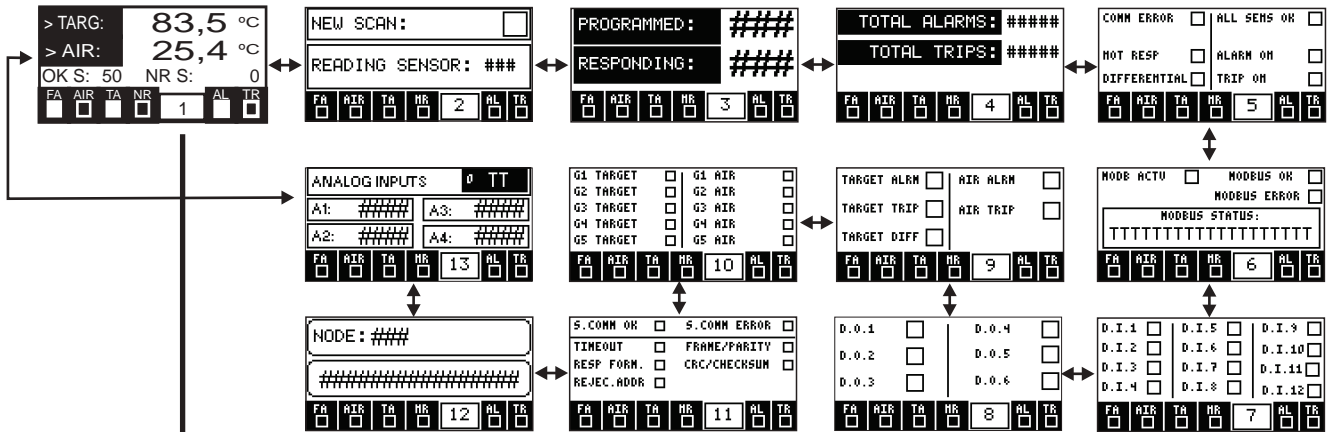

K0 Key - Active Fails and Data

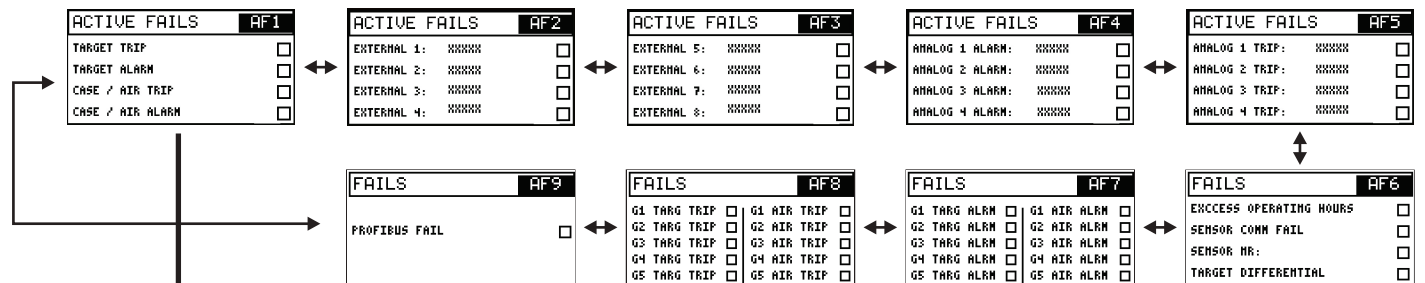

K0 Key - Summary and Information/Data log



PROGRAMMING DISPLAY FLOW MODEL VZT FUNCTION KEYS

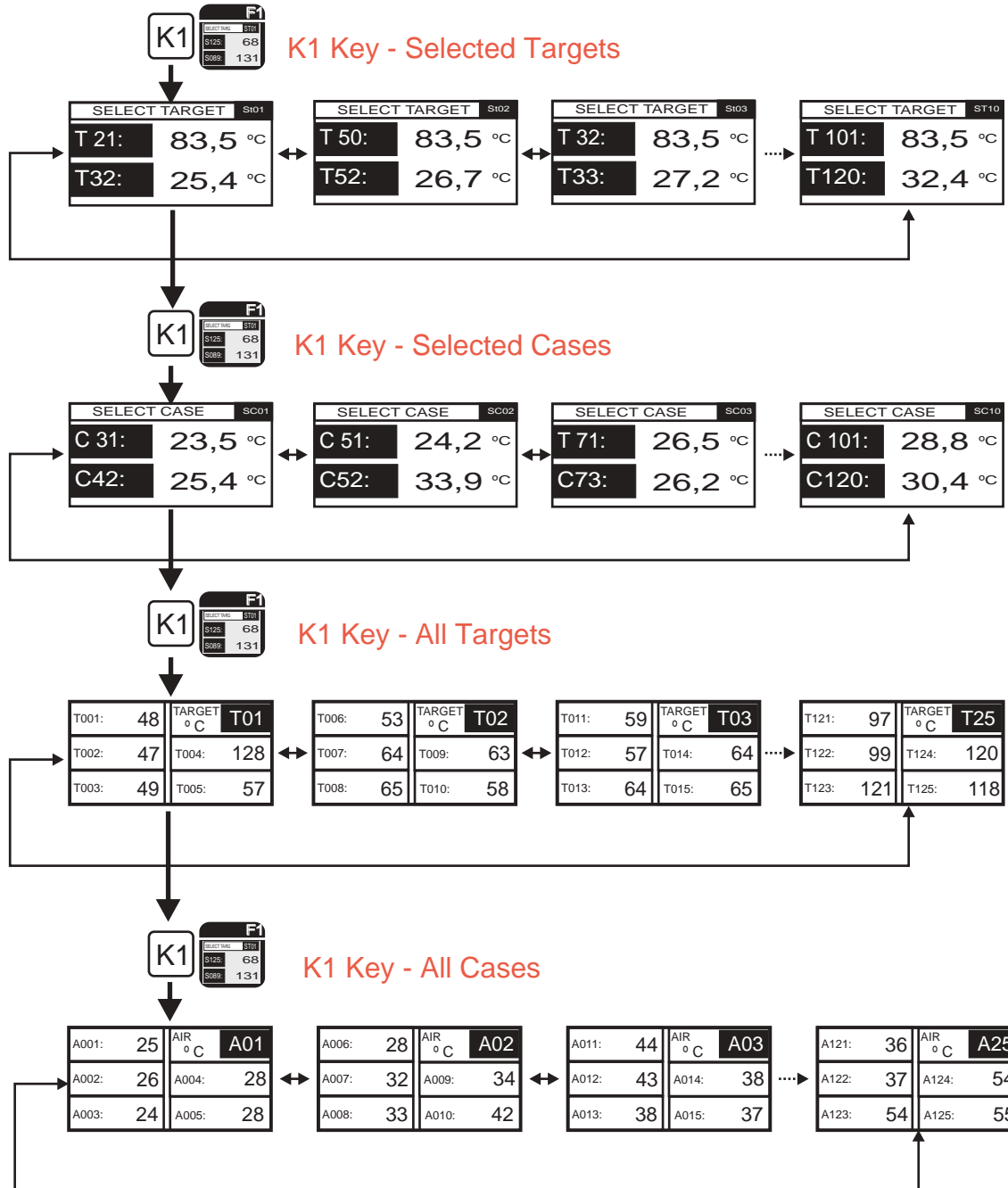

PROGRAMMING DISPLAY FLOWMODEL VZT FUNCTION KEYS

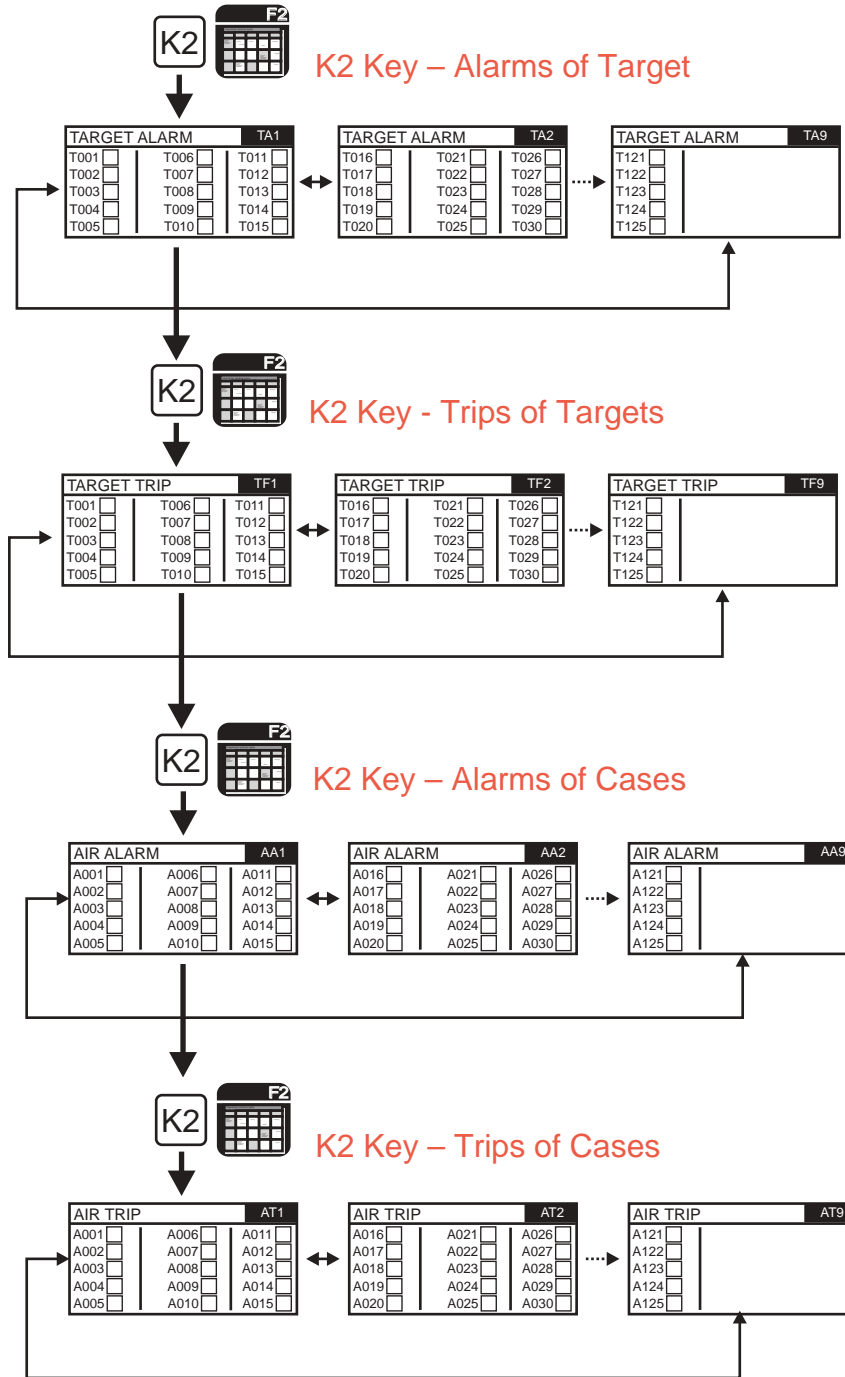

PROGRAMMING DISPLAY FLOW MODEL VZT FUNCTION KEYS

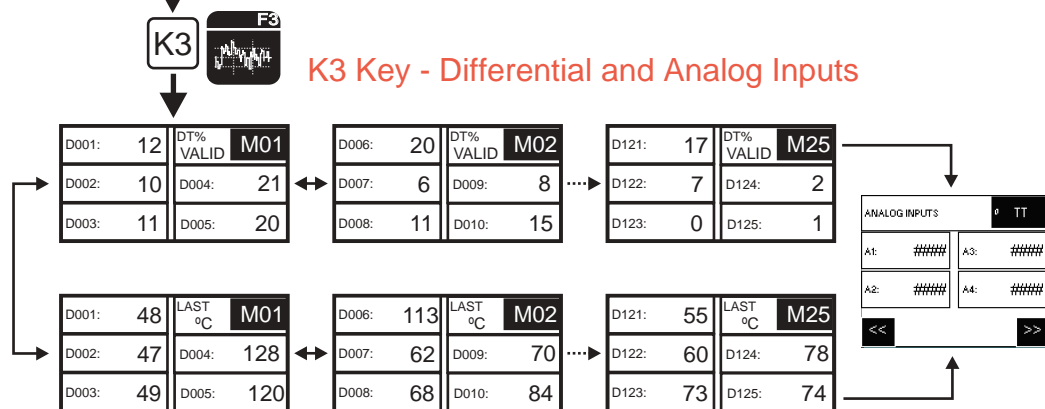
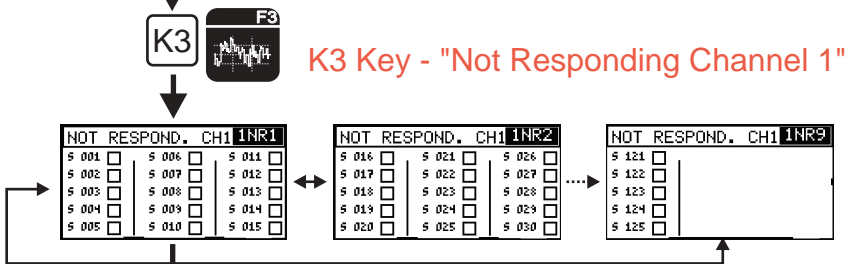
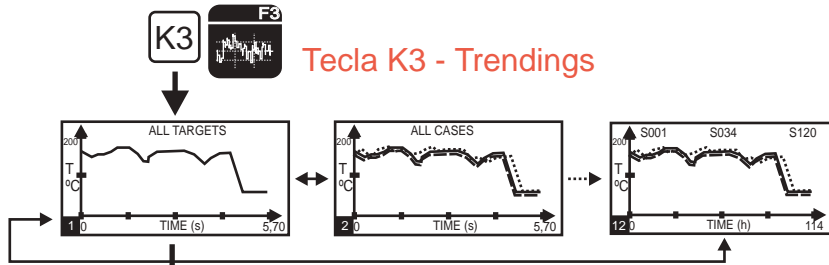

PROGRAMMING DISPLAY FLOW MODEL VZT FUNCTION KEYS

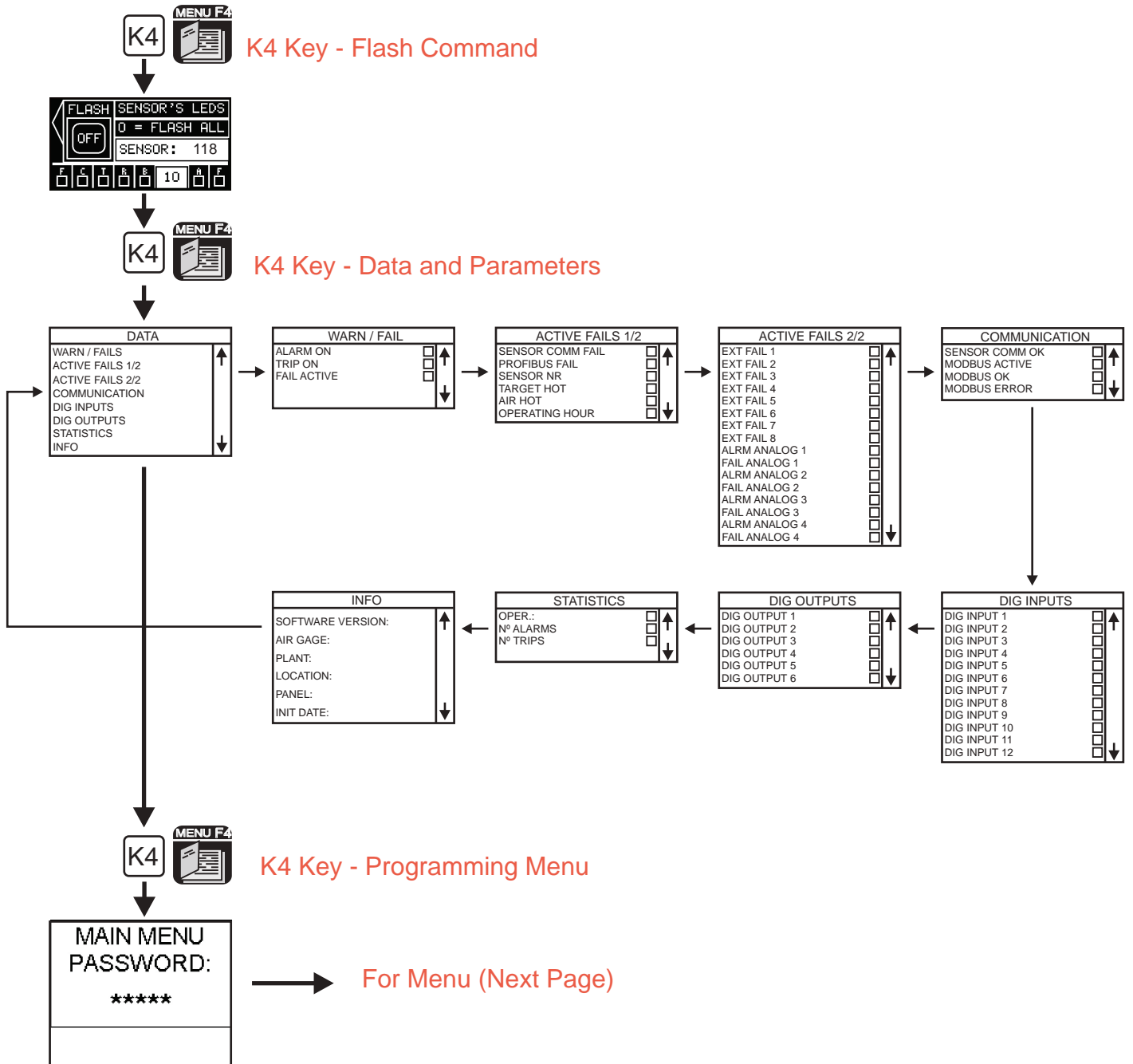

PROGRAMMING DISPLAY FLOW MODEL VZT FUNCTION KEYS



K4 Key - Programming Menu

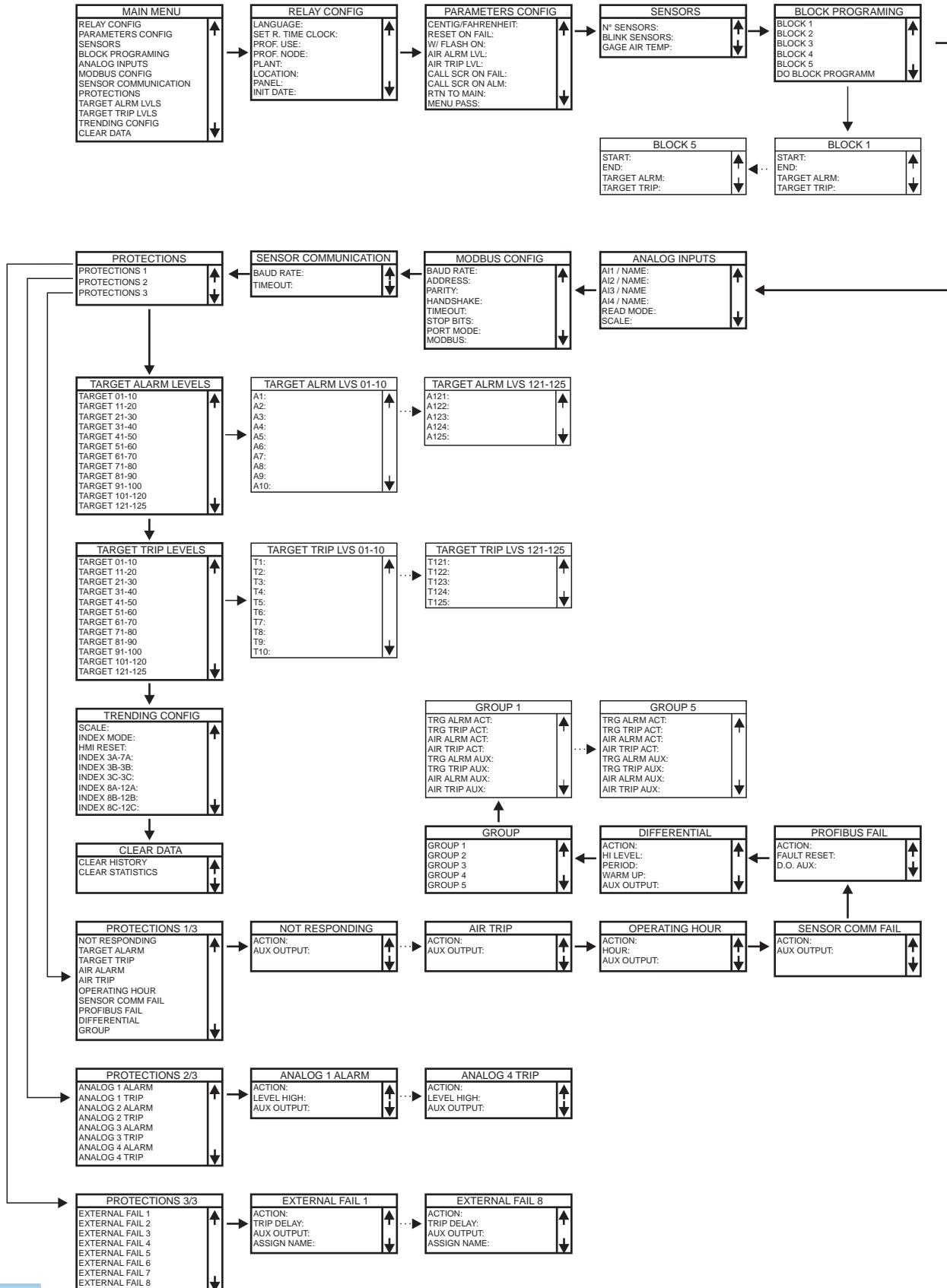

PARAMETERIZATION BY RELAY



Programming Menu – K10 (VZX) OR K4 (VZT) Key

SUBMENU "RELAY CONFIGURATION"

In this menu you must set the parameters for the relay as follows:

- Language: You can choose one of three languages (English, Portuguese and Spanish).
- Set Clock: Enter the current time.
- Prof. Use: Choose between using or not using the Profibus network
- Prof. Node: Set the relay address on the Profibus network. In order to validate the Profibus change, you must restart the relay.
- Plant: Plant name where the system is installed/assembled.
- Location: Plant area where the system is installed.
- Panel: Panel Identification.
- Date In.: Operation start date.

SUBMENU "PARAMETERIZATION CONFIGURATION"

In this menu you should set the parameters related to the system

- Centig/Fahrenheit: Choose the temperature system indication
- Fail reset : If chosen yes, the relay accepts the fails reset even with active fails on, returning to indicate the fails in the next reading.
- Level of Air Alarm: The alarm level for the surrounding air temperature is the same for all system sensors. If exceeded, the alarm output is actuated.
- Level of Air Trip: The trip level for the surrounding air temperatures is the same for all system sensors. If exceeded, the trip output is actuated.
- Fail Screen Call: Once chosen Yes, if a failure occurs the relay calls the alarm display. If chosen No, there will be an indication on LED "FA" from the main display. The operator can call the alarm displays and the failure history log by the F1 key.
- Alarm Screen call: Same actions of the previous item, but if occurs an alarm.
- Returns to Main Screens: Time for automatic return to the main displays (also called with K1 key). Programmable between 0 and 999 s. If programmed 0, does not automatically return to the main display.
- Menu Password: Enter the desired password. If chosen 0000, the menu will be opened without password request.

SUBMENU "SENSORS"

In this menu you must set the parameters related to the system sensor network:

- No. Sensors: Set the number of installed sensors (3-125).
- Flash Sensors: In this display you can command an individual sensor flashes its case LED for integrity check or addressing. Enter the sensor number and confirm. If inserted "0", all the sensors will flash the LED. After 4 seconds the LED stops flashing automatically.
- Air temperature arrow: Adjust the sensor air temperature reading. This operation is optional and must be performed with all sensors at the same ambient temperature. Using this command without knowledge can damage the readings. The sensors come from the factory properly calibrated, so this operation is not necessary.

SUBMENU "BLOCK PROGRAMMING"

In this menu you can set and perform the programming of sequential sensor blocks. They are allowed up to 5 sensors blocks. For each block, you must fill the following parameters:

- Start: First block of the sensor.
- End: Last block of the sensor.
- Alarm Point: Alarm Level.
- Trip Point: Trip Level.

At the end of the definition of the blocks, you must access "Block Program" and confirm the operation. Only after this, the parameters and blocks are set.

SUBMENUS "ANALOG INPUTS"

In this menu you must set the parameters related to the analog inputs 1 to 4:

- EA1 / Name: Input name 1.
- EA2 / Name: Input name 2.
- EA3 / Name: Input name 3.
- EA4 / Name: Input name 4.
- Read mode: % or temperature. If chosen %, the indication will be in percentage of full scale.
- Scale: Full-scale value.

SUBMENU "MODBUS"

In this menu you must set the parameters related to the Modbus communication, if used. The parameters available are:

- Baud Rate: 9600, 19200 or 38400
- Address: 1 to 247
- Parity: None, Odd, Even
- Handshake: None, Xon/Xoff, CTS/RTS, MD/Half Duplex.
- Timeout: Time for timeout error indication (max 1000 s.).
- Stop Bits: 1 or 2
- Port Mode: RS232 or Rs485.
- Modbus: Active or Inactive. If not using, select "Inactive".

SUBMENU "COMMUNICATION SENSOR"

In this menu you must set the parameters related to the communication with sensors:

- Baud Rate: 300, 600, 1200, 2400, 4800, 9600, 19200, 38400, 57600 or 115200
- Timeout: 0,1 to 5,0 s

SUBMENU "ALARM LEVELS POINTS"

In this menu you can individually set the alarm levels for each measuring point:

- T1 to T125: Enter directly with the temperature value.

SUBMENU "TRIP LEVELS POINTS"

In this menu you can individually set the trip levels for each measuring point:

- T1 to T125: Enter directly with the temperature value.

SUBMENU "TRENDING CONFIGURATION"

In this menu you can set the parameters corresponding to the system of "Trending", i.e., the viewing of the temperature curves obtained in real-time.

Scale: Upper limit of temperature for the graphics.

Index Mode: Display or Menu. At "Display", the operator chooses the sensors to be monitored for the curves on the display of "trending". If chosen "Menu", the sensors used in the curves are defined in this submenu. The "Menu" mode inhibits the operator to clean or lose curves already in acquisition.

IHM Reset: If chosen "Yes", is allowed to curves to be cleared or reset holding the RESET key pressed for 3 seconds.

PARAMETERIZATION BY RELAY

Programming Menu – K10 (VZX) OR K4 (VZT) Key

- Index 3A-7A: If chosen Index Mode as "Menu", the number of the inserted sensor here will be used for the curve "A" of the graphics 3 to 7. Each graphic shows three temperatures simultaneously.
- Index 3B-7B: Same as Index 3A-7A for curves "B".
- Index 3C-7C: Same as Index 3A-7A for curved "C".
- Index 8A-12A: If chosen Index Mode as "Menu", the number of the inserted sensor here will be used for the curve "A" of the graphics 8 to 12. Each graphic shows three temperatures simultaneously.
- Index 8B-12B: Same as Index 8A-12A to the curves "B".
- Index 8C-12C: Same as Index 8A to 12A-curves "C".

SUBMENU "CLEAR DATA"

In this menu you can clear the data log of defects and statistics.

- History: Will be presented an identical display of the main display history display of the main displays called by the corresponding icon, but with the option of clean each item or all items. To access these options, press the keys at the right of the display.
- Statistics: In this menu you can clean the statistical data (number of readings, number of alarms and number of trips).

SUBMENU "PROTECTIONS"

The protections menu is divided in three parts. Protections 1 to 3.

Overall, the action taken is programmed in case of failure and the auxiliary relay to be activated. General explanation of the actions:

- Alarm: The alarm relay acts and then occurs indication in the relay. Some protections do not have this action as an option.
- Trip: The alarm relay and the trip relay act and then occurs indication in the relay. Some protections do not have this action as an option.
- Log: The alarm and trip relay do not act. Occurs indication in the relay.
- Nothing: No action is taken. The failure detection is disabled.

In case of any failures, an auxiliary relay can be defined (Relays 3 to 6). The auxiliary relay may be associated with more than one failure. If the action of the failure is NOTHING, the auxiliary relay will not act.

SUBMENU "PROTECTIONS 1/3"

In the first submenu protections are protections related to the variation of temperature, the sensor communication network and communication failures.

Not Responding: Sensors not responding.

- Action: Nothing, Log, Alarm, Trip

- Aux Output: none, 3, 4, 5, 6

Alarm Point: Measuring point reached alarm level.

- Action: Nothing, Log, Alarm

- Aux Output: none, 3, 4, 5, 6

Trip point: Measuring point reached trip level.

- Action: Nothing, Log, Trip

- Aux Output: none, 3, 4, 5, 6

Air Alarm: Surrounding air temperature reached the alarm level.

- Action: Nothing, Log, Alarm

- Aux Output: none, 3, 4, 5, 6

Air Trip: Surrounding air temperature reached the trip level.

- Action: Nothing, Log, Trip

- Aux Output: None, 3, 4, 5, 6

Operating hours: Relay operating time reaches the limit.

- Action: Nothing, Log, Alarm

- Time: 0.00 to 300.00 (x 1000 h)

- Aux Output: none, 3, 4, 5, 6

Failure Communication Sensors: Error in communication with the sensors network.

- Action: Nothing, Log, Alarm

- Aux UX Output: none, 3, 4, 5, 6

Profibus Failure: Failure Profibus communication.

- Action: Nothing, Log, Alarm, Trip

Reset Failure: Manual/Auto. If the fault does not occur, the relay should automatically reset the indication in the relay and output (Auto Mode) or the operator must press the RESET button (Manual Mode)

- Aux Output: none, 3, 4, 5, 6

Differential: The differential failure analyzes the temperature increase (in %) that occurred during the period. If the temperature increase is higher than the value set at "High Level", set action will be executed the. The relay has a digital input called "Operation", which indicates the energizing of the panel and the start of the time count.

To avoid variation due to the initial temperature increase that exists when starting the operation panel, a time of "Heating" can be set, in which a differential failure waits until the panel reaches its normal working temperature. After the heating period, the sensor temperature value is stored and used as a reference for the calculation increase in the period. At the end of the period, a new temperature value is stored and used as reference for the next period.

- Action: Nothing, Log, Alarm, Trip

- High Level: 0 to 200%

- Period: 0 to 10000 h

- Heating : 0 to 100 h

- Aux Output: none, 3, 4, 5, 6

The percentage indications of the increase measured to each target are presented with double drive of the K7 key (VZX relay) or triple drive of the K3 key (VZT relay). The reference temperature for the percentage calculation can be verified through the triple drive of the key K7 (VZX relay); for the VZT relay, the reference values are along with the percentage values, use the navigation keys to reach the reference values.

EXAMPLE: Period: 30 days (720 h), High level: 20%. First measurement for one of the targets = 50 °C. One month after measured for the same target 55°C. The increase was therefore 10%, no failure occurring. The temperature of 55 °C becomes the new reference. In the following month, the measured temperature = 70 °C, so the Delta T = $((70-55)/55)*100=27\%$ and thus there will be the acting.

Group: For each group the following settings are available.

- Action Alarm Point: Nothing, Log, Alarm

- Action Trip Point: Nothing, Log, Trip

- Action Air Alarm: Nothing, Log, Alarm

- Action Air Trip: Nothing, Log, Trip

- Aux Alarm Point: Nothing, 3, 4, 5, 6

- Aux Trip Point: Nothing, 3, 4, 5, 6

- Aux Air Alarm: Nothing, 3, 4, 5, 6

- Aux Air Trip: Nothing, 3, 4, 5, 6

PARAMETERIZATION BY RELAY

Programming Menu – K10 (VZX) OR K4 (VZT) Key

SUBMENU “PROTECTIONS 2/3”

This submenu treats the protection related with the analog inputs. For each input, the alarm level is set, trip level and action to take in each one.

Analog 1 Alarm: Set alarm level and action to be taken for analog input 1.

- Action: Nothing, Log, Alarm
- High Level: 0 to 100%
- Aux Output: none, 3, 4, 5, 6

Analog 1 Trip: Set trip level and action to be taken for analog input 1.

- Action: Nothing, Log, Alarm
- High Level: 0 to 100%
- Aux Output: none, 3, 4, 5, 6

Analog 2 Alarm: Set alarm level and action to be taken for analog input 2.

- Action: Nothing, Log, Alarm
- High Level: 0 to 100%
- Aux Output: none, 3, 4, 5, 6

Analog 2 Trip: Set trip level and action to be taken for analog input 2.

- Action: Nothing, Log, Alarm
- High Level: 0 to 100%
- Aux Output: none, 3, 4, 5, 6

Analog 3 Alarm: Set alarm level and action to be taken for analog input 3.

- Action: Nothing, Log, Alarm
- High Level: 0 to 100%
- Aux Output: none, 3, 4, 5, 6

Analog 3 Trip: Set trip level and action to be taken for analog input 3.

- Action: Nothing, Log, Alarm
- High Level: 0 to 100%
- Aux Output: none, 3, 4, 5, 6

Analog 4 Alarm: Set alarm level and action to be taken for analog input 4.

- Action: Nothing, Log, Alarm
- High Level: 0 to 100%
- Aux Output: none, 3, 4, 5, 6

Analog 4 Trip: Set trip level and action to be taken for analog input 4.

- Action: Nothing, Log, Alarm
- High Level: 0 to 100%
- Aux Output: none, 3, 4, 5, 6

SUBMENU “PROTECTIONS 3/3”

This submenu defines the actions for the digital inputs. For each of the 8 failures digital inputs, can define the generated action, an auxiliary output, the delay time for detection of drive input and a name for the input.

External Failure 1

- Action: Nothing, Log, Alarm, Trip
- Trip Delay: 0 to 99,9 s
- Aux Output: Nothing, 3, 4, 5, 6.
- Name: Up to 5 characters

External Failure 2

- Action: Nothing, Log, Alarm, Trip
- Trip Delay: 0 to 99,9 s
- Aux Output: Nothing, 3, 4, 5, 6.
- Name: Up to 5 characters

External Failure 3

- Action: Nothing, Log, Alarm, Trip
- Trip Delay: 0 to 99,9 s
- Aux Output: Nothing, 3, 4, 5, 6.
- Name: Up to 5 characters

External Failure 4

- Action: Nothing, Log, Alarm, Trip
- Trip Delay: 0 to 99,9 s
- Aux Output: Nothing, 3, 4, 5, 6.
- Name: Up to 5 characters

External Failure 5

- Action: Nothing, Log, Alarm, Trip
- Trip Delay: 0 to 99,9 s
- Aux Output: Nothing, 3, 4, 5, 6.
- Name: Up to 5 characters

External Failure 6

- Action: Nothing, Log, Alarm, Trip
- Trip Delay: 0 to 99,9 s
- Aux Output: Nothing, 3, 4, 5, 6.
- Name: Up to 5 characters

External Failure 7

- Action: Nothing, Log, Alarm, Trip
- Trip Delay: 0 to 99,9 s
- Aux Output: Nothing, 3, 4, 5, 6.
- Name: Up to 5 characters

External Failure 8

- Action: Nothing, Log, Alarm, Trip
- Trip Delay: 0 to 99,9 s
- Aux Output: Nothing, 3, 4, 5, 6.
- Name: Up to 5 characters

PARAMETERIZATION BY COMPUTER



ZYGGOT SUPERGER

Zyggot SuperGer is a configuration software and supervisor for the whole Zyggot family. Currently, the software performs the relays parameterization of the Zyggot Temperature system. In future versions, it will also perform the programming of the system temperature sensors and perform the configuration for the Zyggot Arc system.

The software is available on CD with the relay or through Varixx's website (<http://www.varixx.com.br>), the main screen program is showed next.

Although you can perform the parameterization of the relay directly on the same, using software has advantages such as storing relay's settings in a file on your computer and load predefined settings, reducing the time of parameterization.

The first step at the software is to choose on the system setup screen, the language and the work mode: currently is only available the Configurator mode.

Once chosen the Configurator mode, choose the relay of Zyggot Tubular / BT system.

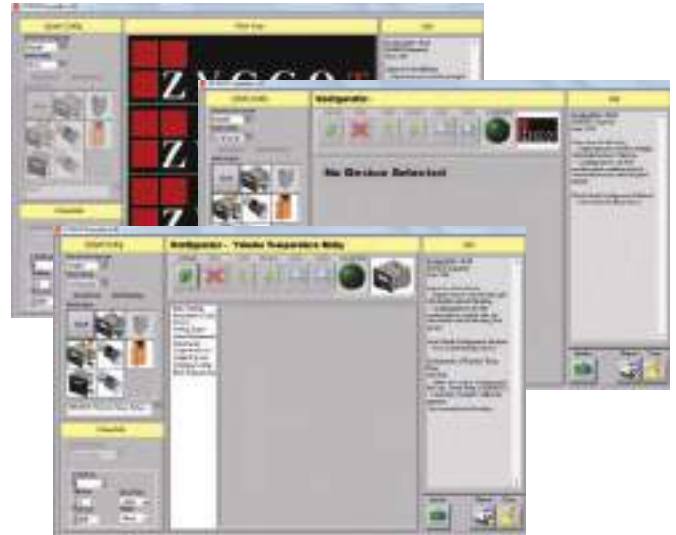

The next step is to accomplish the connection with the relay. Therefore, adjust the values of the Modbus communication in the relay and activate the same in the mode RS-232. For details about how to activate the Modbus, see the section of the programming menu. Use an RS-232 / RJ45 cable to make the connection between the relay and a computer. In the Zyggot SuperGer program, fill in the connection tab the serial port information to use and the Modbus information as the relay address, Baud Rate, parity and timeout. At the end, press the Connect button.

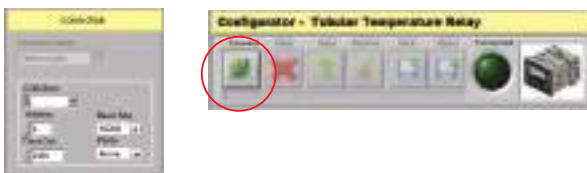

When the connection occurs, the connected lamp lights. If the initial reading box is marked, after the connection with the relay, all relay parameters will be transferred to the program. At the end, a success message appears.

Use the buttons of save and open to save a relay information in a file on your computer and download the same information in other relays.



To ensure that data are transmitted to the relay, is necessary to press the send button.

The button Receive forces a reading of all the relay data.

The program records in history log all activities that occurred.

The new update button allows you to always have the latest software version with just one mouse click.



CONFIGURATION OF THE SENSOR



ZYGGOT SOFTWARE MANAGER

Zyggot Manager is a configurator software that performs the addressing and the sensors test. The software is available on the CD that accompanies the relay or through Varixx's website (<http://www.varixx.com.br>). The following image shows the main screen of the software.

The program allows checking and defining important parameters before the use of the sensor network. Through it, the address of the sensor and other network parameters, the target emissivity considered by the sensor and habilitation of the terminating resistor are set up.

Note: When using unidex tape (emissivity known and constant over the years) must use the emissivity value 0,95.

The friendly interface allows the target temperature view and the sensor's case in many ways:

- Through a graph you can check the temperature measured in time. The end of scale can be changed with a click of the mouse.
- The temperature readings are also indicated in numerical order.
- Through a marker "analog". The full-scale value can be changed.

You can also send a command to the sensor's LED flashes, in the same manner as is done in the relay for identification of the sensors network.

Main screen of the software manager

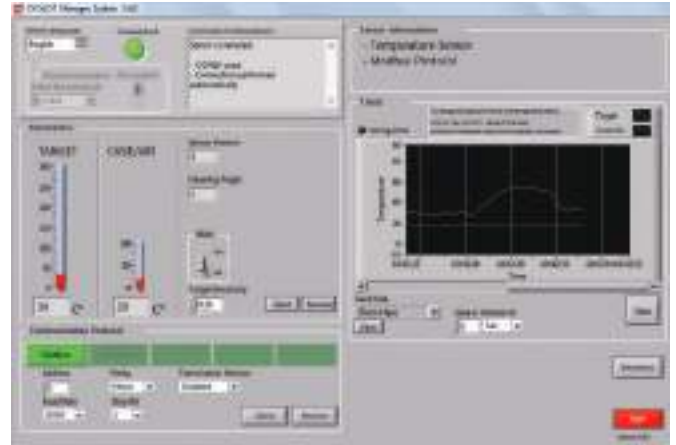

⚠ CAUTION



- Do not connect the sensor to the PC while the other mini USB port is connected on the network.



- NEVER connect two sensors simultaneously to the PC.



- ALWAYS address one sensor at a time.

CONFIGURATION OF THE SENSOR

ADDRESSING OF THE SENSORS

For do not have commitment of the proper functioning of the system, it is essential that you follow all the configuration instructions of the sensors, given below.

You must run the configuration of each sensor before installing them mechanically.

A) Install Zyggot Manager on your computer and run it in sequence;

B) Connect the configurator cable (supplied with the Zyggot Temperature Installation and Maintenance Briefcase) to a PC's USB port and to one of the mini USB port of the sensor.

C) The program automatically detects the door referring to the sensor. If you want, you can also manually select the sensor port. Therefore, mark the box Manual Connection, select the COM port referring to the sensor and press Connect. If there is no sensor connected to the selected port, an error message will appear.

Main screen of the software manager

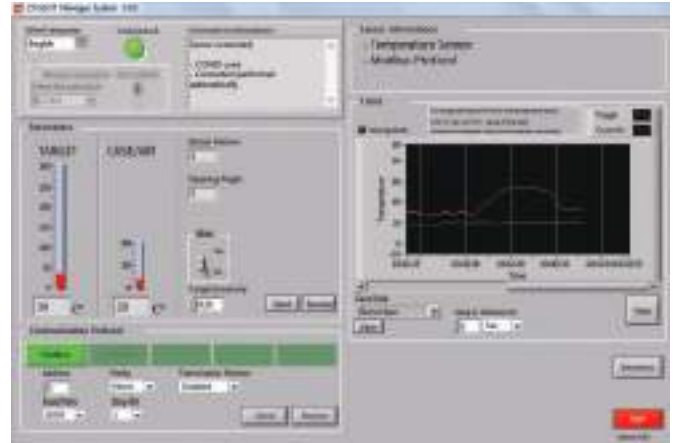

D) When connecting the sensor, the program will recognize it and will automatically indicate the type of communication protocol with the sensor (Modbus, CanOpen) and will indicate by a green button that the same is connected.

E) Set the sensor address (1 to 125) and choose if the terminating resistor will be activated or not. Other parameters of the serial communication are also available for configuration. By default, all sensors leave the factory with address 1 and network parameters for communication with Zyggot Temperature Relay. At the end, press the Send button.

Obs.: Each sensor must have a unique network address (from 1 to 125). When more than one sensor has the same network address, occur conflicts and the system non-operation.

Note: The wired sensor networks shall have two terminating resistors: one on the first sensor network and another on the last. You can use an external resistor or internally activate the sensors terminating resistor during the configuration. If other resistors are added to the network, it may cause unstable network and non-functioning. Varixx provides physical termination resistors for use in their sensor networks.

F) Insert the target emissivity and press the Send button.

Note: When using Unidex tape (emissivity known and constant over the years) must use the value of emissivity 0,95 (default).

G) Write the address of the sensor, to have a map of the location of the panel or the installation site. This is the address that will be shown on the relay display referring to this sensor, for its correct identification.

SUPERVISORY SOFTWARE



SUPERVISORY ZYGGOT

Zyggot Supervisory is a monitoring software that performs communication with the relay and presents sensor readings on the computer screen like a supervisory system. The software is available on the CD that accompanies the relay or through Varixx's website (<http://www.varixx.com.br>). The figure below shows a few screens of the program.

In the program you can view and adjust alarm levels and trip of each sensor. Visualize the temperature of all sensors and verify the individual state of each sensor.

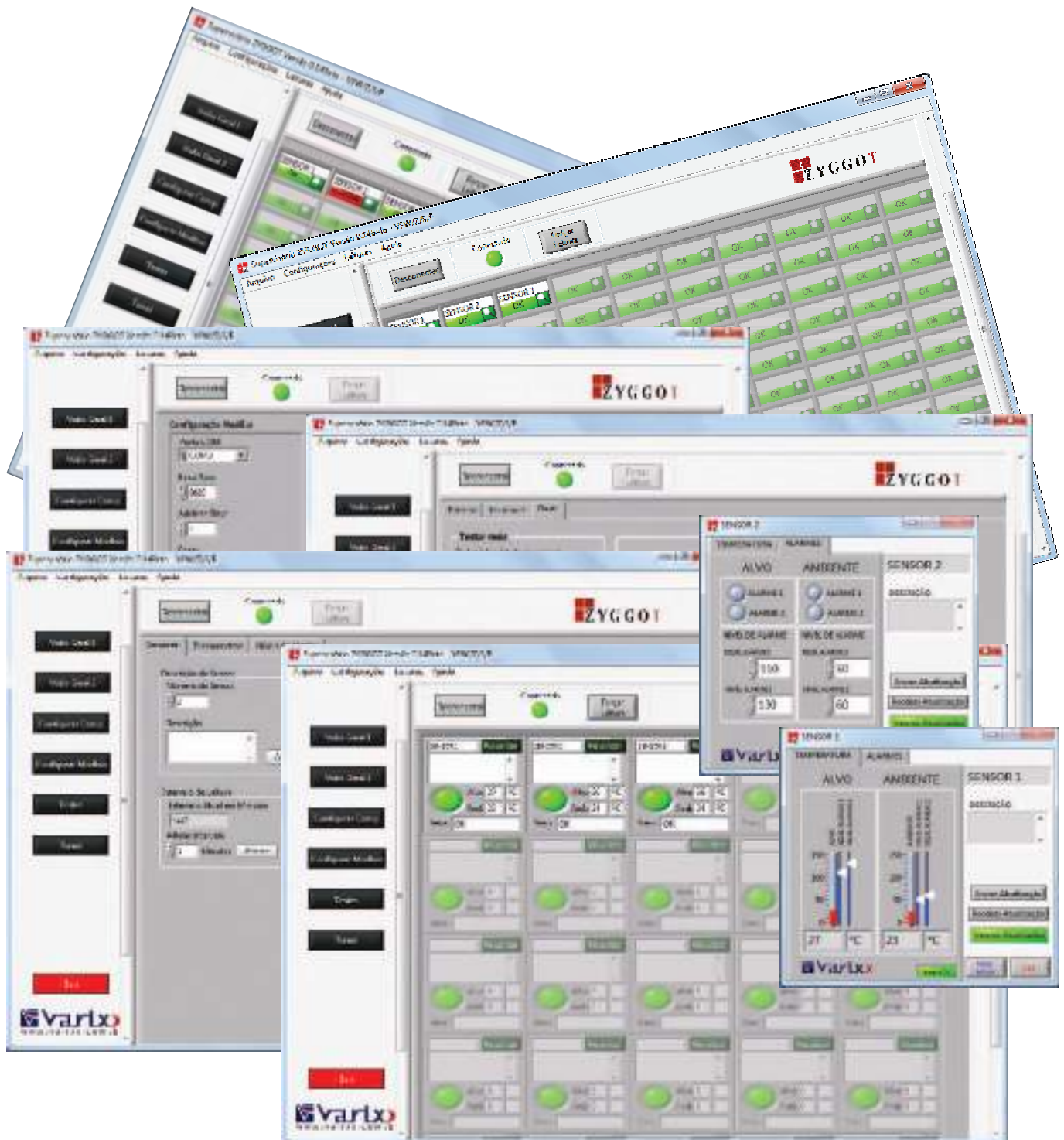



VERIFICATION OF ALARM AND HISTORY OF FAILURE

The F1 and F2 keys (VZX model) or K0 pressed for the third time (VZT model) brings on the alarm screens and failure history log. In any of the screens you can use the navigation keys to verify the active alarms, events/recorded history, information about the relay version and total operating time, information about the plant, panel and installation date besides verify date and time of the real time clock.

Being in the Alarm screen, indicated by an alarm clock and black background, press ENTER to see details occurred in each alarm, and then press any of the arrow keys shown above to appear a menu with the following possibilities: Ack and Ack All to recognize one or all alarms and Clr and Clr All to clean one or all alarms besides Esc to exit the submenu options. Being in the history screen can be observed up to 125 memories of events that occurred, including failure recognition. In this menu you can not clean the items. The cleaning of the history is done through the programming menu.



VERIFICATION OF READINGS AND GENERAL DATA

The K1 key on VZX model or K0 in VZT model, calls the main screen 1. Using the navigation keys, you can scroll through 13 screens of this group.

At the bottom of each screen, we have the following information, given in the form of signal lamps (active when white and inactive when black):

- FA: Active Failure.
- AIR: Overtemperature at the case sensor/Air.
- TA: Overtemperature at the Target.
- NR: Sensor not responding.
- AL: Acted Alarm (alarm relay)
- TR: Acted Trip (trip relay).

The Screen 1 shows the biggest target temperature and the biggest sensor case temperature (Air), besides the number of sensors responding and not responding.

The Screen 2 shows if a reading is being held and the sensor's number that the relay is reading.

The Screen 3 shows the number of programmed sensors and the number of responding sensors (OK).

The Screen 4 shows the total number of alarms and total number of trips that occurred. This information can be restarted in the programming menu.

The Screen 5 shows indications (via lamps) of communication error, sensor not responding, failure by differential temperature, alarm and active trip. It also indicates if all sensors are operating correctly.

The Screen 6 shows conditions of the Modbus communication. It indicates if the Modbus is activated, if there is error or is functioning properly. In a box, also indicates the message status valid or error.

The Screen 7 shows the states of the 12 digital inputs.

The Screen 8 shows the states of the six digital outputs.

The Screen 9 shows if was reached some temperature level of Alarm or Trip. In the screen is presented independently the indications of alarm point, trip point, air alarm and air trip, besides indicating occurrence of trip by differential elevation of targets temperature.

The Screen 10 presents actuation of alarm/-trip per group. The indications are separated by group and if the performance occurred due to temperature limit of point or air.

The Screen 11 presents detailed information about the communication on sensor's network.

The Screen 12 presents information about the Profibus communication, presenting the relay address on the network and the message status in binary code.

The Screen 13 presents the percentages values of the 04 analog inputs.

Status Register, Low-Byte	
bit 7-6	WD_State 1.0: State of the Watchdog State Machine 00 = BAUD_SEARCH state 01 = BAUD_CONTROL state 10 = DP_CONTROL state 11 = Not possible
bit 5-4	DP_State 1.0: State of the DP State Machine 00 = WAIT-PRM state 01 = WAIT-CFG state 10 = DATA-EXCH state 11 = Not possible
bit 3	Reserved
bit 2	Diag_Flag: Status of the Diagnosis-Buffer 0 = The Diagnosis-Buffer had been fetched by the DP-Master 1 = The Diagnosis-Buffer had not been fetched by the DP-Master yet.
bit 1	Reserved
bit 0	Offline/Passive_Idle: Offline/Passive_Idle state 0 = VPC3+ is in Offline 1 = VPC3+ is in Passive_Idle.

Status Register, High-Byte	
bit 15-12	VPC3+Release 1.0: Release number for VPC3+ 0000 = Step A 1011 = Step B 1100 = Step C 1101 = Step D (this chip release) Rest = Not possible
bit 11-8	Baud Rate 1.0: The baud rate based by VPC3+ 0000 = 12.00 Mbps 0001 = 5.00 Mbps 0010 = 3.00 Mbps 0011 = 1.50 Mbps 0100 = 800.00 Kbits 0101 = 167.50 Kbits 0110 = 83.75 Kbits 0111 = 41.87 Kbits 1000 = 19.20 Kbits 1001 = 9.60 Kbits 1111 = after reset and during baud rate search Rest = not possible



VERIFICATION OF READINGS OF TARGET AND CASE (AIR) TEMPERATURE OF ALL SENSORS.

The K3 key (VZX model) or K1 (VZT model) calls the reading screens of all the target temperatures and case of the sensors.

VZX Model: The first time that the K3 key is pressed, there are the readings of the points. In the second time, the reading of the case (air) of the sensors. Use the navigation keys to visualize in 25 screens the temperature of the 125 sensors.

VZT Model: The third time the K1 key is pressed, there are the readings of the points. In the fourth time, the reading of the case (air) of the sensors. Use the navigation keys to visualize in 25 screens the temperature of the 125 sensors.

If the measured temperature exceeds the programmed alarm level, the corresponding index (A001 to A125 / T001 to T125) will flash and if the measured temperature exceeds the programmed trip level, the indication of temperature and also the index will flash.



VERIFICATION OF READINGS OF TARGET AND CASES (AIR) SELECTED

Besides the case temperature visualization and target of all sensors, it can be programmed 20 targets and 20 cases sensors (air) for quick viewing.

The K2 key (VZX model) or K1 (VZT model) brings on the verification screens of target readings and sensor case (air) selected.

In the first press of the button, it has the temperature screen of selected targets and by pressing a second time, it has the temperature screen of selected cases. On each screen, the temperatures of both sensors are displayed. Use the navigation keys to visualize in 10 screens the 20 set temperatures.

TO PROGRAM

VZX Model:

Select one of the two fields with the arrow keys up and down. The course selected is with a dotted line around, press Enter and insert the sensor number. It is not necessary to follow any numerical order.

VZT Model:

Click on the desired field and insert (via touch keyboard) the number of the desired sensor. If the measured temperature exceeds the set alarm level, the index will flash and if the measured temperature exceeds the trip level programmed, the indication of the temperature and also the index will flash.



VERIFICATION OF ALARM INDICATION AND TRIP OF TARGETS OF ALL SENSORS

The K4 key (VZX model) or K2 (VZT model) provides access to the verification screen of all alarm indications and target trip of the sensors. Pressing once, it has access to alarm indication for the points. Pressing the key a second time, it has access to trip indication for the points. Use the navigation keys to visualize in 25 screens the indication of all sensors.

The indication is the binary type (ON/OFF), of which an alarm or trip indication is signaled by a filled square. An empty square means that the alarm/trip has not occurred.



VERIFICATION OF ALARM INDICATION AND TRIP OF TARGETS OF ALL SENSORS

The K5 key (VZX model) or K2 (VZT model) allows access to the verification screen of all alarm indications and case trip/air of the sensors.

VZX Model:

Press the key once to visualize the alarm indication due to temperature limit on the sensor case (air). Press the button a second time to visualize trip indication due to temperature limit of the sensor case (air).

VZT Model:

Press the key three times to visualize the alarm indication due to temperature limit on the sensor case (air). Press the key a fourth time to visualize trip indications due to temperature limit of the sensor case (air).

The indication is the binary type (ON/OFF), of which an alarm or trip indication is signaled by a filled square. An empty square means that the alarm/trip has not occurred.

OPERATION



VERIFICATION OF INDICATION OF ACTIVE FAILURES

The K6 key (VZX model) or K0 (VZT model) provides access to verification screen of all indications of active failures.

VZX Model:

The first time the K6 key is pressed, it has indications of active failures. Use the navigation keys to visualize in 9 screens all active failures.

VZT Model:

The second time the K0 key is pressed, it has indications of active failures. Use the navigation keys to visualize in 9 screens all active failures.

Screen 1 presents active failures due to high temperatures indicated by the sensor network: the failures are separate targets alarms, trips targets, case alarms/air and case trips /air.

Screens 2 and 3 indicate failures due to activation of the digital inputs (external failures).

Screens 4 and 5 indicate failures on the analog inputs (4 to 20 mA). To program the alarm levels and trip of each analogue input, consult the programming menu.

Screen 6 presents communication failures with the sensor network, exceeded operating time and failure by differential temperature rise. The sensors failure not answering indicate that there was no response when the relay made a request to at least one of the sensors while a communication failure with the sensor indicates that there was an answer of the sensor, but the message format was unreadable.

Screens 7 and 8 present failures caused by high temperature on the sensors groups. The screen 7 presents only groups alarms while the screen 8 presents only trips.

Screen 9 presents communication failure in the Profibus network.



VERIFICATION OF GENERAL INFORMATION

The K6 key (VZX model) or K0 (VZT model) provides access to the verification screen of all indications of active failures. The second time the button is pressed, you have access to the menu with general information.

This menu is only for verification/reading, not allowing alteration of data.

On the menu are information about alarms/active failures, the communication state with sensor network, status of digital inputs and outputs, statistics with operation hours, quantity of alarms and trips and information about the software version, plant, location and mounting panel.



VERIFICATION OF INDICATION OF NOT RESPONDING SENSORS

The K8 key (VZX model) or K3 (VZT model) provides access to the sensor verification screen not responding.

VZX Model: The first time the K8 key is pressed, it has the sensors indications not responding. Use the navigation keys to visualize in 9 screens up to 125 sensors status.

VZT Model: The second time the K3 key is pressed, it has the sensors indications not responding. Use the navigation keys to visualize in 9 screens up to 125 sensors status.

The indications are binary type and one sensor not responding is represented by a black square and a sensor responding is represented by a white square in front of the sensor number.



FLASHING COMMAND (FLASH) TO EACH ONE OR ALL SENSORS

The K9 key (VZX model) or K4 (VZT model) provides access to the flashing command (flash). This action is useful to check the correct addressing of each sensor after installation or to detect points of failure in the sensors network. Press the key once to access the screen.

Each sensor has a high intensity LED on its back. When sending the flashing command, the LED flashes until the stop is required or until timed out (5 minutes). To command the flashing, enter the sensor address in the specific field and press ON. To stop, press OFF. To command the simultaneous flashing of all sensors, use the address 0 as sensor number.

Only VZX model:

The F1 and F2 keys in this menu have respectively the action of ON and OFF.

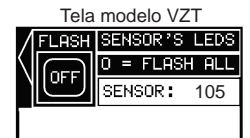
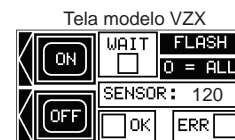



VERIFICATION OF CURVES (TRENDINGS) AND INDICATIONS OF FAILURE AND DATA OF DIFFERENTIAL TEMPERATURE

The K7 key (VZX model) or K3 (VZT model) provides access to the verification screen of all indications of active failures. The first time the key is pressed, you have access to the screen temperature curves (trending). Use the navigation keys to visualize in 12 screens all temperature curves.

The screen 1 presents the temperature curve of all measuring points. The sample rate is 50 ms, giving a total of 6,25 s per division. The ordinate scale is set in the main menu.

The screen 2 is identical to the first, but with the case/air temperature of the sensors.

On the screens 3 to 12 three curves are shown (full, dotted and dashed) . Each curve is related to a target temperature of a sensor or an analog input. The sensors selected for each curve stay indicated at the top of the screen.

The targets can be chosen on the main menu or directly on each screen, depending on the chosen differential mode (for details, see the programming menu section). For sensors, use the sensor address (1 to 125), for analog inputs, use the numbers 126 to 129, the numbers represent the entries in ascending order (1 to 4).The value 0 disables the curve.

If the mode of choice of the targets is DISPLAY, you can choose three sensors for each one of the screens of temperature curves. If the mode of choice of the targets is MENU, you can choose 6 monitoring sensors, being 3 sensors for the screens from 3 to 7 e the other 3 for the screens from 8 to 12. The sampling times for each screen and the total time for filling the same are presented in the following table.

The screens from 8 to 12 have the same sampling times of the screens 3 to 7.

There are two main ways to work with the screens: 2 groups of 5 screens, repeating the sampling times, you can select 6 different sensors (3 per group) with possibility to visualize multiple curves (screen cycle times from 144 s to 144 h); using all the different indexes (since the selection mode is DISPLAY), can be visualized curves of up to 30 sensors/analog inputs.

All curves use the same scale on the ordinate axis. The temperature value limit is set via the main menu.



INDICATIONS OF FAILURE AND DATA OF DIFFERENTIAL TEMPERATURE

The K7 key (VZX model) or K3 (VZT model) provides access to the verification screens of all indications of differential temperature rise.

VZX Model:

The second time the K7 key is pressed it has access to the percentage values of temperature rise. Use the navigation keys to visualize in 25 screens the percentage increase of all sensors.

Screen	Sampling time	Screen Cycle
3 and 8	1 s	144 s
4 and 9	10 s	1440 s
5 and 10	1 m	144 m
6 and 11	10 m	1440 m
7 and 12	1 h	114 h

The third time the button is pressed, is visualized the read values used as basis for calculating the temperature differential value. Use the navigation keys to visualize in 25 screens the temperature value used as the basis for the differential calculation of each sensor.

VZT Model:

The third time the key is pressed K3, it has access to the percentage values of temperature rise and the values used as the basis for calculating the differential value. Use the navigation keys to visualize in 25 screens the percentage values of temperature rise of sensors and in other 25 screens the values basis to calculate the percentage. A screen with the percentage of the analog inputs is also presented.

The measuring period is defined in the main menu, as well as the allowed elevation. In case of activation of the alarm or failure of differential point, the indication of elevation percentage and the indication of last reading will flash to the point with problem.

This type of protection can be more sensitive than the protection of absolute level, detecting elevation tendencies at certain points. Usually, it is only programmed for alarm and, in case of an occurrence, a stop is scheduled for more detailed verification of the occurrence.

Example:

A period of 1 month (720 hours) is defined and an elevation of 20% is allowed Every 720 hours, the measured temperature is memorized and turns up the new reference for the new period of 720 hours. If there is an elevation of more than 20%, the failure is activated and actuated the corresponding auxiliary relay.

HOW TO



HOW TO PROGRAM THE RELAY

There are two ways: by IHM or through the setup program.

- To program via the PC software, see the section "Parameterization by Computer".
- To program directly in the IHM, see the section "Parameterization by Relay".

HOW TO VERIFY NOT RESPONDING SENSORS.

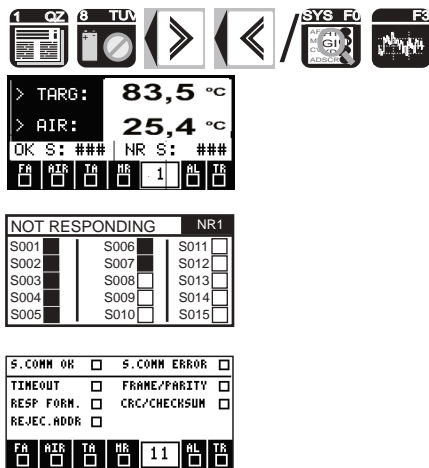

Above are represented the main keys and screens involved.

To view the map of not responding sensors, hit K8 (VZX) or K3 (VZT) to bring on the not responding sensors screen. The sensors not responding will be with the square in black.

If during an attempt of reading does not occur the response, beyond the indication on the screen of the not responding sensors, it will also be presented on the main screen the amount of not responding sensors.

Not responding sensors receive as temperature reading the value 8888 (invalid). In this case, there will be no trip or alarm by temperature, but Not responding, instead.

HOW TO CHOOSE THE LANGUAGE.

For the screens and menus in the relay 3 languages: are available English, Portuguese and Spanish. A fourth language can be requested when purchasing (Custom) by prior agreement with the manufacturer.

To select the language:

- Enter the "Menu, Submenu Config Rele",
- Select the item "Language",
- Press Enter,
- Select the required language by pressing Enter again to confirm and ESC to exit the menu.

HOW TO SET THE REAL-TIME CLOCK.

If necessary, due to daylight saving time or other reasons proceed as follows:

- Enter Menu, Submenu Relay Config,
- Select the item Set Clock,
- Press Enter, Insert the new data using the small arrows in the display, press Enter to confirm and ESC to exit the menu.

HOW TO NOMINATE THE PLANT, PLACE AND PANEL, AND ENTER WITH THE OPERATION START DATE.

For informational purposes, you can nominate the items above with up to 5 characters and enter the operation start date.

- Enter Menu, Submenu Relay Config,
- Select the desired item,
- Press Enter, Insert the new data using the number keys, and in the case of start date, using the small arrows in the display, press Enter to confirm and ESC to exit the menu.

HOW TO SET THE PARAMETERS (PARAMETERS MENU).

- Enter the Main Menu and then the submenu Param. Config.
- Select the item to change and press ENTER.
- Choose the option on the list of each parameter or insert the data if it is numeric.
- Press ENTER to confirm.
- Choose the next item and repeat.

HOW TO SET THE SENSORS (SENSOR MENU).

- Enter the Main Menu and then the submenu Sensors.
- Select the item to change and press ENTER.
- Choose the option on the list of each parameter or insert the data if it is numeric,
- Press ENTER to confirm.
- Choose the next item and repeat.

HOW TO SET THE ANALOG INPUTS. (ANALOG INPUT MENU)

For the analog inputs, you can enter the name of each on (5 characters), facilitating the identification, choose the read mode and scale.

- Enter the Main Menu and then the submenu Analog Input.
- Select the item to change and press ENTER.
- Choose the option on the list of each parameter or insert the data if it is numeric or alphanumeric.
- Press ENTER to confirm.
- Choose the next item and repeat.

HOW TO SET THE MODBUS COMMUNICATION. (MODBUS MENU).

For this menu, the names are the classics and there is nothing to explain, since the user must know the protocol for using the Modbus communication. The port for Modbus communication is the MJ1.

- Enter the Main Menu and then the Modbus submenu.
- Select the item to change and press ENTER,
- Choose the option on the list of each parameter or insert the data if it is numeric.
- Press ENTER to confirm,
- Choose the next item and repeat.

HOW TO SET THE TRENDING CURVES. ("TRENDING CONFIG" MENU).

The curves for the temperature and analog inputs must be set in this menu.

- Enter the Main Menu and then the submenu Trending Config.
- Select the item to change and press ENTER,
- Choose the option on the list of each parameter or insert the data if it is numeric or alphanumeric.
- Press ENTER to confirm,
- Choose the next item and repeat.

HOW TO SET EVERY TARGET EMISSIVITY.

The emissivity indexes for each target can be set using the sensor programming software. By default, the sensor is set to emissivity 0,95. See "Sensor Configuration" section for details.

HOW TO SET THE ALARM LEVELS FOR TARGETS OF OVER TEMPERATURE.

Target alarm levels can be set in the programming by blocks or in the Levels Alarm Targets menu. You can program a single group with all sensors if the level is the same for all or up to 5 different levels, one for each block.

- Enter the Main Menu and then the submenu Levels Alarm Targets.
- It is presented a menu of 13 submenus, each one containing up to 10 levels.
- Select the level to be changed and enter the value.
- Press ENTER to confirm,
- Choose the next item and repeat.

HOW TO SET THE TRIP LEVELS FOR TARGETS OF OVER-TEMPERATURE.

Targets trip levels can be set in programming by blocks. You can program a single group with all sensors if the level is the same for all or up to 5 different levels, one for each block. Otherwise, even after making the programming by blocks and if you want to individually change any or all levels, is by the "Targets Trip Levels" menu.

- Enter the Main Menu and then the submenu Targets Trip Levels.
- It is presented a menu of 13 submenus, each containing up to 10 levels.
- Select the level to be changed and enter the value.
- Press ENTER to confirm,
- Choose the next item and repeat.

HOW TO SET ACTIONS FOR EACH PROTECTION. ("PROTECTIONS" MENU).

The action to be taken, which can be: Nothing (disables protection), Log (the event is inserted into the list of historical and alarms but no output relay is triggered (not even Alarm relay or Trip relay), Alarm (Alarm output relay is triggered) and Trip (relay outputs, Alarm and Trip are triggered).

There are 3 protections submenus: Protections 1/1, Protections 2/3 and Protections 3/3.

The first one contains general protections, the second one protections regarding the analog inputs and the third one protections regarding the digital inputs.

- Enter the Main Menu and then the submenu Protections.
- It is presented a menu with 3 submenus.
- Select one and press ENTER.
- Select the sub item of protection to be programmed and Press ENTER,
- Select the action and the auxiliary relay.

MODBUS RECORDS MAP ADDRESSES ONLY FOR READING



TYPES OF MODBUS DATA:

Type of Modbus Data	Size
Coil	1 bit
Holding Register	16 bits

OBS.: Entire double fields are consisted of two 16 bit records, wherein the first record is the least significant and the second record is the most significant (low order word first).

Example: If the relay is with 66000 (101D0 in hexadecimal) hours of use, the record 3925 will contain the value 01D0H, and the record 3926 will contain 0001H. As the record 3925 is the least significant one, you should read the final value as 000101D0H, which is equivalent to 66000 in decimal.

DATA READINGS

TYPE OF MODBUS DATA:
HOLDING RECORD
DEFAULT OFFSET = 3000

001 to 125: Targets Temp. 1 to 125.
126 to 250: Cases/Air Temp. 1 to 125.

901 to 904: Analog 1 to 4 (%)
905 to 908: Analog 1 to 5 (°C or °F)
916: Higher value of Target.
917: Higher value of Air.
919: Number of Responding Sensors.
921: Total number of alarms.
923: Total number of trips.
976: Modbus Table Message.
1066: Total Number of Sensors.
1335: Number of Responding Sensors.
1336: Number of Not Responding Sensors.
3051: Analog 1 (% or °C or °F).
3052: Analog 2 (% or °C or °F).
3053: Analog 3 (% or °C or °F).
3054: Analog 4 (% or °C or °F).

MODBUS FUNCTIONS:

Type of Modbus Data	Function	Code
Coil	Reading	0x01
	Writing	0x05
Holding Register	Reading	0x03
	Writing	0x06

READING OF FLAGS OF STATE

TYPE OF MODBUS DATA:
COIL
DEFAULT OFFSET = 3000

004: Track Temperatures body OK
017: Deleted Statistical Data.
042: Actuated Alarm Relay.
043: Actuated Trip Relay.
047: Active Failure.
049: Valid Differential.
052: Failure Differential.
055: TX/RX Sensors Number Timeout.
056: TX/RX Reading Temp. Timeout
057: Not Responding.
059: Failure related to Target.
060: Failure related to Air.
061: 0= Centigrade/ 1= Fahrenheit.
065: Target Alarm.
066: Target Trip.
067: Air Alarm.
068: Air Trip.
081 to 082: Digital Inputs 1 to 12.
121 to 126: Digital Outputs 1 to 6.
257: Sensors Not Responding.
259: Alarm related to Target.
260: Trip relating to Target.
261: Alarm related to Air.
262: Trip related to Air.
263: Failure related to Differential.
278: Analog Alarm 1.
279: Analog Trip 1.
280: Analog Alarm 2.
281: Analog Trip 2.
282: Analog Alarm 3.
283: Analog Trip 3.
284: Analog Alarm 4.
285: Analog Trip 4.
294: Excess of operating hours.
304 to 311: External Failures 1 to 8.
501 to 625: Sensors Not Responding from 1 to 125.

* READING OF FLAGS of STATE

TIPO DE DADO MTYPE OF MODBUS DATA:
HOLDING RECORD
ODBUS:

DEFAULT OFFSET = 10000

5001.2 to 5125.2: Alarm of sensors targets 1 to 125.
6001.2 to 6125.2: Trip of sensors targets 1 to 125.
7001.2 to 7125.2: Alarm of cases/Air sensors 1 to 125.
8001.2 to 8125.2: Trip of cases/Air sensors 1 to 125.

*Although using 16 data bits, each bit represents a variable. Thus, the address 15001.2 is related to the second bit (from right to left) of the record 15001. The value 0 in the bit indicates that the record is OFF and the value 1 indicates that the record is ON.

DATA READINGS

(ENTIRE DOUBLE, 32 BITS)
*LOW ORDER WORD FIRST

TYPE OF MODBUS DATA:
HOLDING RECORDt
DEFAULT OFFSET = 3000

925..26: Total Hours Operating.
946..47: Software Version.

MODBUS RECORDS MAP

ADDRESSES ONLY FOR READING



PARAMETERS

TYPE OF MODBUS DATA:
HOLDING RECORD
DEFAULT OFFSET = 3000

1020 to 1029: Plant Identification.
1030 to 1039: Local Identification.
1040 to 1049: Date of Installation.
1050 to 1059: CCM Identification.
1060: Sensors number.
1063: Sensor number to Flash (0= all).
1064: Air alarm level.
1065: Air trip level.
501 to 625: Targets alarm level 1 to 125.
626 to 750: Targets trip level 1 to 125.
1190: Analog Reading Mode (0=% 1= Temper.).
1191: Analog Scale Reading (10 to 9999).
1231/1232/1233: Plot. 1, curves 1, 2 and 3 (0 to 125).
1234/1235/1236: Plot. 2 (idem).
1237/1238/1239: Plot. 3 (idem).
1240/1241/1242: Plot. 4 (idem).
1243/1244/1245: Plot. 5 (idem).
1246/1247/1248: Plot. 6 (idem).
1249/1250/1251: Plot. 7 (idem).
1252/1253/1254: Plot. 8 (idem).
1255/1256/1257: Plot. 9 (idem).
1258/1259/1260: Plot. 10 (idem).
1273: Scale Graphics (0 to 5000°)
1274: Graphics Scale Mode (Trend Index Mode) (0= Display, 1= Menu).
1275: Reset Graphics (0= No, 1= Enable).
1283: Reset in failures (0= No, 1= Yes).
1285: Calls Alarm Screen in Trip (0= No, 1= Yes).
1286: Calls Alarm Screen in Alarm (0= No, 1= Yes).
1287: Returns to screen 1 Auto (0 to 999 / 0= No).
1371: Language (0= English, 1= Portuguese, 2= Spanish, 3 =Custom).

PARAMETERS OF PROTECTION

TYPE OF MODBUS DATA:
HOLDING RECORD
DEFAULT OFFSET = 3000

Values for Actions: 0= None, 1= Log, 2= Alarm, 4= Trip.
Failures named as "Alarm" do not have the option "Trip", and failures named as "Trip" do not have the option "Alarm".

Values for auxiliary output relay (Aux Output): 0- None, 1=Aux3, 2=Aux4, 4=Aux5, 8=Aux6.

1632: Action for "Sensor Not Responding".
1633: Aux for "Sensor Not Responding".
1634: Action for Target Alarm.
1635: Aux for Target Alarm.
1636: Action for Air Alarm.
1637: Aux for Air Alarm.
1638: Action for Target Trip.
1639: Aux for Target Trip.
1640: Action for Air Trip.
1641: Aux for Target Trip.
1642: Action for "Differential".
1643: % Level for "Differential" (0-200%).
1644: "Differential" Period (0-10000 h).
1645: "Warm Up" Period for "Differential" (0-100 hours).
1646: Aux for "Differential".
1651: Action Analog Signal Alarm 1.
1652: Level Analog Signal Alarm 1(0-100%).
1656: Aux for Analog Signal Alarm 1.
1657: Action for Analog Signal Trip 1.
1658: Level Analog Signal Trip 1 (0-100%).
1663: Aux for Analog Signal Trip 1.
1664: Action for Analog Signal Alarm 2.
1665: Level Analog Signal Alarm 2 (0-100%).
1669: Aux for Analog Signal Alarm 2.
1670: Action for Analog Signal Trip 2.
1671: Level Analog Signal Trip 2 (0-100%).
1676: Aux for Analog Signal Trip 2.
1677: Action for Analog Signal Alarm 3.
1678: Level Analog Signal Alarm 3 (0-100%).
1682: Aux for Analog Signal Alarm 3.
1683: Action for Analog Signal Trip 3.
1684: Level Analog Signal Trip 3 (0-100%).
1689: Aux for Analog Signal Trip 3.
1690: Action for Analog Signal Alarm 4.

1691: Level Analog Signal Alarm 4 (0-100%).
1695: Aux for Analog Signal Alarm 4.
1696: Action for Analog Signal Trip 4.
1697: Level Analog Signal Trip 4 (0-100%).
1702: Aux for Analog Signal Trip 4.
1755: Action for "Operating Hours".
1756: Level for "Operating Hours" (0-30000 x 1000).
1757: Aux for "Operating Hours".
1797: Action for "External Failure 1".
1798: Retardation for "External Failure 1" (0-999 x 0.1 s).
1800: Aux for "External Failure 1".
1801: Action for "External Failure 2".
1802: Retardation for "External Failure 2" (0-999 x 0.1 s).
1804: Aux for "External Failure 2".
1805: Action for "External Failure 3".
1806: Retardation for "External Failure 3" (0-999 x 0.1 s).
1808: Aux for "External Failure 3".
1809: Action for "External Failure 4".
1810: Retardation for "External Failure 4" (0-999 x 0.1 s).
1812: Aux for "External Failure 4".
1813: Action for "External Failure 5".
1814: Retardation for "External Failure 5" (0-999 x 0.1 s).
1816: Aux for "External Failure 5".
1817: Action for "External Failure 6".
1818: Retardation for "External Failure 6" (0-999 x 0.1 s).
1820: Aux for "External Failure 6".
1821: Action for "External Failure 7".
1822: Retardation for "External Failure 7" (0-999 x 0.1 s).
1824: Aux for "External Failure 7".
1825: Action for "External Failure 8".
1826: Retardation for "External Failure 8" (0-999 x 0.1 s).
1828: Aux for "External Failure 8".
1850 to 1854: Name "External Failure 1".
1855 to 1859: Name "External Failure 2".
1860 to 1864: Name "External Failure 3".
1865 to 1869: Name "External Failure 4".
1870 to 1874: Name "External Failure 5".
1875 to 1879: Name "External Failure 6".
1880 to 1885: Name "External Failure 7".
1886 to 1889: Name "External Failure 8".

PROFIBUS RECORDS MAP WRITING AND READING



PROFIBUS - WRITE REGISTER		
WORD 1 – RESERVED	WORD 1	INTEGER
WORD 2 – BIT 1 – MUTE	WORD 2	BIT 1
WORD 2 – BIT 2 – RESET	WORD 2	BIT 2
WORD 2 – BIT 3 – RESERVED	WORD 2	BIT 3
WORD 2 – BIT 4 – RESERVED	WORD 2	BIT 4
WORD 2 – BIT 5 – RESERVED	WORD 2	BIT 5
WORD 2 – BIT 6 – RESERVED	WORD 2	BIT 6
WORD 2 – BIT 7 – RESERVED	WORD 2	BIT 7
WORD 2 – BIT 8 – RESERVED	WORD 2	BIT 8
WORD 2 – BIT 9 – RESERVED	WORD 2	BIT 9
WORD 2 – BIT 10 – RESERVED	WORD 2	BIT 10
WORD 2 – BIT 11 – RESERVED	WORD 2	BIT 11
WORD 2 – BIT 12 – RESERVED	WORD 2	BIT 12
WORD 2 – BIT 13 – RESERVED	WORD 2	BIT 13
WORD 2 – BIT 14 – RESERVED	WORD 2	BIT 14
WORD 2 – BIT 15 – RESERVED	WORD 2	BIT 15
WORD 2 – BIT 16 – RESERVED	WORD 2	BIT 16
WORD 3 – SENSOR REQUEST	WORD 3	INTEGER = 1 to 125

PROFIBUS - READ REGISTER		
RESERVED	WORD 1	
STATUS WORD 1	WORD 2	16 BITS
STATUS WORD 2	WORD 3	16 BITS
STATUS WORD 3	WORD 4	16 BITS
STATUS WORD 4	WORD 5	16 BITS
STATUS WORD 5	WORD 6	16 BITS
STATUS WORD 6	WORD 7	16 BITS
STATUS WORD 7	WORD 8	16 BITS
STATUS WORD 8	WORD 9	16 BITS
STATUS WORD 9	WORD 10	16 BITS
STATUS WORD 10	WORD 11	16 BITS
ANALOG INPUT 1	WORD 12	INTEGER
ANALOG INPUT 2	WORD 13	INTEGER
ANALOG INPUT 3	WORD 14	INTEGER
ANALOG INPUT 4	WORD 15	INTEGER
RESERVED	WORD 16	INTEGER
MAXIMUM TARGET TEMPERATURE	WORD 17	INTEGER
MAXIMUM AIR TEMPERATURE	WORD 18	INTEGER
TOTAL SENSORS RESPONDING	WORD 19	INTEGER
TOTAL SENSORS NOT RESPONDING	WORD 20	INTEGER
TOTAL ALARMS	WORD 21	INTEGER
TOTAL TRIPS	WORD 22	INTEGER
SENSOR NUMBER BROADCAST (1-125)	WORD 23	INTEGER
TARGET TEMPERATURE BROADCAST	WORD 24	INTEGER
AIR TEMPERATURE BROADCAST	WORD 25	INTEGER
SENSOR NUMBER REQUEST (1 – 125)	WORD 26	INTEGER
TARGET TEMPERATURE REQUESTED	WORD 27	INTEGER
AIR TEMPERATURE REQUESTED	WORD 28	INTEGER
RESERVED	WORD 29	INTEGER
RESERVED	WORD 30	INTEGER

USING PROFIBUS-DP COMMUNICATION

WRITING:

2 "Words" are used for writing. In the "Word" 2, the bits can be set according to the table, to generate "Mute" remote (alarm silencing) or "Reset" remote. The other bits are reserved. In the "Word" 3, you should write the number of the sensor to be read (Sensor Request): from 1 to 125.

READING:

Readings are performed continuously. In all, there are 30 Words of reading. The records are divided into records of status and values:

- There are 10 status records, each one with 16 bits. Each bit of the status record indicates a condition. Details about the status records are presented on the following pages.

- There are 12 records of integer values, each one of 16 bits, which indicate temperature values, number of sensors not responding, total alarms, total trips, etc. The record values can range from 0 to 32000.

EXAMPLE:

You want to read if there is active trip the relay. The active trip status is indicated in the Status Word 1, bit 11 (see next page). If this bit is in high level (1), the trip is active. A low level (0) indicates that the trip is not active.

PROFIBUS RECORDS MAP

DESCRIPTIONS OF THE RECORDS STATUS



STATUS WORD 1		
RESERVED	WORD 2	BIT 1
RESERVED	WORD 2	BIT 2
RESERVED	WORD 2	BIT 3
RESERVED	WORD 2	BIT 4
RESERVED	WORD 2	BIT 5
RESERVED	WORD 2	BIT 6
RESERVED	WORD 2	BIT 7
RESERVED	WORD 2	BIT 8
RESERVED	WORD 2	BIT 9
ALARM ON	WORD 2	BIT 10
TRIP ON	WORD 2	BIT 11
RESERVED	WORD 2	BIT 12
RESERVED	WORD 2	BIT 13
RESERVED	WORD 2	BIT 14
FAIL ACTIVE <F>	WORD 2	BIT 15
DIFERENCIAL PCT / DEGREE	WORD 2	BIT 16

STATUS WORD 3		
TARGET ALARM	WORD 4	BIT 1
TARGET TRIP	WORD 4	BIT 2
AIR ALARM	WORD 4	BIT 3
AIR TRIP	WORD 4	BIT 4
FLASH ON	WORD 4	BIT 5
FLASH OFF	WORD 4	BIT 6
RESERVED	WORD 4	BIT 7
RESERVED	WORD 4	BIT 8
RESERVED	WORD 4	BIT 9
RESERVED	WORD 4	BIT 10
RESERVED	WORD 4	BIT 11
RESERVED	WORD 4	BIT 12
RESERVED	WORD 4	BIT 13
RESERVED	WORD 4	BIT 14
RESERVED	WORD 4	BIT 15
RESERVED	WORD 4	BIT 16

STATUS WORD 5		
RESERVED	WORD 6	BIT 1
RESERVED	WORD 6	BIT 2
RESERVED	WORD 6	BIT 3
RESERVED	WORD 6	BIT 4
RESERVED	WORD 6	BIT 5
RESERVED	WORD 6	BIT 6
G1 TARGET TRIP	WORD 6	BIT 7
G1 AIR TRIP	WORD 6	BIT 8
G2 TARGET TRIP	WORD 6	BIT 9
G2 AIR TRIP	WORD 6	BIT 10
G3 TARGET TRIP	WORD 6	BIT 11
G3 AIR TRIP	WORD 6	BIT 12
G4 TARGET TRIP	WORD 6	BIT 13
G4 AIR TRIP	WORD 6	BIT 14
G4 TARGET TRIP	WORD 6	BIT 15
G4 AIR TRIP	WORD 6	BIT 16

STATUS WORD 2		
DIFERENCIAL FIRST / VALID	WORD 3	BIT 1
RESERVED	WORD 3	BIT 2
RESERVED	WORD 3	BIT 3
DIFFERENTIAL	WORD 3	BIT 4
RESERVED	WORD 3	BIT 5
RESERVED	WORD 3	BIT 6
RESERVED	WORD 3	BIT 7
RESERVED	WORD 3	BIT 8
NOT RESPONDING	WORD 3	BIT 9
RESERVED	WORD 3	BIT 10
TARGET FAIL	WORD 3	BIT 11
AIR FAIL	WORD 3	BIT 12
DEGREE (0) / FAHRENHEIT (1)	WORD 3	BIT 13
RESERVED	WORD 3	BIT 14
ALL SENSORS OK	WORD 3	BIT 15
RESERVED	WORD 3	BIT 16

STATUS WORD 4		
RESERVED	WORD 5	BIT 1
RESERVED	WORD 5	BIT 2
RESERVED	WORD 5	BIT 3
RESERVED	WORD 5	BIT 4
RESERVED	WORD 5	BIT 5
RESERVED	WORD 5	BIT 6
RESERVED	WORD 5	BIT 7
RESERVED	WORD 5	BIT 8
DIGITAL OUTPUT 1	WORD 5	BIT 9
DIGITAL OUTPUT 2	WORD 5	BIT 10
DIGITAL OUTPUT 3	WORD 5	BIT 11
DIGITAL OUTPUT 4	WORD 5	BIT 12
DIGITAL OUTPUT 5	WORD 5	BIT 13
DIGITAL OUTPUT 6	WORD 5	BIT 14
RESERVED	WORD 5	BIT 15
RESERVED	WORD 5	BIT 16

STATUS WORD 6		
RESERVED	WORD 7	BIT 1
RESERVED	WORD 7	BIT 2
RESERVED	WORD 7	BIT 3
RESERVED	WORD 7	BIT 4
RESERVED	WORD 7	BIT 5
RESERVED	WORD 7	BIT 6
RESERVED	WORD 7	BIT 7
RESERVED	WORD 7	BIT 8
RESERVED	WORD 7	BIT 9
CAN FAIL	WORD 7	BIT 10
PROFIBUS FAIL	WORD 7	BIT 11
RESERVED	WORD 7	BIT 12
RESERVED	WORD 7	BIT 13
RESERVED	WORD 7	BIT 14
RESERVED	WORD 7	BIT 15
RESERVED	WORD 7	BIT 16

PROFIBUS RECORDS MAP

DESCRIPTIONS OF THE RECORDS STATUS



STATUS WORD 7		
SENSOR_NOT_RESPONDING	WORD 8	BIT 1
RESERVED	WORD 8	BIT 2
TARGET ALRM	WORD 8	BIT 3
TARGET TRIP	WORD 8	BIT 4
AIR ALRM	WORD 8	BIT 5
AIR TRIP	WORD 8	BIT 6
TARG_DIFF	WORD 8	BIT 7
RESERVED	WORD 8	BIT 8
RESERVED	WORD 8	BIT 9
RESERVED	WORD 8	BIT 10
RESERVED	WORD 8	BIT 11
RESERVED	WORD 8	BIT 12
RESERVED	WORD 8	BIT 13
RESERVED	WORD 8	BIT 14
RESERVED	WORD 8	BIT 15
RESERVED	WORD 8	BIT 16

STATUS WORD 9		
RESERVED	WORD 10	BIT 1
RESERVED	WORD 10	BIT 2
RESERVED	WORD 10	BIT 3
RESERVED	WORD 10	BIT 4
RESERVED	WORD 10	BIT 5
SYSTEM OPERATING HOURS	WORD 10	BIT 6
RESERVED	WORD 10	BIT 7
SENSOR COMM FAIL	WORD 10	BIT 8
RESERVED	WORD 10	BIT 9
RESERVED	WORD 10	BIT 10
RESERVED	WORD 10	BIT 11
RESERVED	WORD 10	BIT 12
RESERVED	WORD 10	BIT 13
RESERVED	WORD 10	BIT 14
RESERVED	WORD 10	BIT 15
A94 DIGITAL INPUT EXTERNAL FAIL 1	WORD 10	BIT 16

STATUS WORD 8		
RESERVED	WORD 9	BIT 1
RESERVED	WORD 9	BIT 2
RESERVED	WORD 9	BIT 3
RESERVED	WORD 9	BIT 4
RESERVED	WORD 9	BIT 5
ANALOG SIGNAL 1 ALARM	WORD 9	BIT 6
ANALOG SIGNAL 1 TRIP	WORD 9	BIT 7
ANALOG SIGNAL 2 ALARM	WORD 9	BIT 8
ANALOG SIGNAL 2 TRIP	WORD 9	BIT 9
ANALOG SIGNAL 3 ALARM	WORD 9	BIT 10
ANALOG SIGNAL 3 TRIP	WORD 9	BIT 11
ANALOG SIGNAL 4 ALARM	WORD 9	BIT 12
ANALOG SIGNAL 4 TRIP	WORD 9	BIT 13
RESERVED	WORD 9	BIT 14
RESERVED	WORD 9	BIT 15
RESERVED	WORD 9	BIT 16

STATUS WORD 10		
A94 DIGITAL INPUT EXTERNAL FAIL 2	WORD 11	BIT 1
A94 DIGITAL INPUT EXTERNAL FAIL 3	WORD 11	BIT 2
A94 DIGITAL INPUT EXTERNAL FAIL 4	WORD 11	BIT 3
A94 DIGITAL INPUT EXTERNAL FAIL 5	WORD 11	BIT 4
A94 DIGITAL INPUT EXTERNAL FAIL 6	WORD 11	BIT 5
A94 DIGITAL INPUT EXTERNAL FAIL 7	WORD 11	BIT 6
A94 DIGITAL INPUT EXTERNAL FAIL 8	WORD 11	BIT 7
RESERVED	WORD 11	BIT 8
RESERVED	WORD 11	BIT 9
RESERVED	WORD 11	BIT 10
RESERVED	WORD 11	BIT 11
RESERVED	WORD 11	BIT 12
RESERVED	WORD 11	BIT 13
RESERVED	WORD 11	BIT 14
RESERVED	WORD 11	BIT 15
RESERVED	WORD 11	BIT 16

MANUAL ZYGGOTTUBULAR SYSTEM

Manual_Zyggot_Temp_Tube_V6P



Rua Phelippe Zaidan Maluf, 450 Piracicaba-SP

Distrito Industrial Unileste CEP 13422.190

fone: (19) 3424-4000 (19) 3301-6900 / fax: (19)3424-4001

mais informações: info@varixx.com.br

conheça nosso site: www.varixx.com.br

dois anosdegarantia para toda linha

suporte técnico especializado emtodo o Brasil

Zyggot é Marca Registrada da Varixx.
Varixx e seu logo são marcas registradas.
Outras marcas são registradas por seus respectivos proprietários.